

EM euromotor®

CATÁLOGO DE TENSORES
PARA DISTRIBUCIÓN

CATALOGUE TENSIONERS
FOR DISTRIBUTION



VERSION PDF 2010



ISO 9001 - 2000



2010

EM euromotor®



LA HISTORIA DE ALYCO S.R.L.

ALYCO S.R.L., una empresa familiar emplazada al oeste de la Ciudad de Buenos Aires, comienza su actividad en 1996, y desde ese momento fue creciendo sostenidamente. En el año 1999 registra su marca **EM euromotor**, fabricando en un principio filtros para automotor. Hacia el año 2000, decide renovar la forma de comercialización de la empresa, adoptando la venta exclusiva a través de su red de distribuidores, la cual fue acrecentándose con el tiempo. Ya en el año 2001 toma la representación de la compañía **Fleenor GmbH** con sede en Düsseldorf (Alemania), e inicia la importación de las correas **FLENNOR**, contando hoy con un amplísimo stock de más de 1000 códigos diferentes de correas. Desde el año 2004 discontinúa su producción de filtros y comienza a fabricar y comercializar tensores para correas de distribución y Multi V, con la marca **EM Euromotor**. **ALYCO S.R.L.** cuenta en la actualidad con una de las líneas más completas del mercado en tensores, con más de 700 modelos diferentes para correas de distribución y de accesorios, abarcando desde los más complejos tensores automáticos e hidráulicos hasta las más simples poleas. En los tensores **EM Euromotor** se montan rodamientos de primera calidad certificada, lo que unido a la moderna maquinaria empleada para la fabricación y los estrictos controles de elaboración, garantizan óptimos resultados de confiabilidad. **ALYCO S.R.L.** en su departamento de diseño y desarrollo continúa incorporando permanentemente nuevos modelos e introduciendo innovaciones acordes

con el compromiso de mejora continua de la calidad que hemos adoptado de las normas ISO. Innovaciones tales como la fabricación de gran cantidad de modelos de tensores con rodamiento doble, lo que aumenta la vida útil de la pieza, disminuyendo vibraciones e incrementando tanto su capacidad de carga como su velocidad rotacional Respondiendo a una inquietud de su red de distribuidores, desde Noviembre del 2007 **ALYCO S.R.L.** inició con destacado éxito, la producción de los Kits **EM euromotor** de Tensores + Correa de distribución **FLENNOR**, que llega en este momento a más de 130 modelos de Kits diferentes. Durante los años 2007 y 2008, gracias a la incorporación de dos nuevas máquinas de control numérico de última generación, **ALYCO S.R.L.** triplica la capacidad de producción de tensores. En el año 2008, aumenta la superficie del área de mecanizado, disponiendo en línea continua el mecanizado, los controles dimensionales, el armado y el control final de la producción de tensores de correa, logrando integrar y optimizar todo el proceso productivo, en el que se incorpora además la identificación de la marca, el código y la partida, grabadas en cada una de las piezas, a fin de garantizar la trazabilidad del producto, tal como lo exigen las normas internacionales. En concordancia con una muy estrecha y consolidada relación con **FLENNOR GmbH**, **ALYCO S.R.L.** ha fabricado más de 50 modelos diferentes de tensores, que la empresa alemana utiliza en los Kits de correa+tensores, para ser distribuidos en toda Europa. Además realiza exitosamente exportaciones a diferentes países de Sudamérica y el mundo.

EM euromotor®



La historia de ALYCO S.R.L. - The history of ALYCO S.R.L. - La historia de ALYCO S.R.L. - The history of ALYCO S.R.L. - La historia de ALYCO S.R.L. - The history of ALYCO S.R.L.

ALYCO S.R.L., a family-owned company sited in the west of the city of Buenos Aires, begins its activities in 1996, and it is growing steadily since that moment. In the year 1999 Alyco registers its brand **EM euromotor** as a trade mark, making at first automotive filters. In the year 2000, **Alyco S.R.L.** decides to renew its way of selling, passing to sell only through its net of distributors, which is getting larger through the years. During the year 2001 **Alyco S.R.L.** becomes the representative of the company **Fleenor GMBH**, sited in Düsseldorf (Germany), and begins to import the **FLENNOR** belts, having today a very wide range of more than 1000 different codes of belts. In 2004 **Alyco S.R.L.** stops its production of filters and begins to make and sell tensioners for timing and Multi V belts, with the **EM Euromotor** brand.

ALYCO S.R.L. currently has one of the widest lines in the tensioner market, with more than 700 different models for timing and Multi V belts, ranging from the most complex automatic and hydraulic tensioners to the

simplest pulleys. **Alyco S.R.L.** put bearings of first and certified quality in the tensioners **EM Euromotor**, and that fact, together with the modern machinery used to make the tensioners and the strict quality

THE HISTORY OF ALYCO S.R.L.



control guarantee optimal results of reliability. The design and development department of **ALYCO S.R.L.** is constantly adding new models and introducing innovations according to the commitment of continuous improvement of the quality which is attached to the ISO 9000 standards. Innovations such as the making of a lot of tensioner models with double bearing, which increases the life span of the piece, diminishes the vibrations and increases the load capacity and the rotational speed. Responding to a claim of its distributors net, in November of 2007

ALYCO S.R.L. successfully begins to make the Kits **EM euromotor** of Tensioners + **FLENNOR** Timing belts, which currently are more than 130 different models of Kits. During the years 2007 and 2008, thanks to acquiring two CNC machines with the newest technology, **ALYCO S.R.L.** triples its production capacity of tensioners. In 2008, the surface of the mechanizing area is raised, putting in a continuous line the mechanizing, the measure controls, the assembling and the final control of the production of tensioners; achieving the integration and the optimization of the

whole productive process, which now adds the identification of the brand, the code and the batch in order to guarantee the traceability of the product, as stated in the international standards. According to a very close and consolidated relationship with **FLENNOR GmbH**, **ALYCO S.R.L.** has made more than 50 different models of tensioners, which the German company uses in their Kits of belt+tensioners, to be distributed through the whole Europe. Besides, **Alyco S.R.L.** successfully exports to different countries of South America and the rest of the world.



INDICE • INDEX

índice - index - índice - index - índice - index - índice - index - índice - index - índice - index



NOTA: Disfrute de nuestro catálogo o haga click en el ítem de su interés e irá directamente a la página requerida. Haciendo click en la carátula de la sección de su interés volverá a este índice.
NOTE: Enjoyment of our catalogue or do click in the article of his interest and it will go directly to the needed page. Doing click in the mask of the section of his interest it will return to this index.

índice
index
índice
index
índice
index
índice
index
índice
index
índice
index
índice
index
índice
index

	PAG
APLICACIONES APPLICATIONS	7
Alfa Romeo.....	8
Audi.....	12
BMW.....	21
Chevrolet.....	23
Chrysler.....	29
Citroen.....	31
Daewo.....	39
Daihatsu.....	42
Fiat.....	45
Ford.....	58
Honda.....	67
Hyundai.....	72

	PAG
Innocenti.....	78
Isuzu.....	80
Kia.....	82
Lada.....	85
Lancia.....	87
Land-Rover.....	93
Mazda.....	95
Mercedes Benz.....	100
Mitsubishi.....	102
Nissan	111
Peugeot	117
Proton	128
Renault	130
Rover	143

	PAG
Seat	149
Skoda	157
Subaru	160
Suzuki	163
Toyota	167
Uaz	173
Volkswagen	175
Volvo	196

EQUIVALENCIAS
CROSS REFERENCES.....204

FOTOS DE TENSORES
TENSIONER
PHOTOGRAPHS216



EM euromotor®

VERSION PDF 2010



Ø18

APLICACIONES APPLICATIONS



EM euromotor[®]

VERSION PDF 2010



Ø18

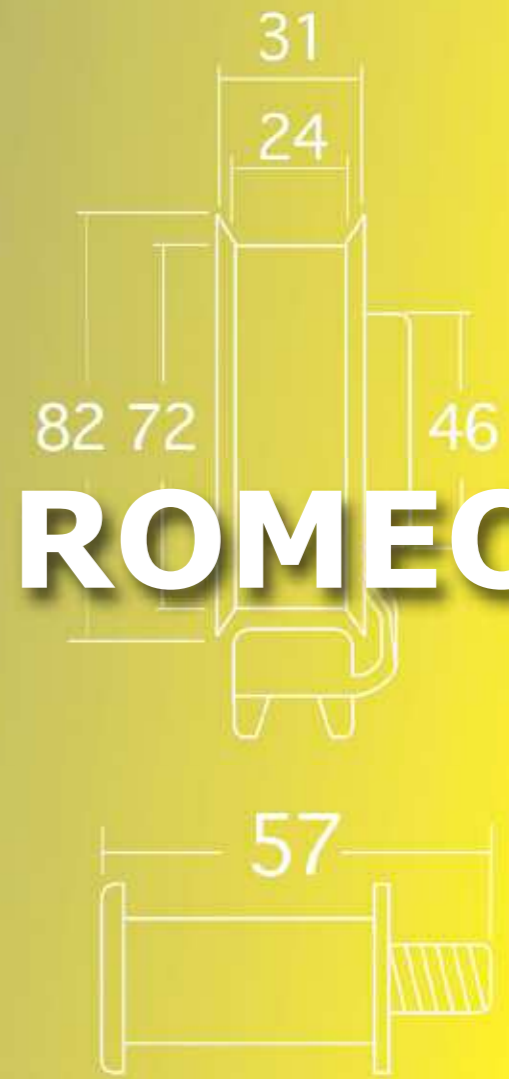

ALFA ROMEO



MODELO MODEL	MOTOR ENGINE	AÑO YEAR		CÓDIGO CODE			NOTA NOTE
		DESDE SINCE	HASTA TO	FIJO FIXED	MÓVIL MOBILE	EM euromotor®	

ALFA ROMEO 33

1.5		N	BOXER•AR30500 AR31000•AR30168 AR31010	1990	09/94		1801 1800	Derecho Right Izquierdo Left
1.7		N	BOXER•AR30500 AR31000•AR30168 AR31010	06/83	1990		1801 1800	Derecho Right Izquierdo Left
1.7 IE		N	BOXER•AR30500 AR31000•AR30168 AR31010	1990	09/94		1801 1800	Derecho Right Izquierdo Left
1.7 IE 16v	1712	N	AR30746•AR30747	1990	09/94	1937		

ALFA ROMEO 145 - 146

1.8 16v	1598	N	AR67601•AR67106	06/97			12393 12354	
2.0 16v	1970	N	AR67204•AR32301	01/96			12393 12090 12315	Arbol contrarrotante Balance shaft
1.9 TD	1930	D	AR6750•AR33601	10/94	01/99		1889 1835	
1.9 JTD	1910	D	AR32302	02/99			1950 1115	

ALFA ROMEO 147

1.6 16v	1598	N	AR32104•AR37203	10/00			12393 12354	
2.0 16v	1970	N	AR32310	01/01			12393 12090 12315	Arbol contrarrotante Balance shaft
GTA	3179	N	ARW8147B2	12/02			12152 12468	
1.9 JTD	1910	D	AR37101	10/00			1950 1115	
1.9 MJ 16v	1910	D		05/03			12467 1115	

ALFA ROMEO 155

1.6 TS 16v	1598	N	AR67601	07/96	01/98		1938 12090	
1.8 TS 16v	1747	N	AR67106	05/96	12/97		1938 12090	
2.0 TS 16v	1970	N	AR67204 AR67299	03/95			1938 12090 12315	Arbol contrarrotante Balance shaft
2.0 Turbo Q4	1995	N	AR67203	01/92	12/97		1818	

CÓDIGO CODE	EM	CÓDIGO ORIGINAL ORIGINAL CODE	CÓDIGO CODE	EM	CÓDIGO ORIGINAL ORIGINAL CODE	CÓDIGO CODE	EM	CÓDIGO ORIGINAL ORIGINAL CODE
1115		60596372 = 60812622	1800		534134 = 60504224	1801		534135 = 60504225
1818		5997325	1835		7596728 = 7596877	1889		5970621 = 7596727 = 7596876 = 60808692
1937		60504226	1938		60652129 = 60607965 = 60537975	1950		71736493 = 7763644
12090		55192323 = 60813592	12152		60810644 = 60813311	12315		60620443
12354		60621380 = 60652477 = 60814462	12393		60664403 = 60671573	12467		55187100

ALFA ROMEO

ALFA ROMEO

MODELO MODEL	AÑO YEAR	MOTOR ENGINE	CÓDIGO CODE			NOTA NOTE
			DESDE SINCE	HASTA TO	FIJO FIXED	

CÓDIGO CODE	CÓDIGO ORIGINAL ORIGINAL CODE	CÓDIGO CODE	CÓDIGO ORIGINAL ORIGINAL CODE	CÓDIGO CODE	CÓDIGO ORIGINAL ORIGINAL CODE
----------------	----------------------------------	----------------	----------------------------------	----------------	----------------------------------

ALFA ROMEO 156

2.0 TS 16v	1970	N	AR32301	09/97		12393	12090 12315	Arbol contrarrotante Balance shaft
2.0 JTS 16v	1970	N	AR937A	10/02		12393	12354 12315	Arbol contrarrotante Balance shaft
2.5 V6	2492	N	AR32402	09/97		12152 12152	12468	
2.5 V6 24v	2492	N	AR32401	09/97		12152 12152	12468	
GTA	3179	N	ARW8147B2	12/02		12152 12152	12468	
1.9 JTD	1910	D	AR32302	09/97		1950	1115	
1.9 MJ 16v	1910	D		05/03		12467	1115	
2.4 JTD	2387	D	AR325001	09/97		1950	1115	

ALFA ROMEO 164

2.0 Turbo	1955	N	AR6476	1987	1992		1823	
2.0 V6 Turbo	1955	N	AR64101	03/91	08/92	12469		
3.0 V6	2959	N	AR06410•AR06412	1987	1992	12469		
3.0 V6 QV	2959	N	AR06410•AR06412 AR63301•AR64303	1987	1992	12469		
3.0 V6 24v	2959	N	AR64304•AR64307 AR64308•AR66307	1992	1998	12152 12152	12153	

ALFA ROMEO 166

2.0 TS 16v	1970	N	AR34103•AR36301	09/98		12393	12090	
2.0 V6 Turbo	1996	N	AR34102	09/98			12468	
2.5 V6 24v	2387	N	AR34201	11/98		12152 12469	12468	
3.0 V6 24v	2492	N	AR34301•AR34302	09/98		12152 12469	12468	
2.4 JTD 20v	2387	D	841G000	09/03		12467	1115	
2.4 JTD	2387	D	AR34202	09/98		1950	1115	

<p>1115 60596372 = 60812622</p>	<p>1823 5956109</p>	<p>1950 71736493 = 7763644</p>
<p>12090 55192323 = 60813592</p>	<p>12152 60810644 = 60813311</p>	<p>12153 60580235</p>
<p>12315 60620443</p>	<p>12354 60621380 = 60652477 = 60814462</p>	<p>12393 60664403 = 60671573</p>
<p>12467 55187100</p>	<p>12468 60616799</p>	<p>12469 60810660</p>

ALFA ROMEO

ALFA ROMEO

EM euromotor®

VERSION PDF 2010



Ø18

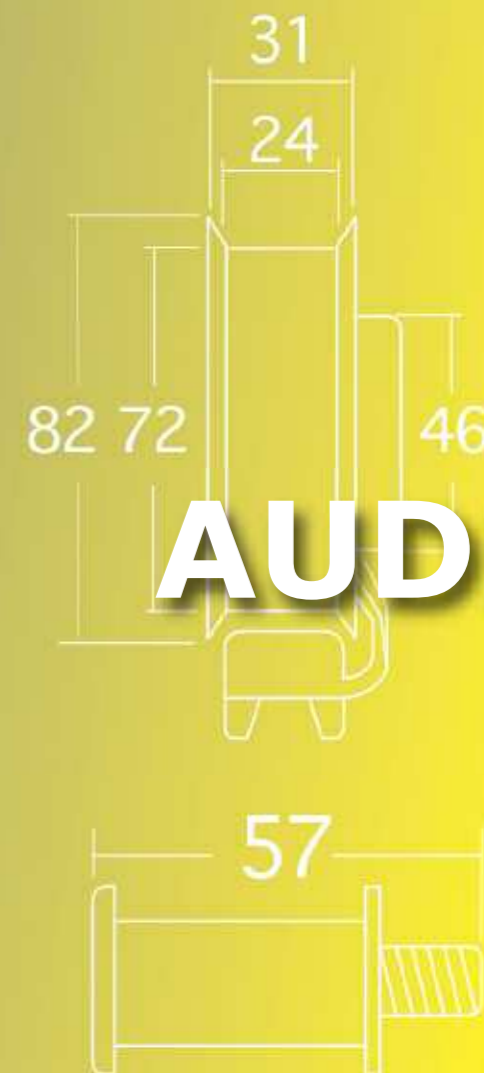

AUDI



MODELO MODEL	COMB./FUEL	MOTOR ENGINE	AÑO YEAR		CÓDIGO CODE EM euromotor®		
			DESDE SINCE	HASTA TO	FIJO FIXED	MÓVIL MOBILE	NOTA NOTE

AUDI 80

I, II, III, IV, V	1600	N	4/5 CIL	1973	01/96		1805	
I, II, III, IV, V	2000	N	4/5 CIL	1973	01/96		1805	
2.0 16v	1984	N	ACE	10/91	01/96		1808	→ 017139
1.6 D	1570	D	CR - CY	08/80	08/81		1806	
1.6 D	1588	D	JK - RA - SB	08/80	08/81		1806	
1.6 TD	1570	D	CR - CY	08/80	08/81		1806	
1.6 TD	1588	D	JK - RA - SB	08/80	08/81		1806	
1.8 TD	1896	D	AAZ - IZ	09/91	01/96	1128	1104	(90cv)
1.9 D	1896	D	IY - AAZ	09/91	01/96		1806	
1.9 TD	1896	D	IY - AAZ	09/91	01/96		1806	
2.5 TDI	2461	D	TDI VW (5 CIL.)	1992			12241	

AUDI 90

1.6 TD	1588	D	CY - RA - SB	10/85	09/91		1806	
--------	------	---	--------------	-------	-------	--	------	--

AUDI 100

1.6	1600	N	(4 CILINDROS)		11/90		1805	
2.0	2000	N	(4 CILINDROS)		11/90		1805	
2.0 16v	1984	N	ACE (4 CIL.)	01/92	06/94		1808	
2.5 TDI	2461	D	AAT - ABP (5 CIL.)	06/91	06/94		12241	
Quattro	1600	N	(4 CILINDROS)		11/90		1805	
Quattro	2000	N	(4 CILINDROS)		11/90		1805	
2.0 16v - Quattro	1984	N	ACE (4 CIL.)	01/92	06/94		1808	

AUDI A2

1.4 16V	1390	N	AVA - BBY	02/00		12438	12440 12549 12550	
1.6 FSI	1598	N	BAD	02/00		12438	12440 12549 12550	

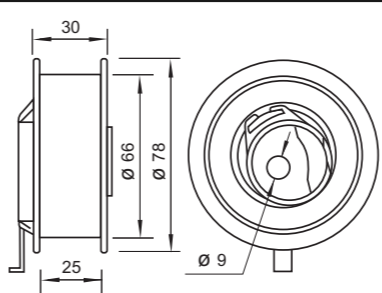
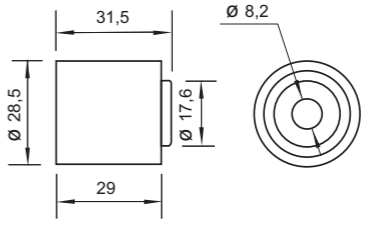
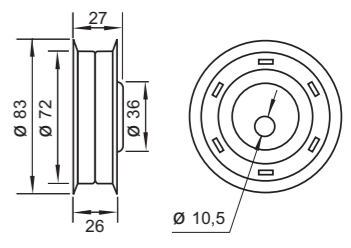
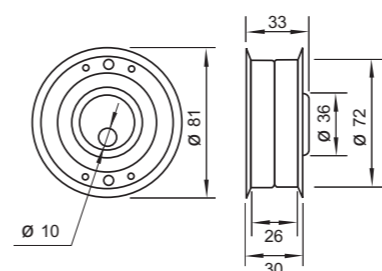
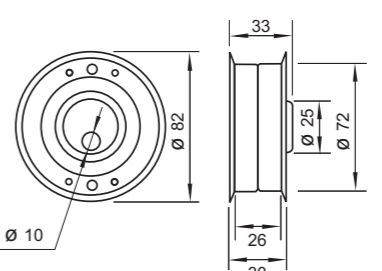
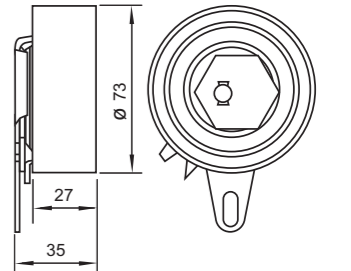
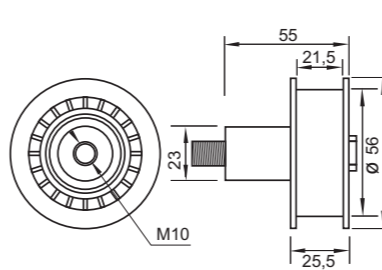
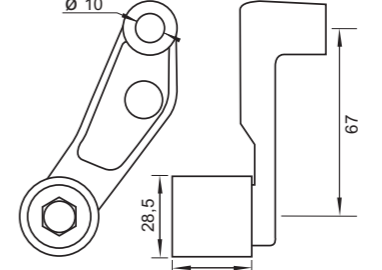
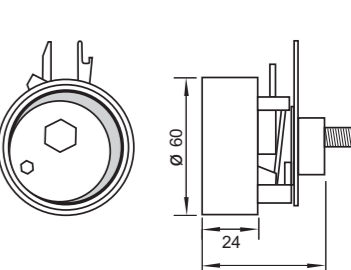
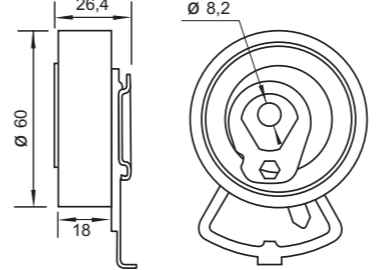
CÓDIGO CODE EM	CÓDIGO ORIGINAL ORIGINAL CODE	CÓDIGO CODE EM	CÓDIGO ORIGINAL ORIGINAL CODE	CÓDIGO CODE EM	CÓDIGO ORIGINAL ORIGINAL CODE
	028109243E		028109244		026109243A
	068109243C		027109243		074109243F
	036109244C=036109244D		036109181A		036109243E
	036109243S				

MODELO MODEL	COMB./FUEL	MOTOR ENGINE	AÑO YEAR		CÓDIGO CODE EM euromotor®		
			DESDE SINCE	HASTA TO	FIJO FIXED	MÓVIL MOBILE	NOTA NOTE

AUDI A2

1.4 TDI	1422	D	AMF	01/00		12274	12458 FD99004	Desde From chassis F8Z2-017001 Hasta Up to chassis F8Z2-024000
---------	------	---	-----	-------	--	-------	------------------	---

AUDI A3



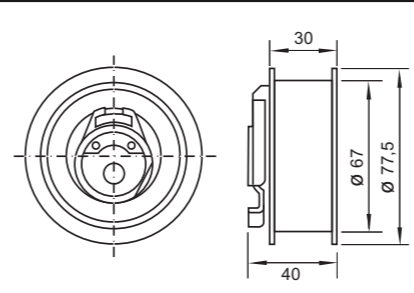
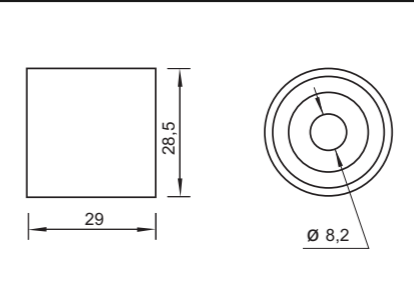
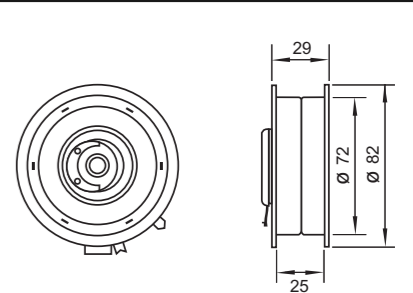
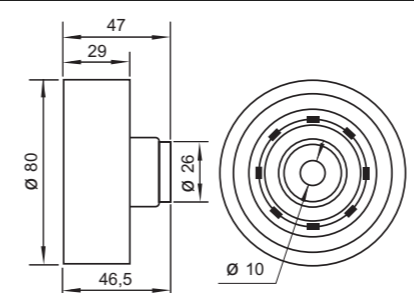
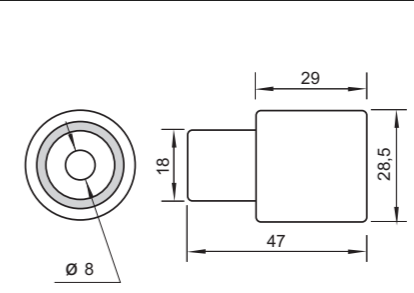
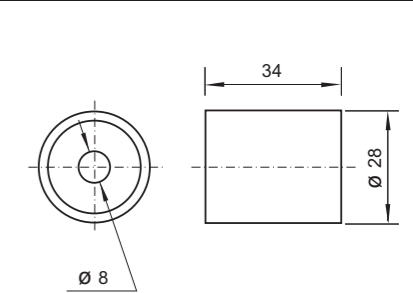
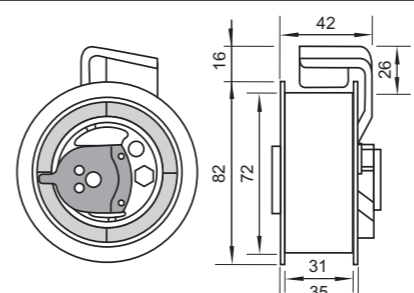
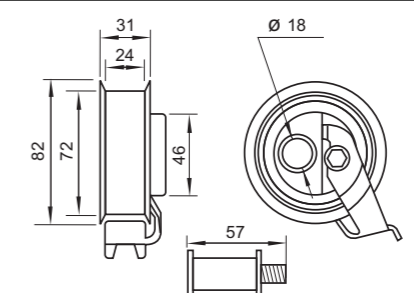
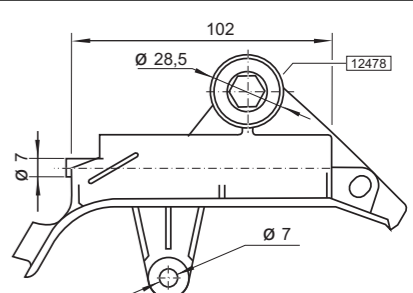
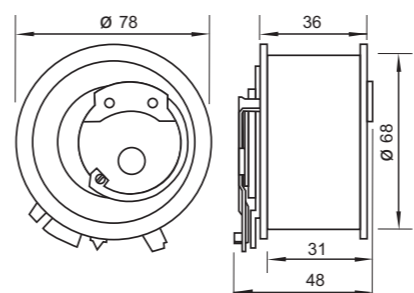
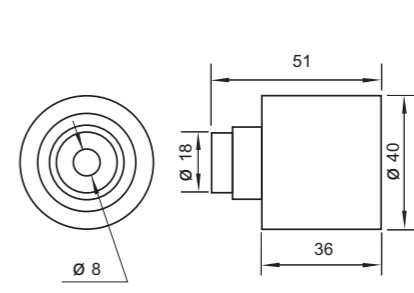
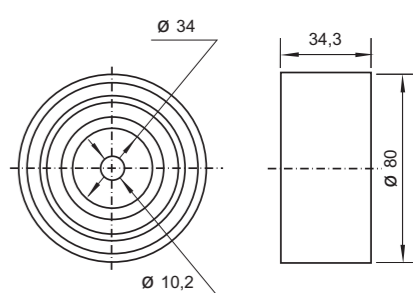
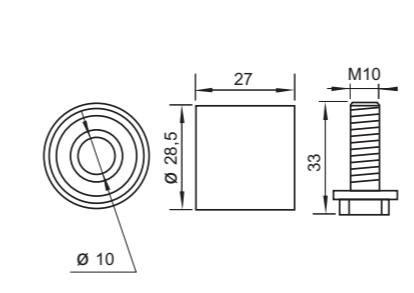
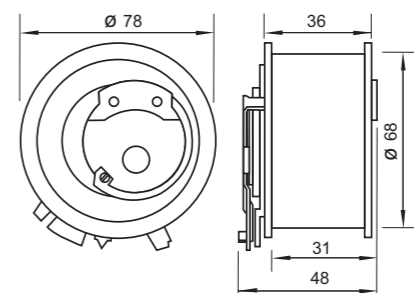
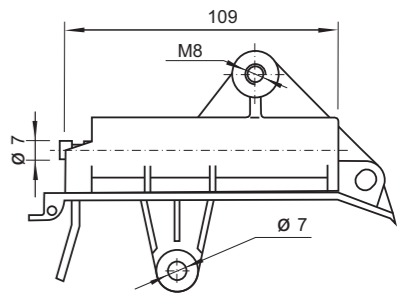

1.6	1595	N	AEH - AKL - APF AVU	09/96	07/03		1157	
1.8 20v	1781	N	AGN - APG	09/96	07/03	1131	12240 12478	
1.8 20v TURBO	1781	N	AGU - AUM - ARX ARZ - AGA	12/96	07/03	1131	12240 12478	
1.8 20v TURBO	1781	N	ARY - AJP - AUQ APP	10/98	07/03	1131	12240 12478	
1.9 TDI	1896	D	ALH	09/96		1166 1167 1131	1107	(110 cv) Hasta el motor Up to engine 500000
1.9 TDI	1896	D	ALH	09/96		1166 1167 1131	1107	(110 cv) Desde el motor From engine 500001
1.9 TDI	1896	D	AGR	09/96		1166 1167 1131	1107	(110 cv) Hasta el motor Up to engine 565000
1.9 TDI	1896	D	AGR	09/96		1166 1167 1131	1107	(110 cv) Desde el motor From engine 565001
1.9 TDI	1896	D	AHF - ASV	08/97		1166 1167 1131	1107	(110 cv) Hasta el motor Up to engine 595000
1.9 TDI	1896	D	AHF - ASV	08/97		1166 1167 1131	1107	(110 cv) Desde el motor From engine 595001
1.9 TDI	1896	D	ASZ - ATD	01/00		12238 FD99004	12239	(130 cv)
1.9 TDI	1896	D	AKC - BKG	01/03		12474	12458	
2.0 TDI	1968	D	AZV - BKD - BKC	01/03		12474 12475	12598	

CÓDIGO CODE EM	CÓDIGO ORIGINAL ORIGINAL CODE	CÓDIGO CODE EM	CÓDIGO ORIGINAL ORIGINAL CODE	CÓDIGO CODE EM	CÓDIGO ORIGINAL ORIGINAL CODE
	038109243N		058109244		06A109479
	038109244B		038109244E		045109244A
	045109243C		06B109243D		06B109477
	038109243M		038109244J		03G109244
	06B109244		03G109243		045109479B

MODELO MODEL	COMB./FUEL	MOTOR ENGINE	AÑO YEAR		CÓDIGO CODE EM euromotor®		
			DESDE SINCE	HASTA TO	FIJO FIXED	MÓVIL MOBILE	NOTA NOTE

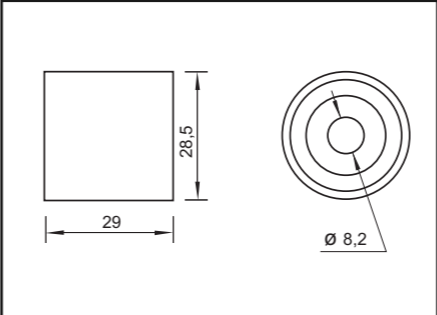
AUDI A4

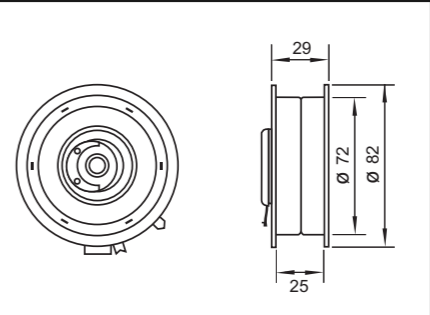
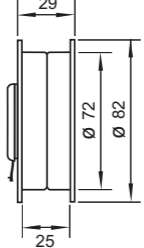
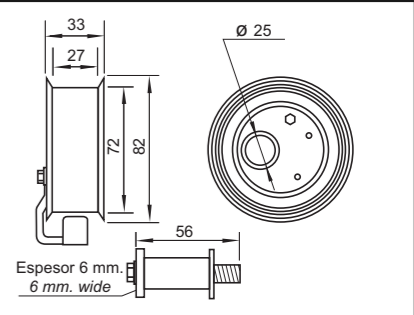
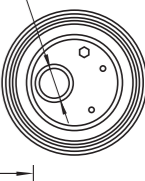
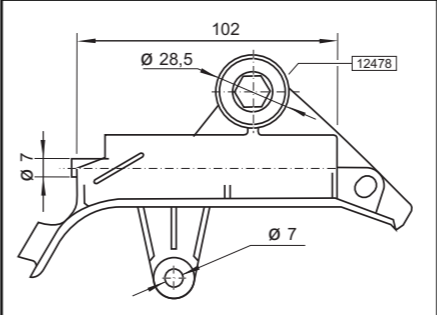
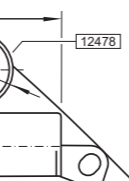
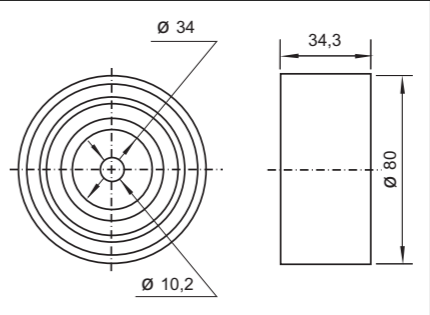
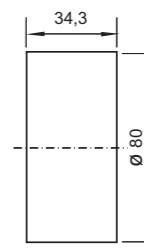
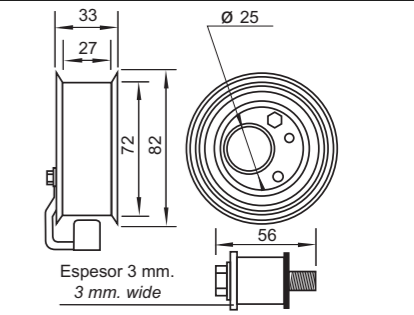
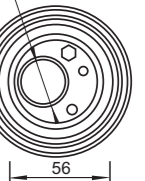
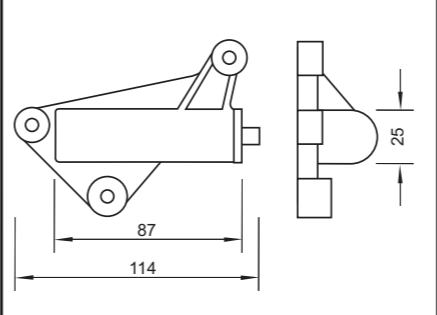
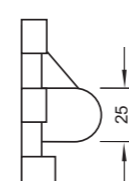
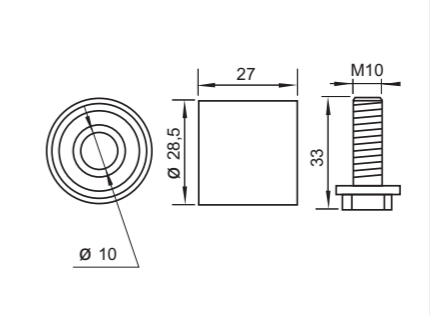
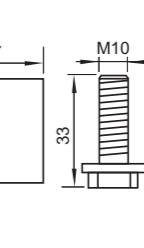
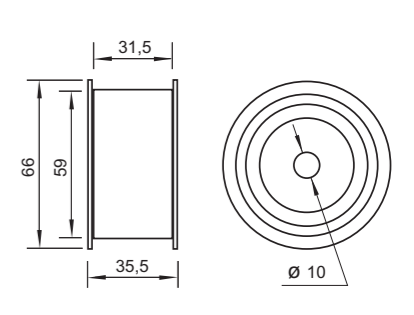
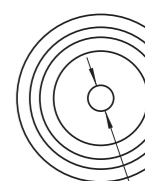
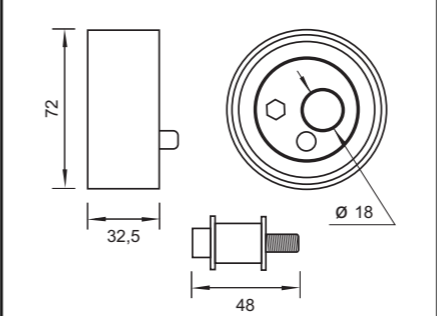
1.6	1595	N	ALZ - AHL - AVU ANA - ARM	01/95		1157	(102 cv)
1.8 20v	1781	N	AEB - ADR - AJL APT - APU - ANB	01/95		1131	Hasta Up to chassis F8DT155009
1.8 20v	1781	N	ADR	01/95		1131	Hasta Up to chassis 8D-T-155009
1.8 20v	1781	N	ADR - AEB	01/95		1131	Desde From chassis 8D-T-155010
1.8 20v TURBO	1781	N	ADR	01/95		1131	Hasta Up to chassis 8D-T-155009
1.8 20v TURBO	1781	N	ADR - AEB	01/95		1131	Desde From chassis 8D-T-155010
1.8 20v TURBO	1781	N	AWT	01/97		12240	Hasta Up to chassis F8D1042384
1.8 20v TURBO	1781	N	ARK	01/98		1131	12228 12478
1.8 20v TURBO	1781	N	AEB - ADR - AJL APT - APU - ANB	01/99		1131	Hasta Up to chassis F8DT155009
1.8 20v TURBO	1781	N	AEB - ADR - AJL PT - APU - ANB	01/99		1131	Desde From chassis F8DT155010
2.0 20v	1984	N	ALT	11/00		12478	12573 12571
2.0 FSI	1984	N	AWA	07/02		12478 12475	Desde From chassis F8E-5-00001
2.8 30v	2771	N	ACK - ALG	03/96		12479	12480 FD99200 FD99014
2.8 30v	2771	N	ACK - ALG - AMX APR - AQD - ATX	03/96		12479	Desde From chassis 12480 12572 FD99014

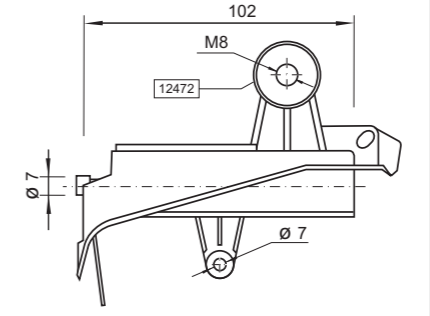
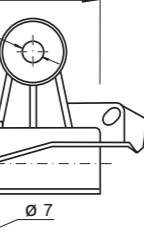
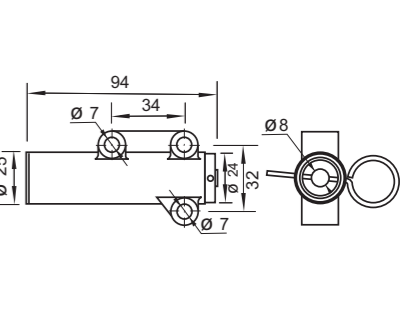
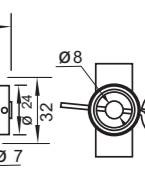
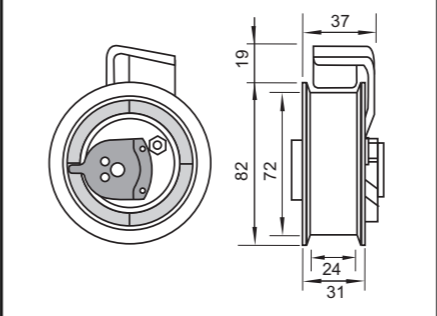
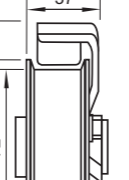
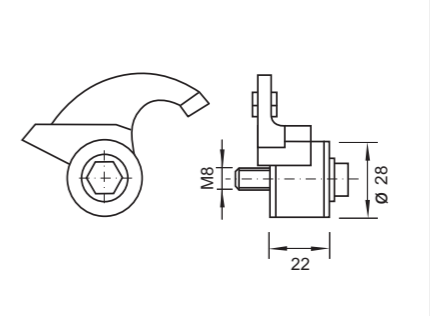
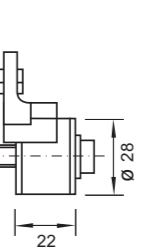
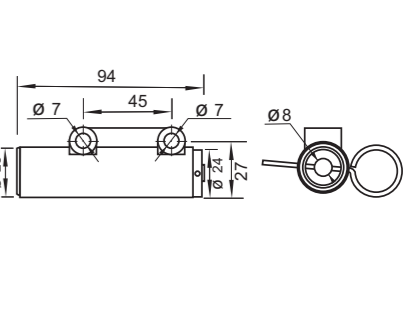
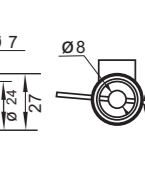
CÓDIGO CODE EM	CÓDIGO ORIGINAL ORIGINAL CODE	CÓDIGO CODE EM	CÓDIGO ORIGINAL ORIGINAL CODE	CÓDIGO CODE EM	CÓDIGO ORIGINAL ORIGINAL CODE
					
1131	058109244	1157	06A109479	12228	058109243C / E / F
					
12242	06B109477	12475	03G109244	12476	058109243D
					
12477	058109479B	12478	06B109244	12479	078109244H
					
12480	078109243Q	12571=FD99199	06B109477A	12572=FD99001	078109479E
					
12573	06B109243B	FD99014	078109487A	FD99200	078109479B

MODELO MODEL	COMB./FUEL	MOTOR ENGINE	AÑO YEAR		CÓDIGO CODE EM euromotor®		
			DESDE SINCE	HASTA TO	FIJO FIXED	MÓVIL MOBILE	NOTA NOTE

AUDI A4

3.0V6	3000	N	ASN - BBJ	01/01		12482	12481 12483 FD99021	
1.9TDI	1896	D	AHH	01/95	12/00	1128	1104	(90cv)
1.9TDI	1896	D	AJM - ATD - AUY ASZ - ARL	01/98		12238 FD99004	12484	→ 185670
1.9TDI	1896	D	AJM - ATD - AUY ASZ - ARL	03/00		12238 FD99004	12239	185670 →
2.5TDIV6	2496	D	AFB - AKN	08/97		12575	12574 12570 FD99002 FD99003	
2.5TDIV6	2496	D	AKE - AVL - AYM	05/00		12575	12574 12570 FD99003 FD99002	

AUDI A6

1.8 20v	1781	N	ADR	12/95	12/97	1131	12228 FD99020	
1.8 20v	1781	N	AFY - ANB - APV ARK - AEB - AJL	01/97		1131	12228 FD99020	Desde From chassis 4BX140001
1.8 20v TURBO	1781	N	AJP - AQE - ARH	07/97		12242 12478	12240	

CÓDIGO CODE EM	CÓDIGO ORIGINAL ORIGINAL CODE	CÓDIGO CODE EM	CÓDIGO ORIGINAL ORIGINAL CODE	CÓDIGO CODE EM	CÓDIGO ORIGINAL ORIGINAL CODE
-------------------	----------------------------------	-------------------	----------------------------------	-------------------	----------------------------------

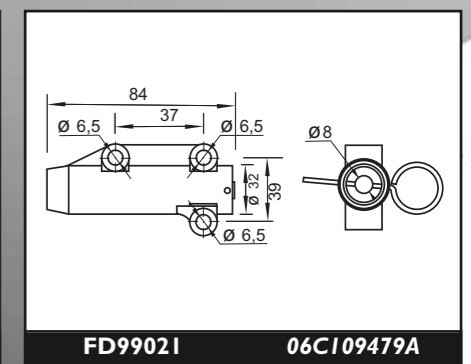
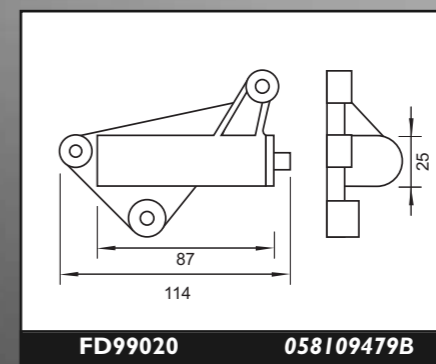
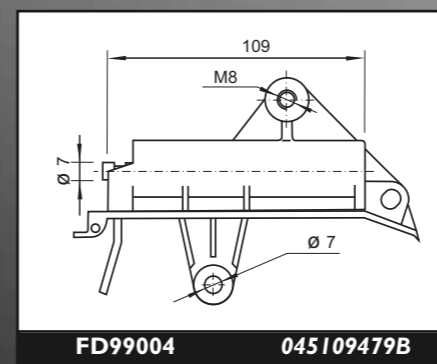
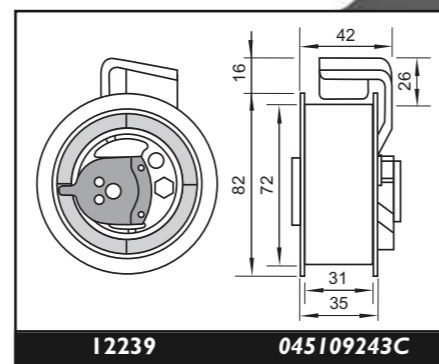
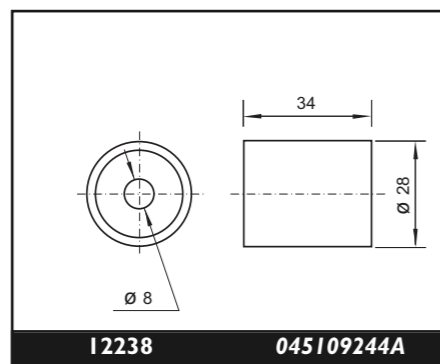
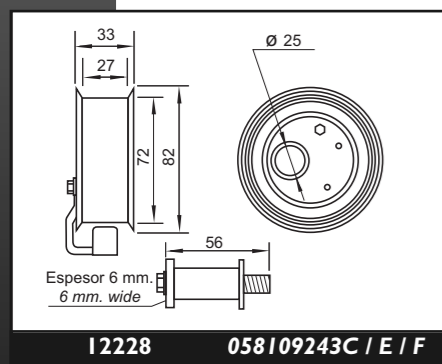
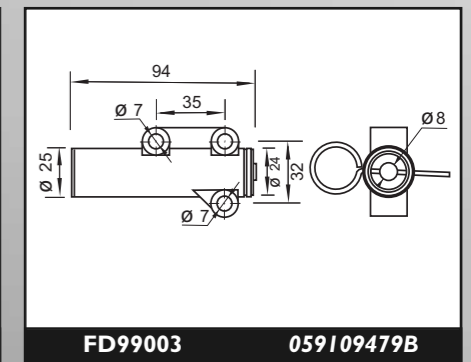
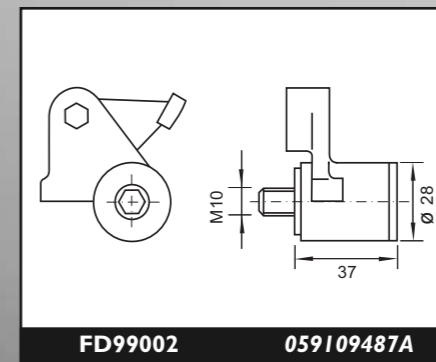
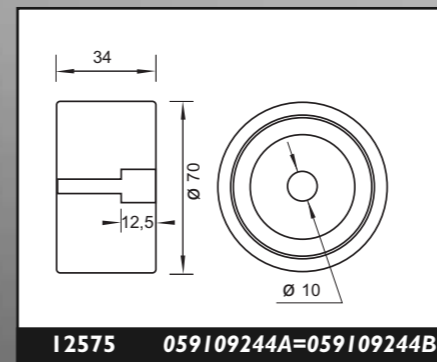
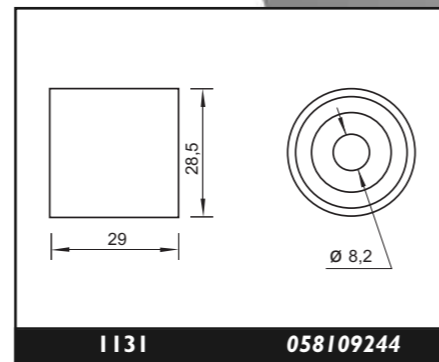
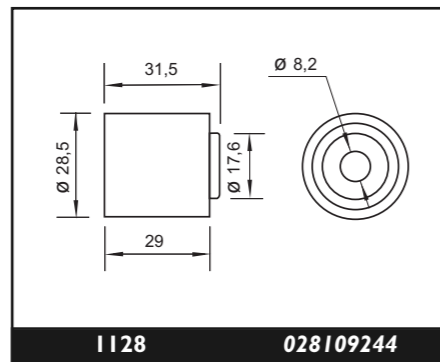
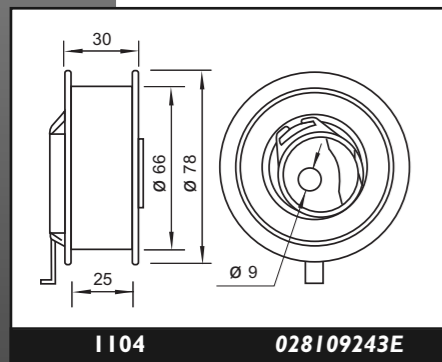
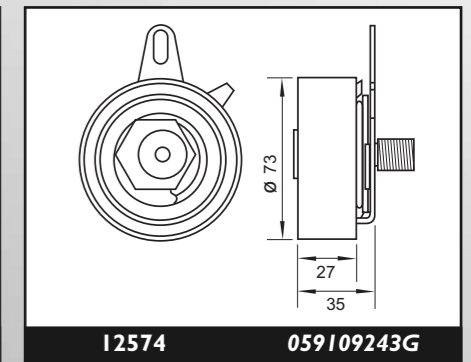
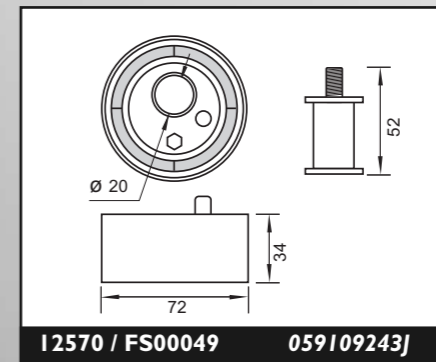
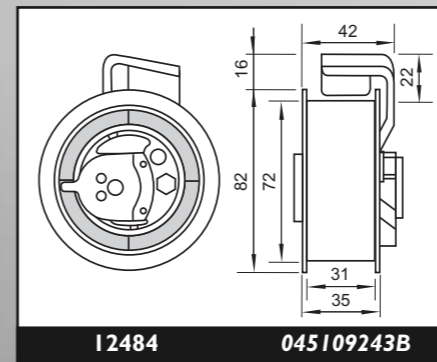
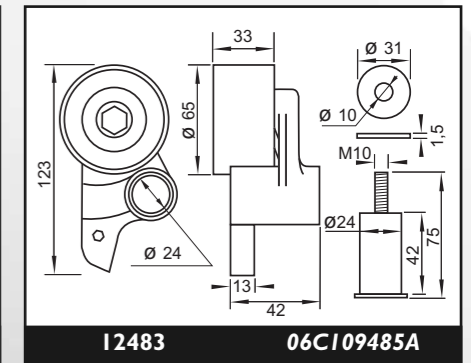
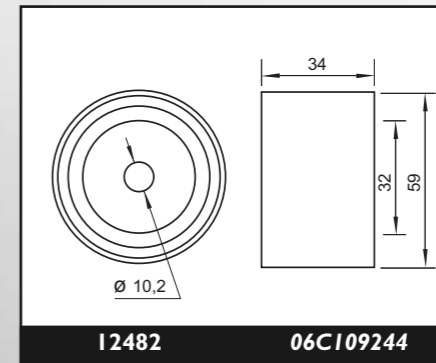
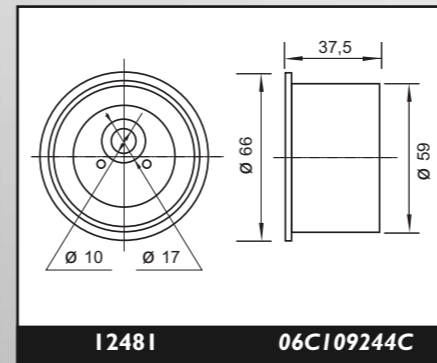
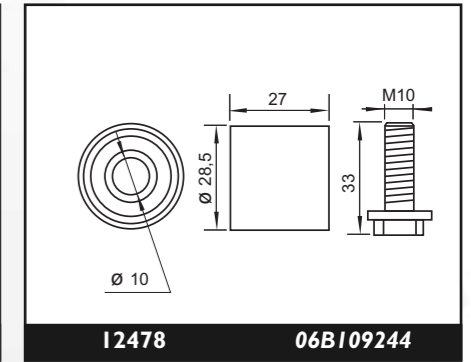
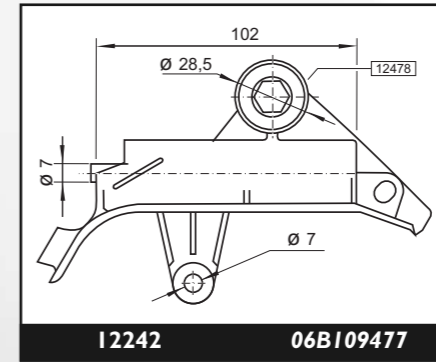
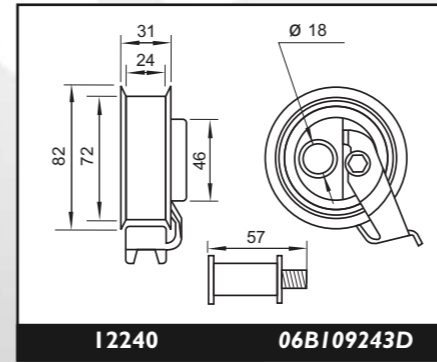

MODELO MODEL	COMB. / FUEL	MOTOR ENGINE	AÑO YEAR		CÓDIGO CODE EM euromotor®		
			DESDE SINCE	HASTA TO	FIJO FIXED	MÓVIL MOBILE	NOTA NOTE

AUDI A6

1.8 20v TURBO	1781	N	AWT	06/01		12478	12484 12571 ó FD99199	
2.0 16v	1984	N	ACE (4 CIL.)	06/94	12/97		1808	
2.0 16v	1984	N	ACE	06/94			1129	Desde motor From engine 17140
2.0 20v	1984	N	ALT	11/00		12478	12484 12571 ó FD99199	
2.4	2393	N	AGA-AJG-ALW-ALF- ASM-AMM-AML-ARJ- APZ-APS-APC-ARN	04/97		12479	12480	
2.7	2671	N	AJK -ARE - BDV - ACK - ALG - AGE	12/97		12479	12480	
2.8 30 v	2771	N	APR - AQD - AMX AGE - ALG	10/95		12479	12480 12572 ó FD99001 FD99014	
3.0 30 v	2998	N	ASN - BBJ	08/01		12482	12481 12483 FD99021	
3.7V8	3697	N	AQG - AKC	11/98	12/03	12576	12577 FS99012 FD99022 FD99003	

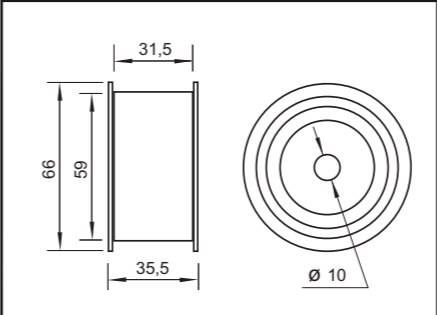
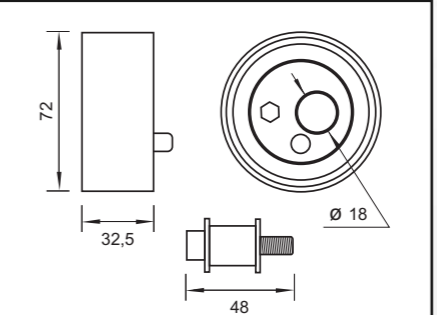
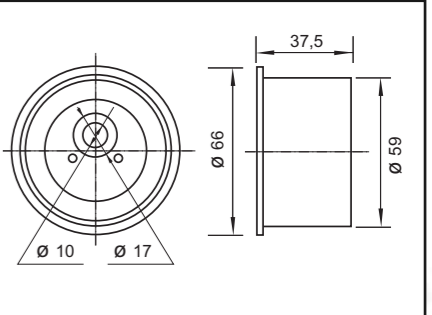
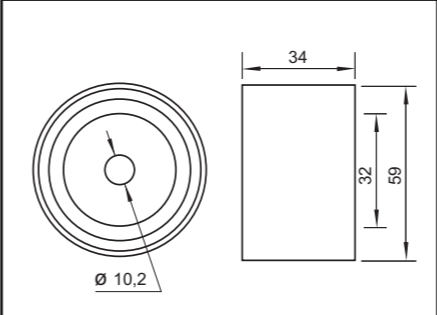
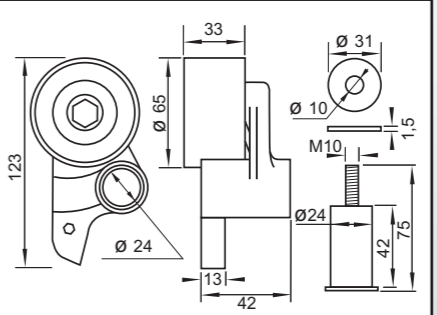
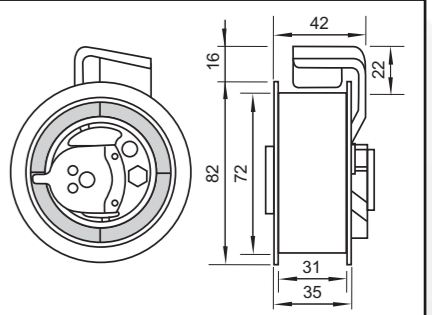
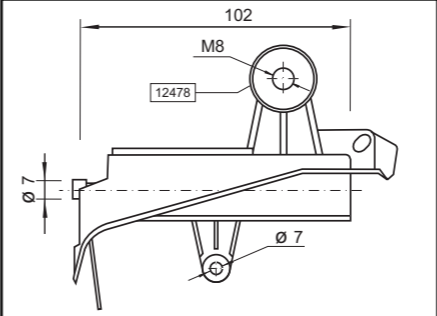
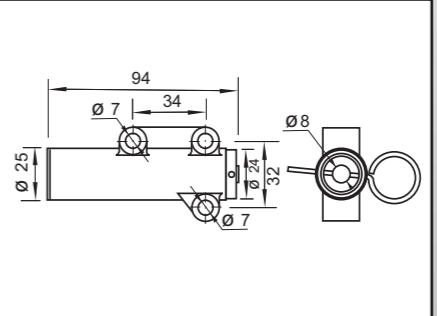
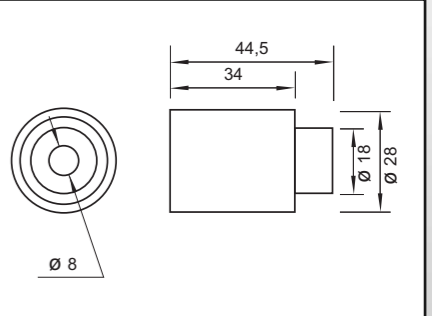
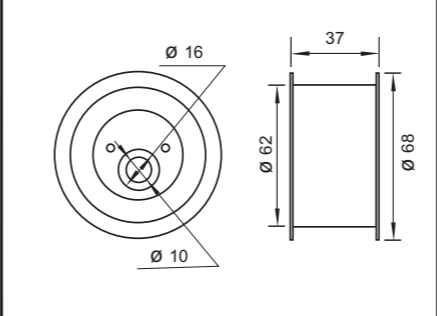
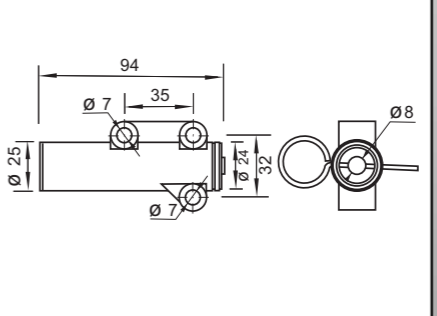
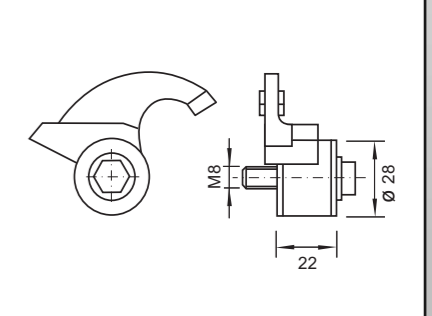
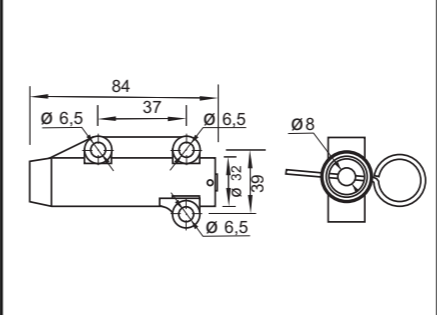
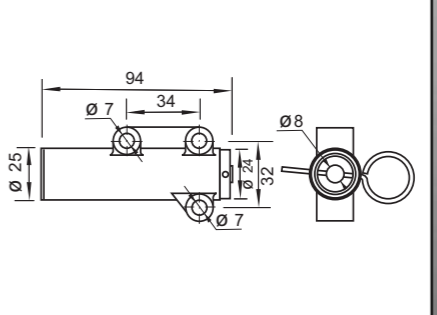
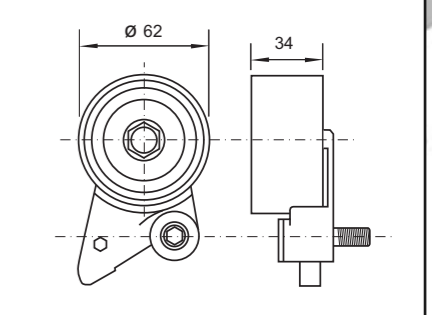
CÓDIGO CODE EM	CÓDIGO ORIGINAL ORIGINAL CODE	CÓDIGO CODE EM	CÓDIGO ORIGINAL ORIGINAL CODE	CÓDIGO CODE EM	CÓDIGO ORIGINAL ORIGINAL CODE
	078109244H		078109243Q		06C109244C
	06C109244		06C109485A		045109243B
	06B109477A		078109479E		077109244C
	077109244E		059109479B		078109487A
	06C109479A		078109479D		077109485E=077109485C

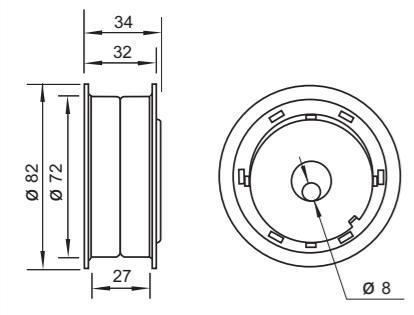

1129 051109243A

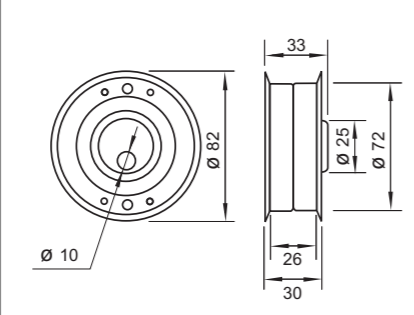

1808 027109243

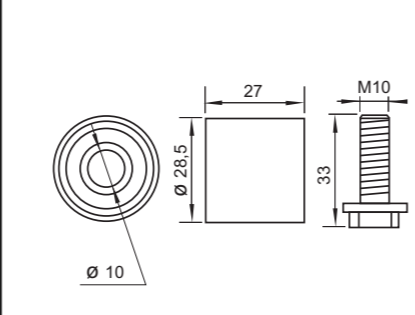

12478 06B109244

MODELO MODEL	COMB. / FUEL	MOTOR ENGINE	AÑO YEAR		CÓDIGO CODE EM euromotor®		
			DESDE SINCE	HASTA TO	FIJO FIXED	MÓVIL MOBILE	NOTA NOTE

AUDI A6

4.2 S6V8 Quattro	4172	N	AEC-AHK (8 CIL.)	06/94	12/97	FU99152 FU99152	FS99151	
1.9 TDI	1896	D	IZ - AHU	07/95		1128	1104	
1.9 TDI	1896	D	AFN - AVG	04/97		1128	1104	
1.9 TDI	1896	D	AJM	01/98		12238	12484 FD99005	
1.9 TDI	1896	D	AJM	03/00		12238	12239 FD99004	
1.9 TDI	1896	D	AVF - AWX	08/01		12238	12239	Hasta Up to chassis 4B-2-120000
1.9 TDI	1896	D	AVF - AWX	08/01		12474	12458	Desde From chassis 4B-12-120001
2.5 TDI	2496	D	AFB - AKN (6 CIL.)	07/97		12575	12570 12574 FD99003 FD99002	
2.5 TDI	2496	D	AKE - AYM (6 CIL.)	02/00		12575	12574 12570 FD99003 FD99002	
2.5 TDI	2496	D	AKE - AYM - BFC (6 CIL.) BCZ - BDG - AVL	11/01		12575	12574 12570 FD99003 FD99002	
2.0 - Quattro	1984	N	ACE (4 CIL. 16 v)	06/94	12/97		1808	

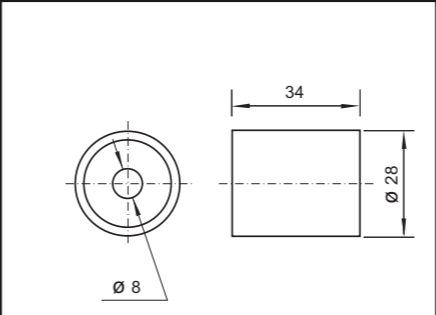
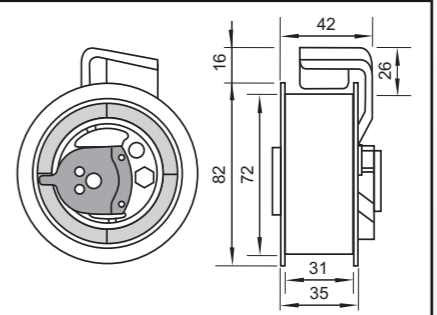
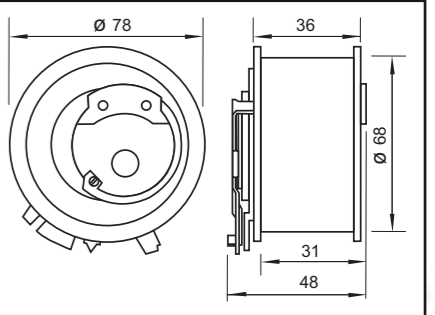
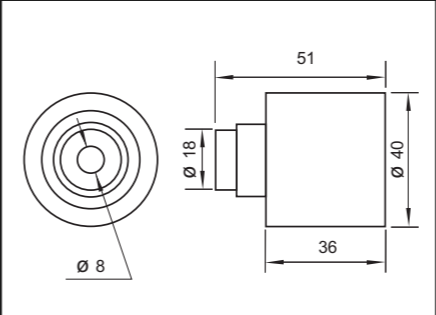
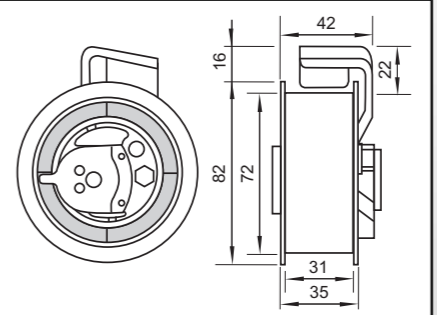
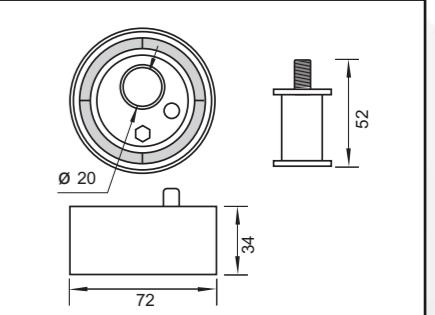
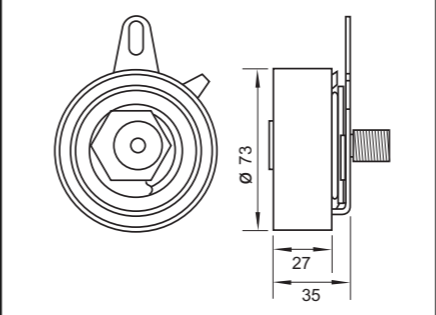
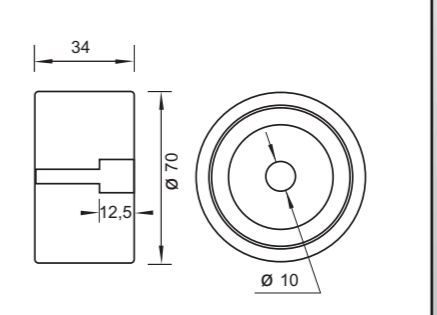
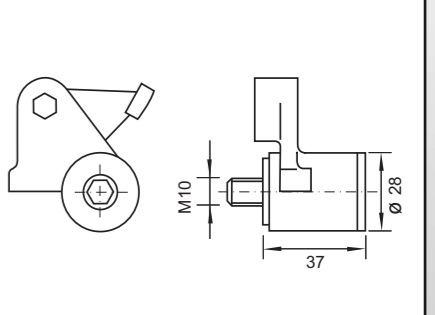
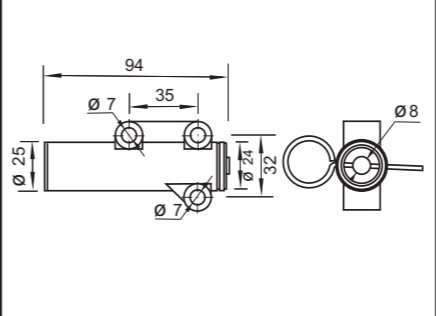
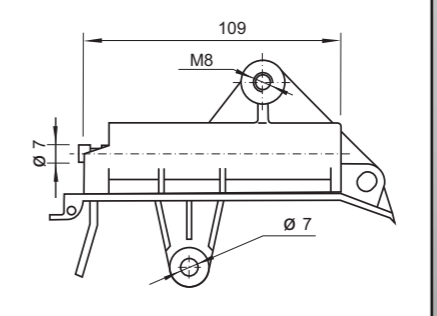
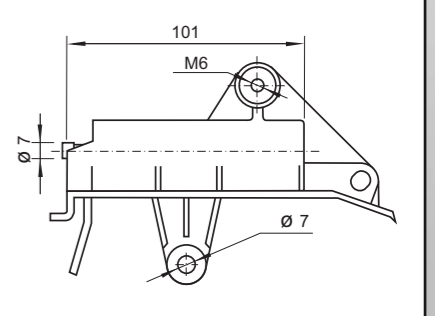
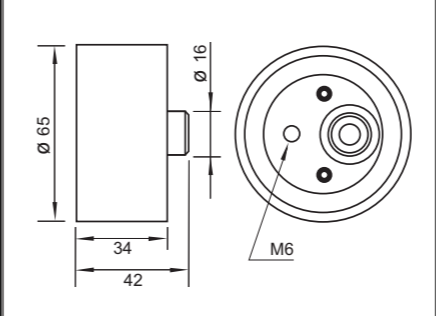
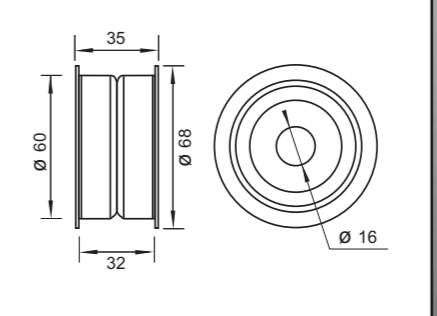
CÓDIGO CODE EM	CÓDIGO ORIGINAL ORIGINAL CODE	CÓDIGO CODE EM	CÓDIGO ORIGINAL ORIGINAL CODE	CÓDIGO CODE EM	CÓDIGO ORIGINAL ORIGINAL CODE
	045109244A		045109243C		038109243M=03G109243
	038109244J		045109243B		FS00049 059109243J
	059109243G		059109244A=059109244B		059109487A
	059109479B		045109479B		045109479C
	077109243A		077109244A		

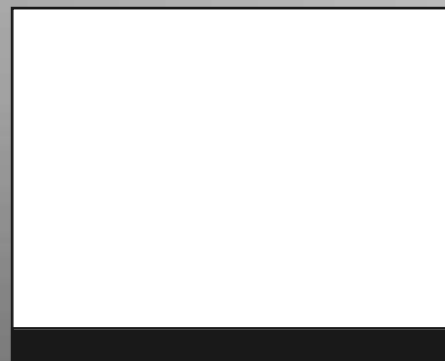
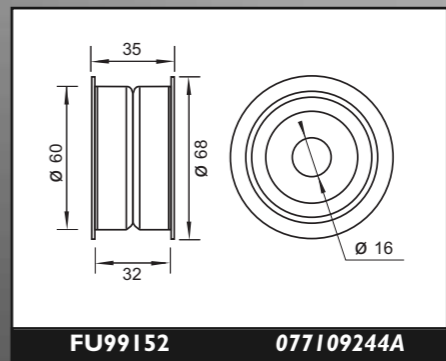
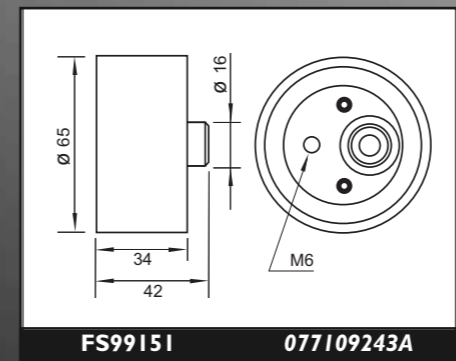
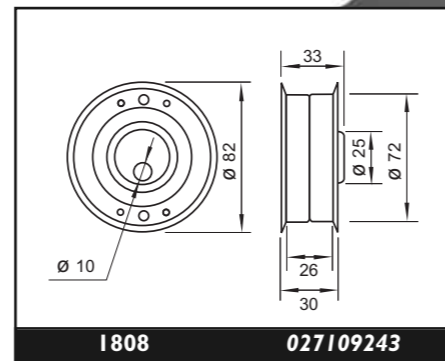
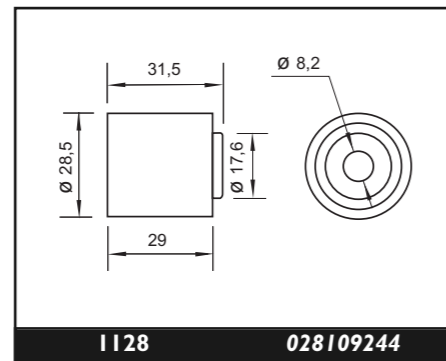
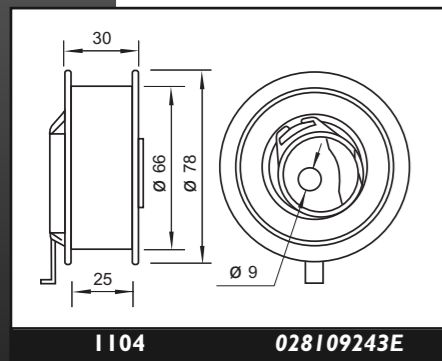

MODELO MODEL	COMB./FUEL	MOTOR ENGINE	AÑO YEAR		CÓDIGO CODE EM euromotor®		
			DESDE SINCE	HASTA TO	FIJO FIXED	MÓVIL MOBILE	NOTA NOTE

AUDI A8

2.8 30v	2771	N	ACK	03/95		12479	12480 FD99014 FD99200	Hasta Up to chassis 4DV011000
2.8 30v	2771	N	ACK	03/95		12479	12480 FD99014 FD99200	Desde From chassis 4DV011001
2.8 30v	2771	N	ALG - AMX - APR - AQD	01/98		12479	12480 FD99014 FD99200	Desde From chassis 4DV011001
3.7V8	3697	N	AEW - AKJ	07/95	09/98	FU99152 FU99152	FS99151	
3.7 40v	3697	N	AQG - AKC	11/98		12576	FS99012 12577 FD99014 FD99021	
4.2	4172	N	ARS - ASG - AWM	11/98		12576	FS99012 12577 FD99014 FD99021	
4.2V8 Quattro	4172	N	ABZ - AEM - AGH	06/94	09/98	FU99152 FU99152	FS99151	
2.5 TDI	2496	D	AFB - AKN	01/97		12575	12574 12575 FD99002 FD99003	
2.5 TDI	2496	D	AKE (6 cil.)	02/00		12575	12574 12575 FD99002 FD99003	

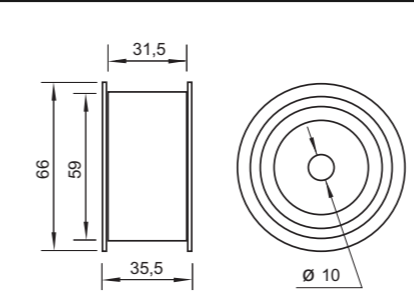
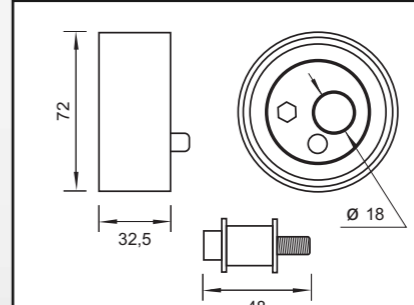
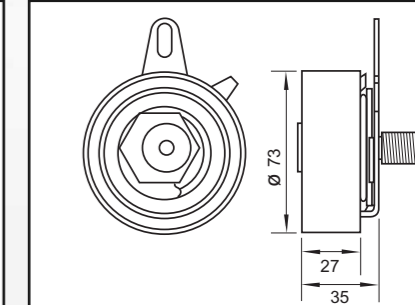
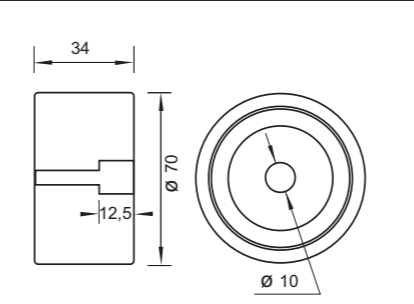
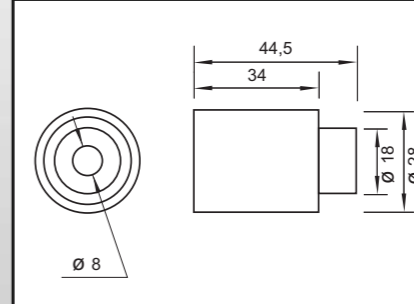
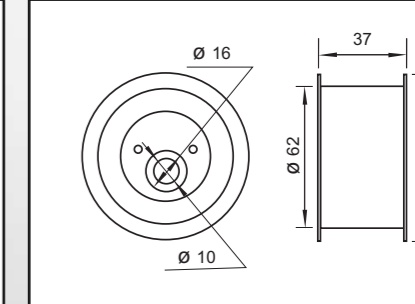
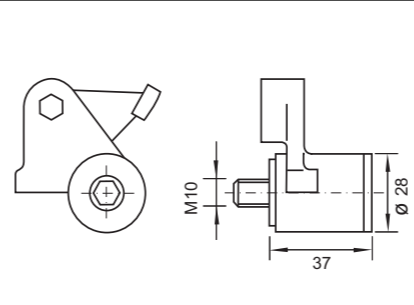
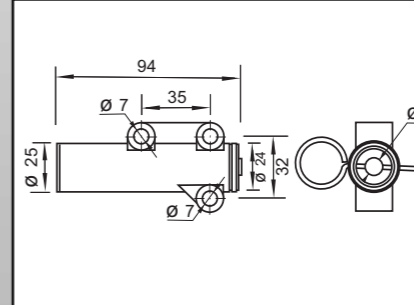
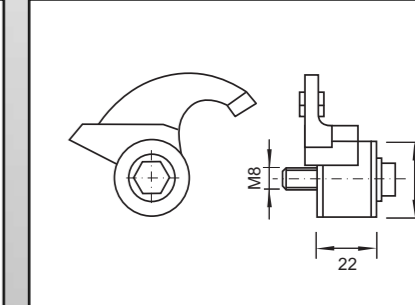
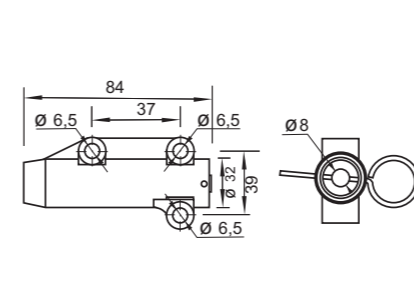
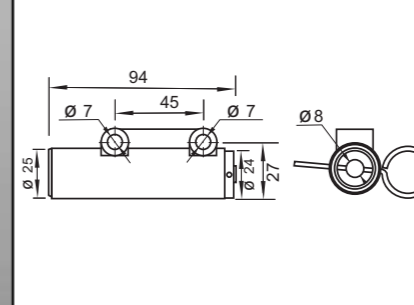
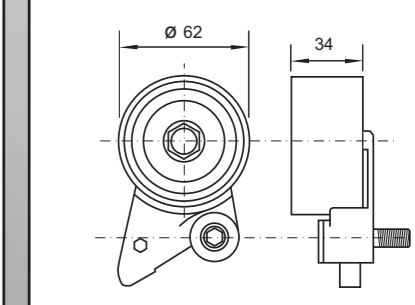
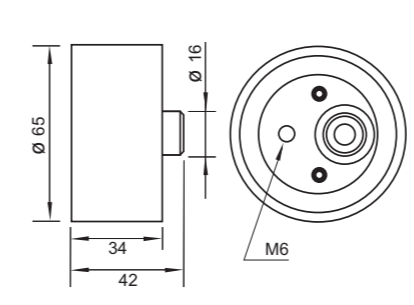
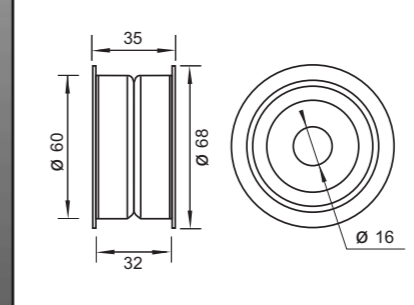
CÓDIGO CODE EM	CÓDIGO ORIGINAL ORIGINAL CODE	CÓDIGO CODE EM	CÓDIGO ORIGINAL ORIGINAL CODE	CÓDIGO CODE EM	CÓDIGO ORIGINAL ORIGINAL CODE
					
12479	078109244H	12480	078109243Q	12574	059109243G
					
12575	059109244A=059109244B	12576	077109244C	12577	077109244E
					
FD99002	059109487A	FD99003	059109479B	FD99014	078109487A
					
FD99021	06C109479A	FD99200	078109479B	FS99012	077109485E=077109485C
					
FS99151	077109243A	FU99152	077109244A		

MODELO MODEL	COMB. / FUEL	MOTOR ENGINE	AÑO YEAR		CÓDIGO CODE EM euromotor®		
			DESDE SINCE	HASTA TO	FIJO FIXED	MÓVIL MOBILE	NOTA NOTE

AUDI TT

I.8 TURBO	1781	N	AJQ - AVQ - AWP ATC - APX - AMU APP - BAM	10/98		1131 12478	12240 12242	
I.8 TURBO Quattro	1781	N	AJQ - AVQ - AWP ATC - APX - AMU APP - BAM	10/98		1131 12478	12240 12242	
Roadster I.8 TURBO	1781	N	AJQ - AVQ - AWP ATC - APX - AMU APP - BAM	10/98		1131 12478	12240 12242	
Roadster I.8 TURBO Quattro	1781	N	AJQ - AVQ - AWP ATC - APX - AMU APP - BAM	10/98		1131 12478	12240 12242	

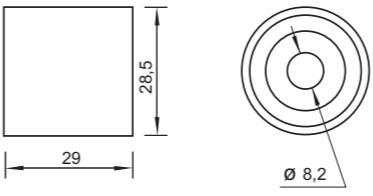
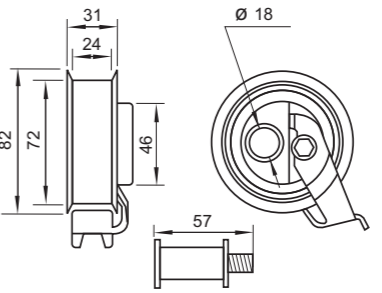
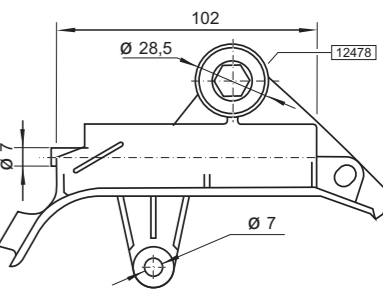
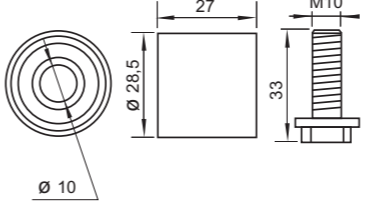
CÓDIGO CODE EM	CÓDIGO ORIGINAL ORIGINAL CODE	CÓDIGO CODE EM	CÓDIGO ORIGINAL ORIGINAL CODE	CÓDIGO CODE EM	CÓDIGO ORIGINAL ORIGINAL CODE
					
1131	058109244	12240	06B109243D	12242	06B109477
					
12478	06B109244				

EM euromotor[®]

VERSION PDF 2010



Ø18

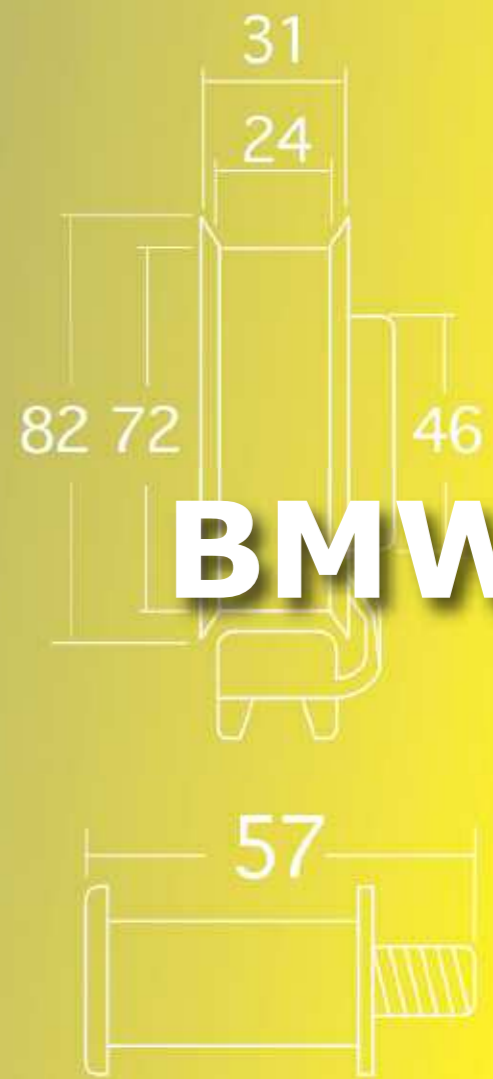

BMW



EM euromotor[®]

VERSION PDF 2010



Ø18

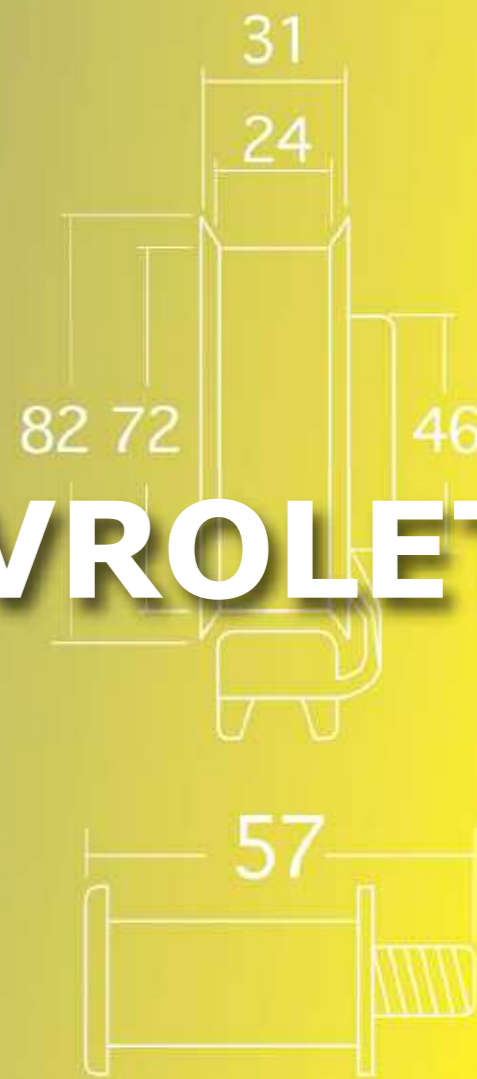

CHEVROLET



MODELO MODEL	COMB./FUEL	MOTOR ENGINE	AÑO YEAR		CÓDIGO CODE			NOTA NOTE
			DESDE SINCE	HASTA TO	FIJO FIXED	MÓVIL MOBILE	EM euromotor®	

CHEVROLET ASTRA

1.4i	1389	N	C14NZ - C14SE	09/91	09/98		1948	
1.4 Si	1389	N	C14NZ - C14SE	09/91	09/98		1948	
1.4 16v	1389	N	X14XE	02/96	09/98	1952 1953	12275	Motor Engine 02HLS11820041690
1.6 16v	1598	N	X16XEL	08/94	09/98	1952 1953	12275	
1.6i	1598	N	X16SZ - X16SZR C16NZ - C16SE	09/91			1948	Correa/ Belt 111 dientes/ teeth
1.6 Si	1598	N	X16SZ - X16SZR C16NZ - C16SE	09/91			1948	Correa/ Belt 111 dientes/ teeth
1.7 D	1700	D	I7DR	10/92	09/98	1909	1100	
1.7TD	1700	D	X17DTL	11/94	09/98	1909	1100	
1.7TDS	1686	D	I7DT - X17DT	12/91	01/98	1878	12384	
1.7TDS	1686	D	I7DT - X17DT	12/91	01/98	1878	1126	
1.8i	1796	N	C18NZ	09/91	09/98		1101	
1.8 16v	1799	N	C18XE - C18XEL X18XE	06/93	09/98	1906 1906	1100	
2.0i	1998	N	C20NE	09/91	09/98		1101	
2.0 16v	1998	N	X20XEV	02/95	01/98	1906 1906	1100	
2.0 16v	1998	N	X20XEV	02/98		1127	1100	
2.0 GSI	1998	N	C20XE	01/93	12/95	1906 1906	1100	

CHEVROLET ASTRA G

1.6 16v	1598	N	C16SFEL	02/98		1953 12386	12275	Motor Engine 02HLS11820041691
1.6	1598	N	X16SZR - X16SE	02/98			1948	
1.7 DTi 16v	1686	D	Y17DT (ISUZU)	02/00		1878	12384	
1.7 DTi 16v	1686	D	Y17DT (ISUZU)	02/00		1878	1126	
1.7 DTi 16v	1686	D	Y17DT (ISUZU)	02/00		1878	12457	Desde motor From engine 328705
1.8 16v	1796	N	Z18XE	09/00		1953 12386	12275	

CÓDIGO CODE	EM	CÓDIGO ORIGINAL ORIGINAL CODE	CÓDIGO CODE	EM	CÓDIGO ORIGINAL ORIGINAL CODE	CÓDIGO CODE	EM	CÓDIGO ORIGINAL ORIGINAL CODE
1100	90158004 = 90530125		1101	9158003=636727=636746=636738		1126	97114552=636741=636745=5636724	
1127	5636423		1878	636730=94106001=636747		1906	90530126	
1909	90411787=636418		1948	90353176=90499401		1952	9128740=5636419=5636427=5636415	
1953	912739=5636416=5636426		12275	636725=5636740=24426500=5636733		12384	636735	
12386	636420=9240033		12457	5636403 = 5636739 = 97249945				

MODELO MODEL	COMB. / FUEL	MOTOR ENGINE	AÑO YEAR		CÓDIGO CODE			NOTA NOTE
			DESDE SINCE	HASTA TO	FIJO FIXED	MÓVIL MOBILE	EM euromotor®	

CHEVROLET ASTRA H

1.8 16v	1796	N		03/04		1953 12386	12275	
---------	------	---	--	-------	--	---------------	-------	--

CHEVROLET AVEO

1.6 16v	1598	N	A16DMS	2008		12234	12214	
---------	------	---	--------	------	--	-------	-------	--

CHEVROLET CORSA A

1.2i	1195	N	C12NZ	09/89	03/93		1948	
1.4i	1389	N	C14NZ - SF	01/90	03/93		1948	

CHEVROLET CORSA B

1.2i	1195	N	I2NZ	03/93	09/00		1948	
1.4i 8v	1389	N	X14SZ	03/93	09/00		1948	
1.4i 16v	1389	N	C14SEL	09/94	09/00	1953 1952	12275	
1.6 16v	1598	N	C16SEL	03/93	09/00	1953 12386	12275	Motor Engine 02HLS11820041691
1.7 D	1686	D	I7D-X17D (ISUZU)	02/96	08/00	1878	12384	Hasta motor Up to engine 855805
1.7 D	1686	D	I7D-X17D (ISUZU)	02/96		1878	1126	Desde motor From engine 855806

CHEVROLET CORSA C

1.4 16v	1389	N	Z14XE	09/00		1953 1952	12275	
1.4 16v	1389	N	Z14XE	09/00		1953 12386	12275	Motor Engine 02HLS11820041691
1.6 8v	1598	N	Z16SE	09/00			1948	
1.8 16v	1796	N	Z18XE	09/00		1953 12386	12275	Motor Engine 02HLS11820041691
1.7 DTi	1686	D	I7D - X17D (ISUZU)	10/00	05/01	1878	1126	
1.7 DTi	1700	D	Y17 DTi (ISUZU)	06/01		1878	12457	Motor Engine 328705

CHEVROLET IPANEMA

1.8	1796	N	S18NV	09/91	12/97	12268		
-----	------	---	-------	-------	-------	-------	--	--

CÓDIGO CODE	EM	CÓDIGO ORIGINAL ORIGINAL CODE	CÓDIGO CODE	EM	CÓDIGO ORIGINAL ORIGINAL CODE	CÓDIGO CODE	EM	CÓDIGO ORIGINAL ORIGINAL CODE
1126	97114552=636741=636745=5636724		1878	636730=94106001=636747		1948	90353176=90499401	
1952	9128740=5636419=5636427=5636415		1953	912739=5636416=5636426		12214	5094008601=96350550	
12234	96103222		12268	93202400		12275	636725=5636740=24426500=5636733	
12384	636735		12386	636420=9240033		12457	5636403 = 5636739 = 97249945	

MODELO MODEL	COMB./ FUEL	MOTOR ENGINE	AÑO YEAR		CÓDIGO CODE		
			DESDE SINCE	HASTA TO	FIJO FIXED	MÓVIL MOBILE	NOTA NOTE

CHEVROLET KADETT

1.8	1796	N	S18NV	09/84	12/98		1101	
2.0	1998	N	C20NE	09/86	08/91		1101	

CHEVROLET MERIVA

1.6	1598	N	Z16SE	05/03			1948	
1.6 16v	1598	N	Z16XE	05/03		1953 12386	12275	
1.8 16v	1796	N	Z18XE	05/03		1953 12386	12275	
1.7 16v CDTI	1686	D	Y17DT - Z17DHT	09/03		1878	12457	

CHEVROLET MONZA

1.8	1796	N	I8NV/SV - E18NVR	09/86	03/94		1101	Correa/ Belt 146 dientes/ teeth
1.8	1796	N	C18LE	94	99		12268	Correa/ Belt 125 dientes/ teeth
2.0	1998	N	C20LE	94	99		12268	Correa/ Belt 125 dientes/ teeth
2.0i	1998	N	C20NE - X20SE	04/94	09/99		1101	Correa/ Belt 146 dientes/ teeth

CHEVROLET SPARK

1.0	998	N	F10MS	09/05			12329	
-----	-----	---	-------	-------	--	--	-------	--

CHEVROLET TIGRA

1.4 16v	1389	N	X14XE	07/94		1953 1952	12275	
1.6 16v	1598	N	C16SEL - X16XE	07/94		1953 1952	12275	

CHEVROLET VECTRA

1.6	1598	N	E16NZ	09/88	11/95		1948	
1.6	1598	N	I6LZ2 - C16NZ2	09/88	11/95		1101	
1.7 D	1700	D	I7DR	10/92	11/95	1909	1100	
1.7 TDS	1686	D	I7DT - X17DT	12/91	01/98	1878	12384	
1.7 TDS	1686	D	I7DT - X17DT	12/91	01/98	1878	1126	
1.7 DTI	1700	D	Y17 DTI (ISUZU)	06/91		1878	12457	Desde motor From engine 328705

CÓDIGO EM CÓDIGO ORIGINAL ORIGINAL CODE

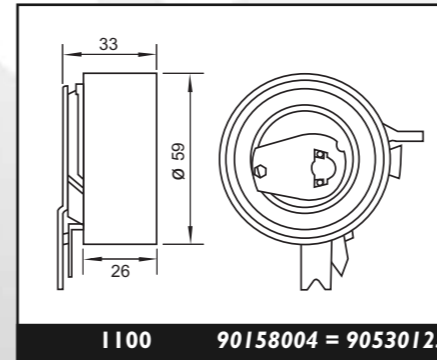

CÓDIGO EM CÓDIGO ORIGINAL ORIGINAL CODE

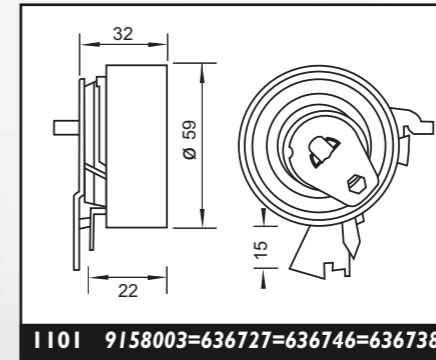

CÓDIGO EM CÓDIGO ORIGINAL ORIGINAL CODE

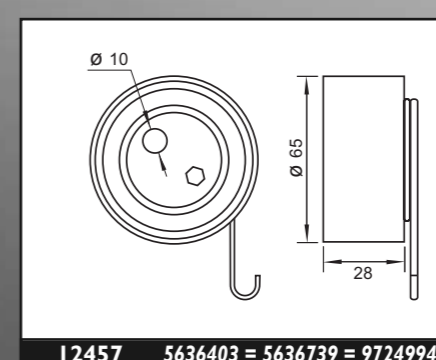
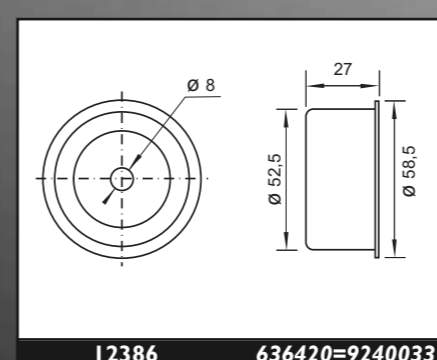
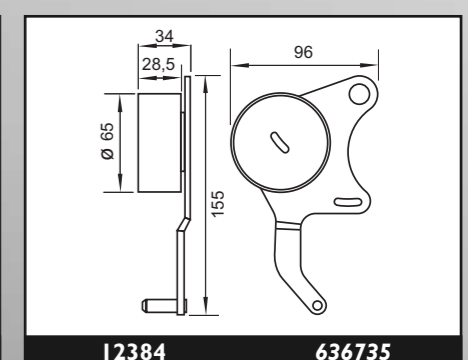
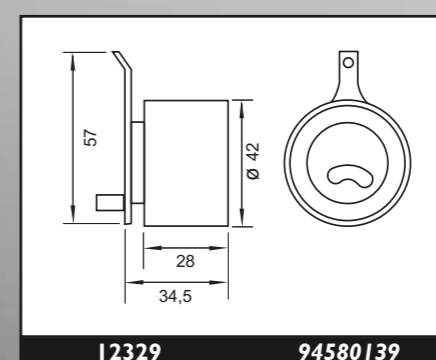
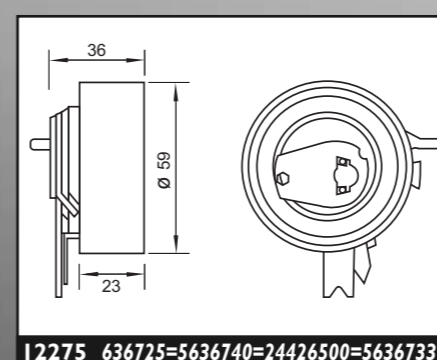
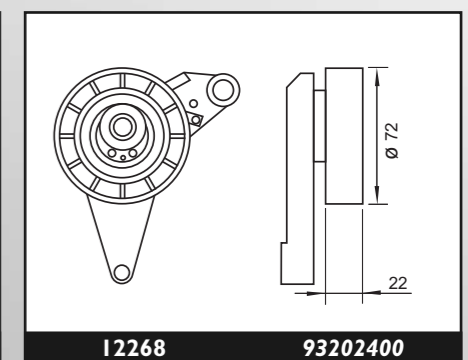
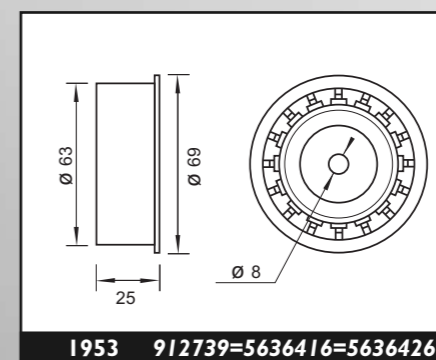
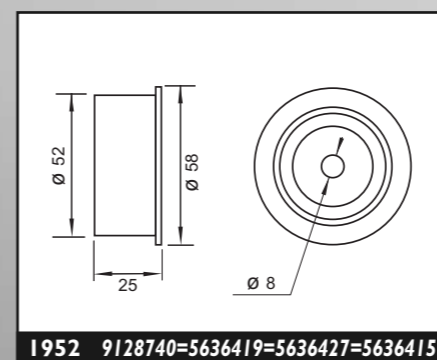
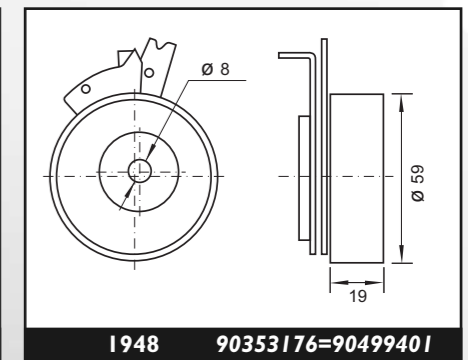
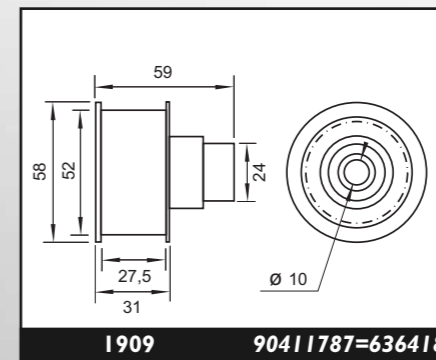
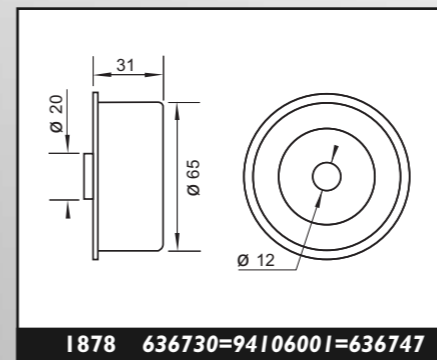
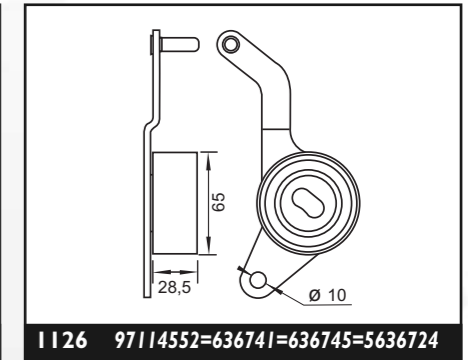

MODELO MODEL	MOTOR ENGINE	AÑO YEAR		CÓDIGO CODE			MÓVIL MOBILE	NOTA NOTE
		DESDE SINCE	HASTA TO	FIJO FIXED	EM euromotor®	EM euromotor®		

CHEVROLET VECTRA

2.0 16v	1998	N	X20XEV	06/94	11/95	1906	1100	
2.0 Turbo	1998	N	C20LET	04/93	11/95	1906	1100	Desde motor From engine I4002935
2.2	2198	N	C22SEL	10/96		1906	1100	

CHEVROLET VECTRA B

1.6 16v	1598	N	X16XEL	10/96		1953	12275	
1.8 16v	1796	N	X18XEI	10/95		1953	12275	
1.8 16v	1796	N	C18XE - X18XE	10/95	09/00	1906	1100	

CHEVROLET VECTRA C

1.8 16v	1796	N		01/03		1953	12275	
						12386		

CHEVROLET ZAFIRA

1.6 16v	1598	N	X16XEL	04/99		1953	12275	Motor Engine 02HL5117-20041690
1.6 16v	1598	N	X16XEL	04/99		1953	12275	Motor Engine 02HL5118-20041691
1.8 16v	1796	N	X18XEI	04/99		1953	12275	Motor Engine 02HL5117-20041690
1.8 16v	1796	N	X18XEI	04/99		1953	12275	Motor Engine 02HL5118-20041691
2.0 16v	1998	N	X20XEV	02/98		1127	1100	
1.7 DTL	1700	D	X17DTL	02/98		1909	1100	

Utilitarios

CHEVROLET BLAZER

2.2 8v	2178	N	2.2 EFI		12/97		1101	
2.5 D - 2.5 TD	2498	D	2.5 Maxion		12/97	12164	12163	Engran. cigüeñal Crankshaft gear E1621
2.5 D - 2.5 TD	2498	D	2.5 Maxion	01/98		1892	1968	Engran. cigüeñal Crankshaft gear E1621

CÓDIGO CODE	EM	CÓDIGO ORIGINAL ORIGINAL CODE	CÓDIGO CODE	EM	CÓDIGO ORIGINAL ORIGINAL CODE	CÓDIGO CODE	EM	CÓDIGO ORIGINAL ORIGINAL CODE
1100	90158004 = 90530125		1101	9158003=636727=636746=636738		1127	5636423	
1892	LHV 100150		1906	90530126		1907	636416	
1909	90411787=636418		1952	9128740=5636419=5636427=5636415		1953	912739=5636416=5636426	
1968	LHP 100680		12163	ERR1972		12164	ETC 8560	
12275	636725=5636740=24426500=5636733		12386	636420=9240033		E1621	70670208	

MODELO MODEL	COMB./ FUEL	MOTOR ENGINE	AÑO YEAR		CÓDIGO CODE		
			DESDE SINCE	HASTA TO	FIJO FIXED	MÓVIL MOBILE	NOTA NOTE

CHEVROLET COMBO

1.6	1389	N	X16SZ				1948	
1.7 D	1686	D	17D - X17D	07/94		1878	12384	
1.7 D	1686	D	17D - X17D	07/94		1878	1126	
1.7 TDI	1700	D	Y17 DTI (ISUZU)	06/01		1878	12457	Desde motor From engine 328705

CHEVROLET LUV

2.3	2300	N	4JA1T	08/91			12255	
2.2 D - 2.2 TD	2189	D	ISUZU	08/91			1048	

CHEVROLET S10 Pick up

2.2 8v	2178	N	2.2 EFI		12/97		1101	
2.5 D - 2.5 TD	2498	D	2.5 Maxion		12/97	12164	12163	Engran. cigueñal Crankshaft gear E1621
2.5 D - 2.5 TD	2498	D	2.5 Maxion	01/98		1892	1968	Engran. cigueñal Crankshaft gear E1621

CÓDIGO CODE	EM	CÓDIGO ORIGINAL ORIGINAL CODE	CÓDIGO CODE	EM	CÓDIGO ORIGINAL ORIGINAL CODE	CÓDIGO CODE	EM	CÓDIGO ORIGINAL ORIGINAL CODE
1048		5-12539-013-2	1101		9158003=636727=636746=636738	1126		97114552=636741=636745=5636724
1878		636730=94106001=636747	1892		LHV 100150	1948		90353176=90499401
1968		LHP 100680	12163		ERR1972	12164		ETC 8560
12255		4294287 = 94215197	12384		636735	12457		5636403 = 5636739 = 97249945
E1621		70670208						

EM euromotor®

VERSION PDF 2010



$\varnothing 18$

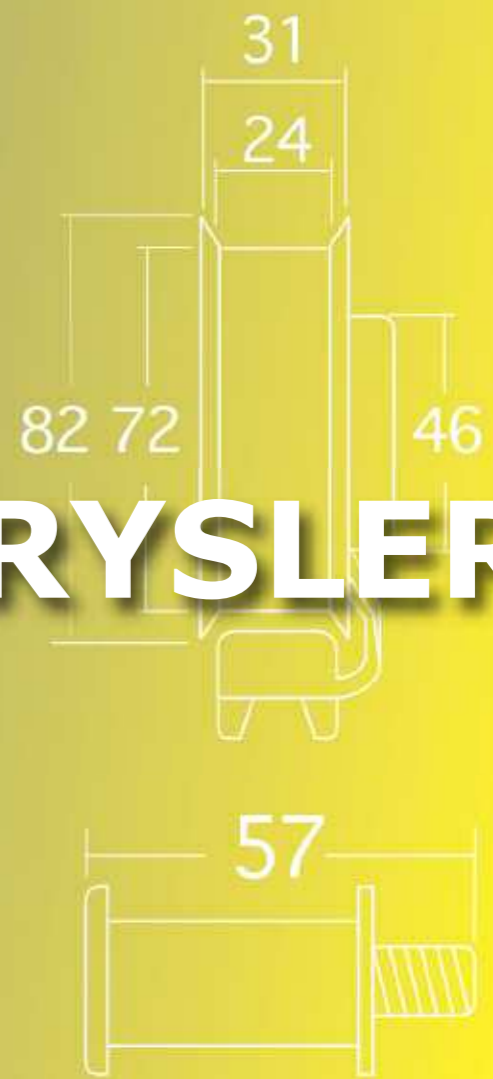

CHRYSLER



MODELO MODEL	COMB. / FUEL	MOTOR ENGINE	AÑO YEAR		CÓDIGO CODE			NOTA NOTE
			DESDE SINCE	HASTA TO	FIJO FIXED	MÓVIL MOBILE	CÓDIGO ORIGINAL ORIGINAL CODE	

CHRYSLER CHEROKEE

CHEROKEE	2068	D	J85	01/88		1857	1913	(Mot. Renault Renault engine)
----------	------	---	-----	-------	--	------	------	----------------------------------

CHRYSLER NEON

I - 1.8 16v DOHC	1798	N		09/97	08/99	12492 12180	12491	
II - 2.0 16v DOHC	1996	N		06/94	08/99	12492 12180	12491	
2.0 16v SOHC	1996	N		06/00		12180	12490	

CHRYSLER PT CRUISER

2.0 16v SOHC	1996	N		06/00		12180	12490	
2.4 16v	2429	N		06/00		14211	12491	

CHRYSLER SEBRING

2.0 16v DOHC	1996	N		06/94		12180 12180	12490	
-----------------	------	---	--	-------	--	----------------	-------	--

CHRYSLER STRATUS

2.0	1996	N		06/94		12180	12180	
2.0 16v SOHC	1996	N		12/95		12180	12490	
2.4 16v JA	2429	N		12/95		14211	12491	

CHRYSLER CARAVAN

2.0 16v SOHC	1996	N		01/95	03/01	12180	12490	
II - 2.4 16v	1996	N		01/95	02/00	14211 12492	12491	
III - 2.4 16v	1996	N		01/95	02/00	14211 12492	12491	

CÓDIGO CODE	EM	CÓDIGO ORIGINAL ORIGINAL CODE	CÓDIGO CODE	EM	CÓDIGO ORIGINAL ORIGINAL CODE	CÓDIGO CODE	EM	CÓDIGO ORIGINAL ORIGINAL CODE
1857		7700721690	1913		7700852114=7700871169	12180		04777394
12490		04884320AA	12491		0478167AB	12492		04781569AB
14211		04621450						

EM euromotor[®]

VERSION PDF 2010



$\varnothing 18$

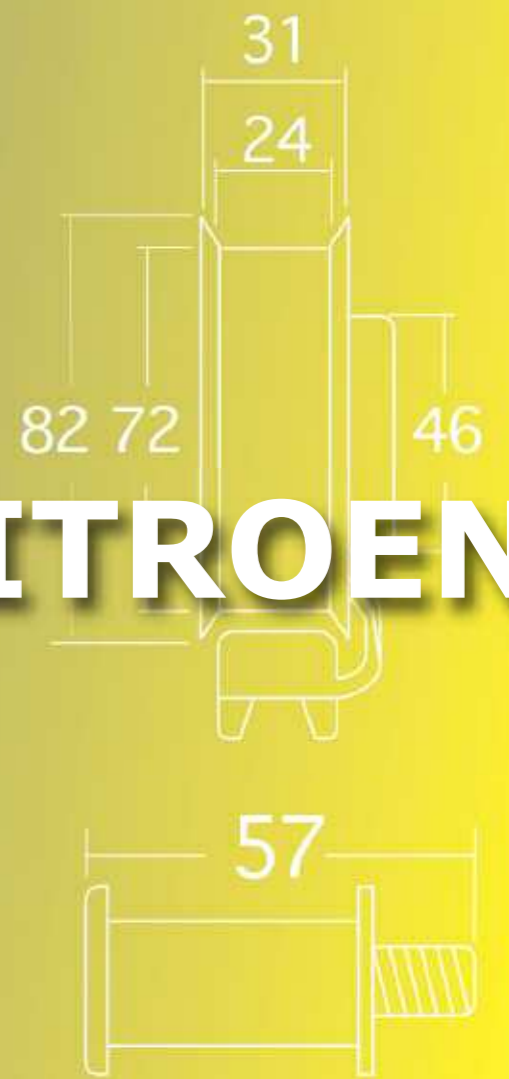

CITROEN



MODELO MODEL	MOTOR ENGINE	AÑO YEAR		CÓDIGO CODE			MÓVIL MOBILE	NOTA NOTE
		DESDE SINCE	HASTA TO	FIJO FIXED	EM euromotor®	ORIGINAL CODE		

CITROEN AXEL

I.1	I129	N	G11 / 631	01/84	03/91	1822		
-----	------	---	-----------	-------	-------	------	--	--

CITROEN AX

I.0	954	N	TU9 - C3A	07/86	12/98		1811	
I.1	I124	N	TUI - H1B	12/86	12/97		1811	
I.3 Sport	I294	N	M4A	04/87	12/88		1811	
I.4	I360	N	TU3	12/86	12/96		1811	
I.4 GTI	I360	N	TU3	12/86	12/96		1811	
I.4 D	I360	D	TUD3	09/88	12/97	1862	1861	
I.5 D	I527	D	TUD5	08/94	12/97	1862	1861	

CITROEN BERLINGO

I.1 i	I124	N	HDZ (TU1M)	07/96			1811	
I.4 i	I360	N	KFX (TU3JP)	07/96			1811	
I.6 16 v	I587	N	NFU (TU5JP4)	10/00			12451	
I.8 i	I761	N	LFX (XU7JB)	05/97			1811	
I.8 D	I769	D	I61A (XUD7)	07/98		1900	1901	
I.9 D	I905	D	DJY (XUD9A)	07/96		1900	1901	
I.9 D	I868	D	WJC (DW8)	07/98		12094	12093	
2.0 HDI	I997	D	DW10	12/99		12094	12093	

CITROEN BX

I.1	I124	N	TUI M - K1M	10/86	06/92		1811	
I.4	I360	N	TU3 A - KDY	10/82	02/93		1811	
I.6	I580	N	XU5 CP	10/82	12/90		1812	Hasta motor Up to engine -5545
I.6	I580	N	XU5 51 C	01/91	02/93		1811	Desde motor From engine -5545
I.9	I905	N	XU9	07/86	02/93		1812	Hasta motor Up to engine -5545

CÓDIGO CODE	EM	CÓDIGO ORIGINAL ORIGINAL CODE
----------------	----	----------------------------------

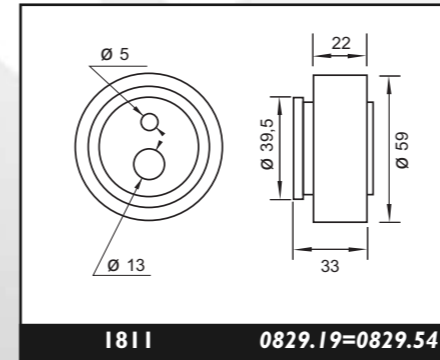

CÓDIGO CODE	EM	CÓDIGO ORIGINAL ORIGINAL CODE
----------------	----	----------------------------------

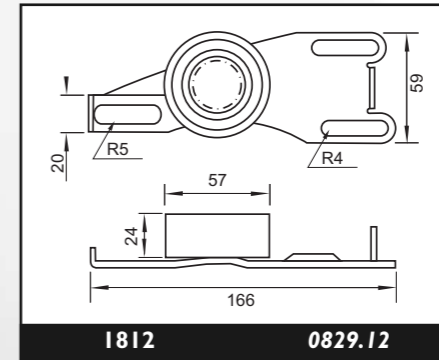

CÓDIGO CODE	EM	CÓDIGO ORIGINAL ORIGINAL CODE
----------------	----	----------------------------------

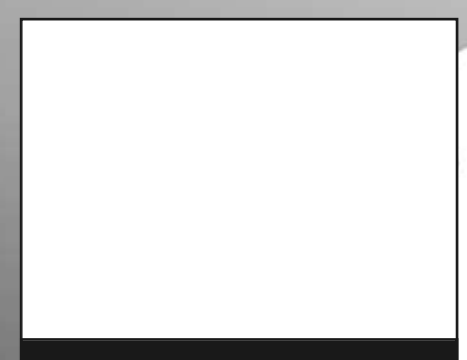
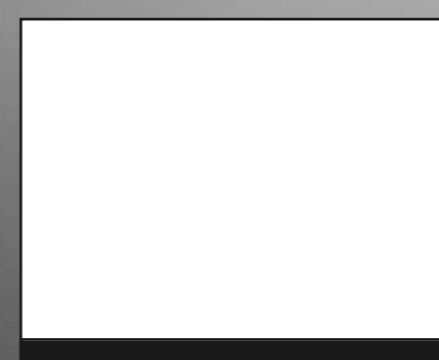
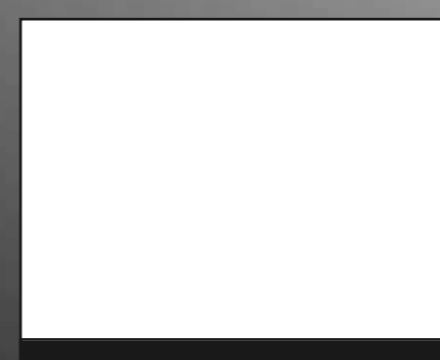
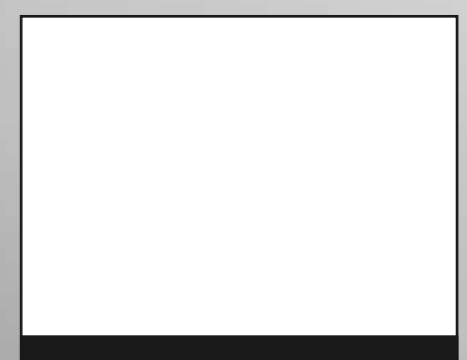
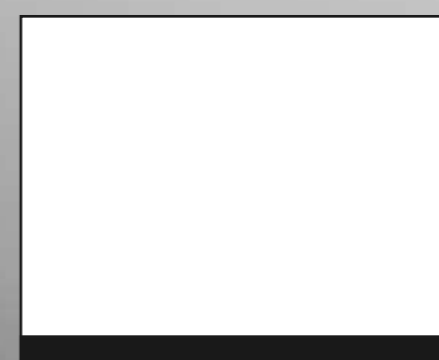
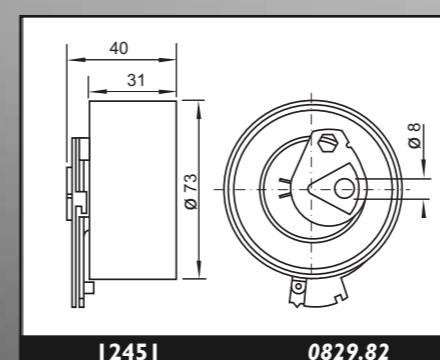
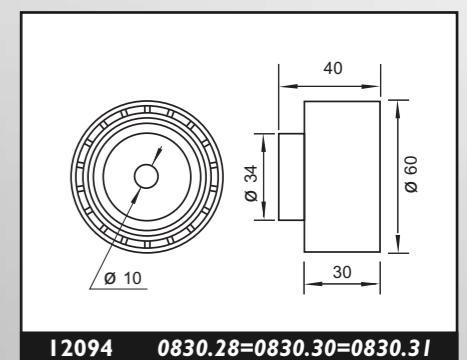
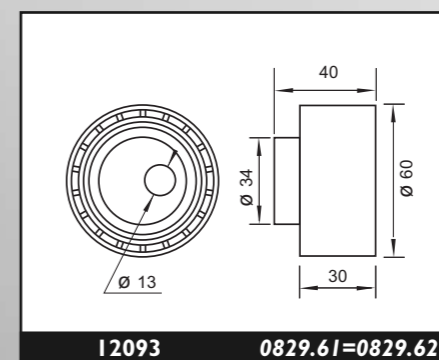
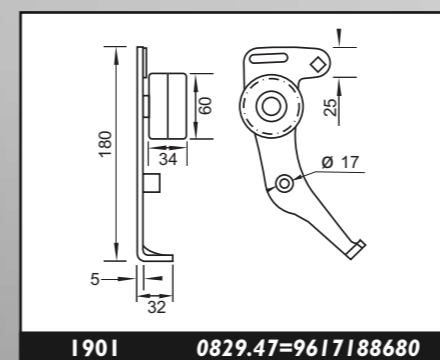
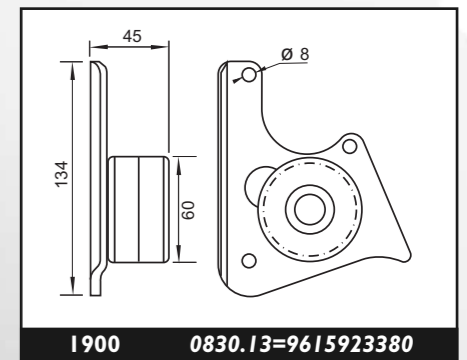
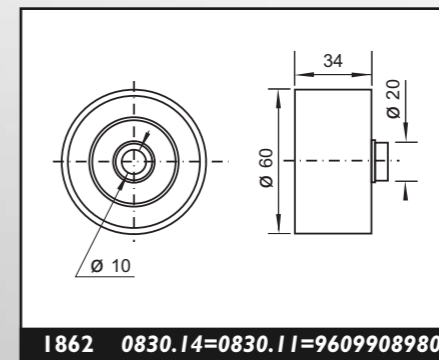
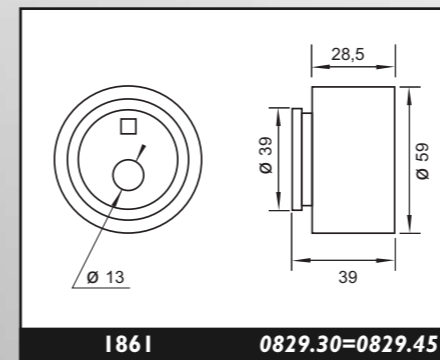
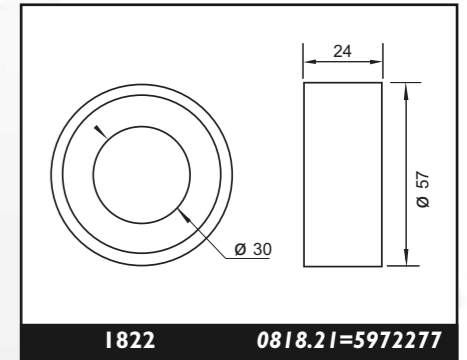

MODELO MODEL	AÑO YEAR	MOTOR ENGINE	CÓDIGO CODE		FIJO FIXED	MÓVIL MOBILE	NOTA NOTE
			EM euromotor®	EM euromotor®			

CITROEN BX

1.9	1905	N	XU9	07/86	02/93	1811	Desde motor From engine -5546
1.9 GTI	1905	N	XU9	07/86	02/93	1812	Hasta motor Up to engine -5545
1.9 GTI	1905	N	XU9	07/86	02/93	1811	Desde motor From engine -5546
1.9 GTI 16v	1905	N	XU9J4	09/87	12/93	1869	
1.8 D	1769	D	XUD7	10/85	09/93	1814	1813
1.8 TD	1769	D	XUD7	10/85	09/93	1814	1813
1.9 D	1905	D	XUD9	09/83	09/93	1814	1813

CITROEN C3

1.1	1124	N	TU1JP - HFX	02/02		12376	(60 cv)
1.4 16v	1360	N	TU3JP - KfV	02/02		12376	(73 cv)
1.6 16v	1587	N	TU5JP4 - NFU	02/02		1122	12451 (109 cv)
1.6 16v	1587	N	TU5JP4S	01/05		12594	12551
1.4 HDI	1398	D	DV4TD - 8HX	02/02		12377	12498 (72 cv)

CITROEN C4

1.6 16v	1587	N	TU5JP4S	01/07		12594	12551
2.0 16v	1997	N	EW10J4	01/08		92102	12334
2.0 HDI	1997	D	DW10TED	01/07		1119	1118

CITROEN C4 Coupe

2.0VTS	1997	N	EW10J4S 150HP	01/07		92102	12334
--------	------	---	---------------	-------	--	-------	-------

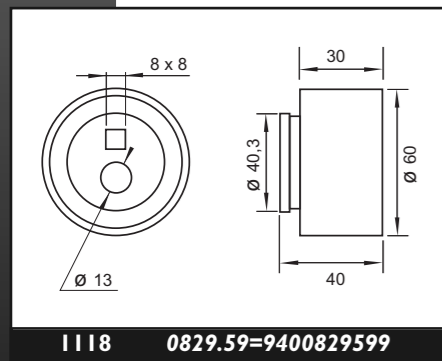

1118 0829.59=9400829599

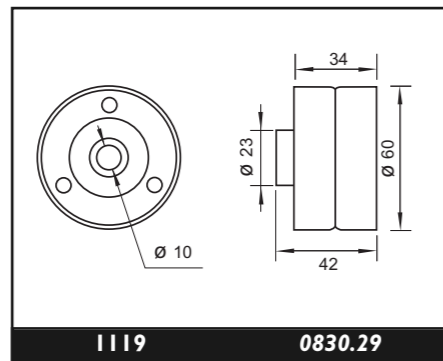

1119 0830.29

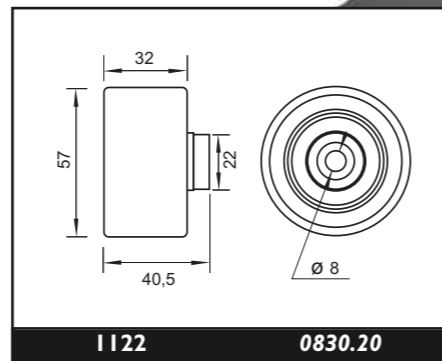

1122 0830.20

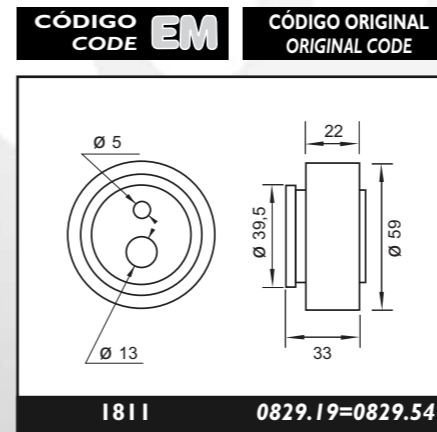

1811 0829.19=0829.54

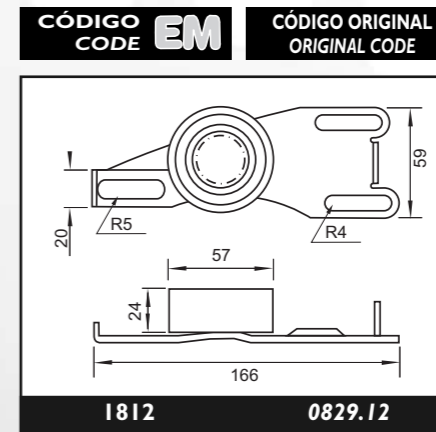

1812 0829.12

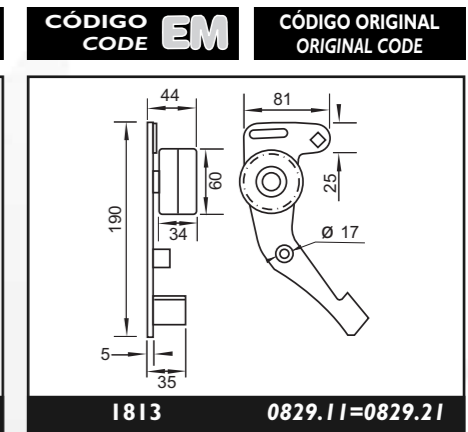

1813 0829.11=0829.21

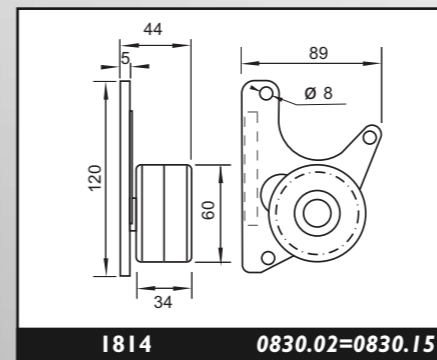

1814 0830.02=0830.15

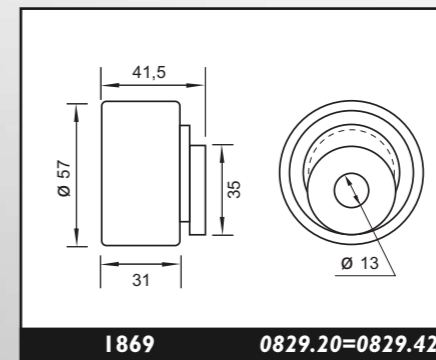

1869 0829.20=0829.42

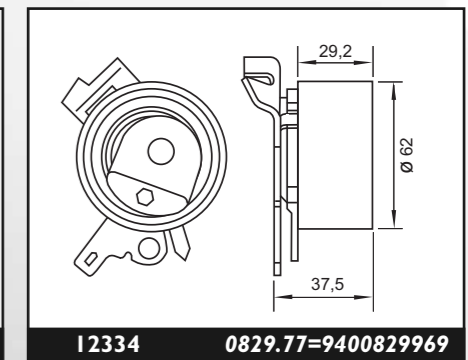

12334 0829.77=9400829969

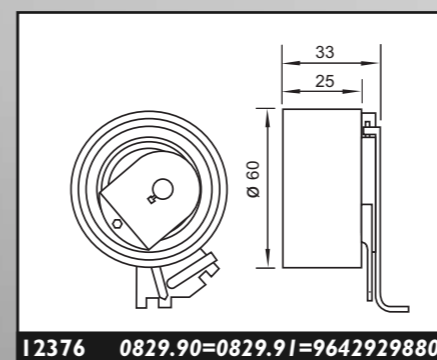

12376 0829.90=0829.91=9642929880

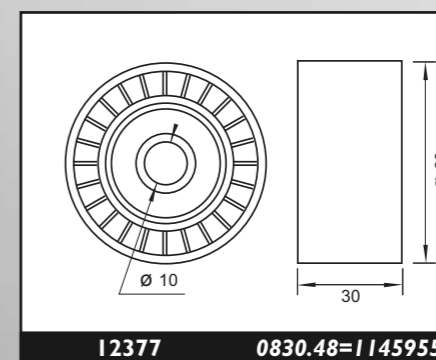

12377 0830.48=1145955

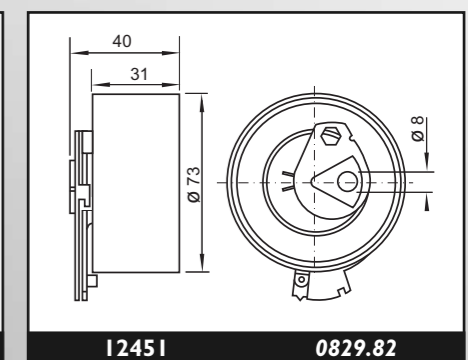

12451 0829.82

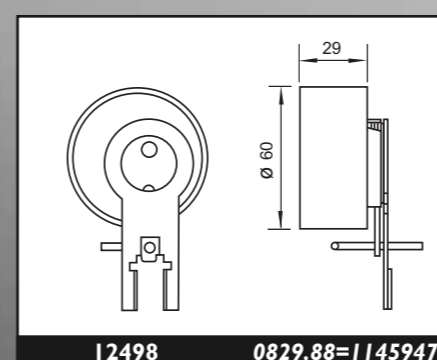

12498 0829.88=1145947

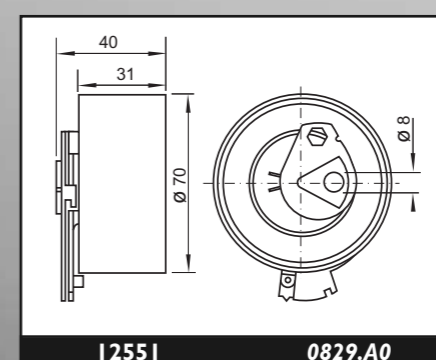

12551 0829.A0

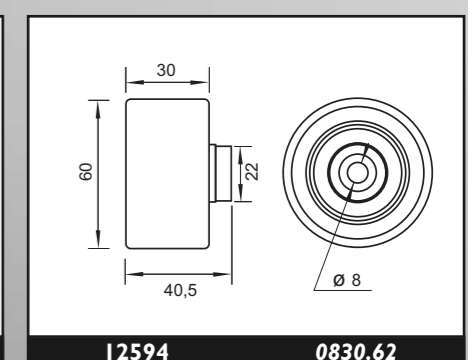

12594 0830.62

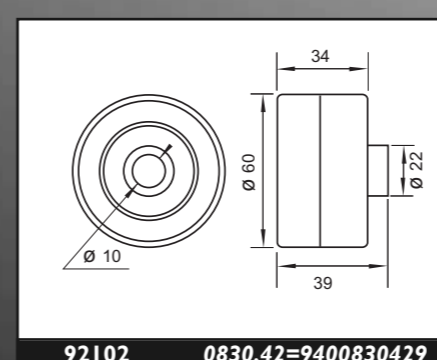

92102 0830.42=9400830429

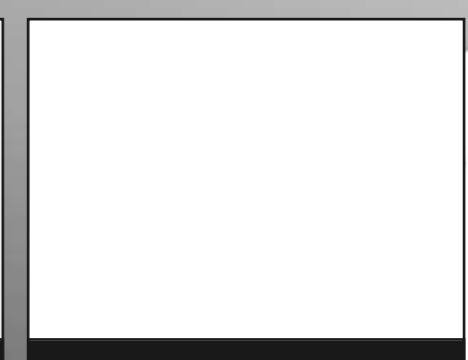
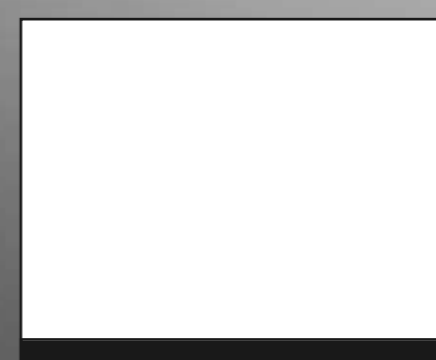

MODELO MODEL	COMB./FUEL	MOTOR ENGINE	AÑO YEAR		CÓDIGO CODE EM euromotor®		
			DESDE SINCE	HASTA TO	FIJO FIXED	MÓVIL MOBILE	NOTA NOTE

CITROEN C5

1.8 16v	1749	N	RFN - EW7J4	02/00		92102	12334	(136 cv)
2.0 16v	1997	N	RFN - EW10J4	02/00		92102	12334	(136 cv)
3.0V6 24v	2946	N	XFX - ES9J45	07/00		1170 1170 1171	12465	(207 cv)
2.0 HDI	1997	D	4HX	03/01		1119	1118	
2.0 HDI	1997	D	RHZ - DW10ATED	03/01		12094	12093	(109 cv)
2.0 HDI	1997	D	DW10BTED4	09/04		12507	12522	
2.2 HDI 16v	2179	D	DW12TED4	10/01		12094	12093	(109 cv)

CITROEN C8

2.0 16v	1997	N	EW10J4	07/02		92102	12334	
2.2 16v	2230	N	EW12J4	07/02		92102	12334	
3.0V6 24v	2946	N	XFX - ES9J45	07/00		1170 1170 1171	12465	(207 cv)
2.0 16v HDI	1997	D	DW10ATED4	08/01		12094 ó 1119	12093 ó 1118	
2.2 16v HDI	2179	D	DW12TED4	10/01		12094 ó 1119	12093 ó 1118	

CITROEN GS



GS		N	G	1975		1822		
----	--	---	---	------	--	------	--	--

CITROEN GSA

GSA		N	G	1975		1822		
-----	--	---	---	------	--	------	--	--

CITROEN SAXO

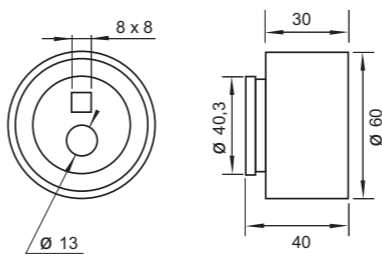
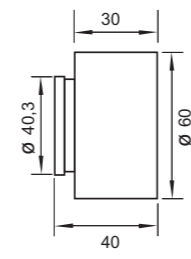
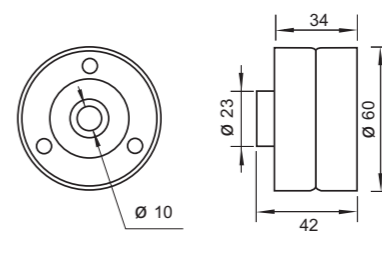
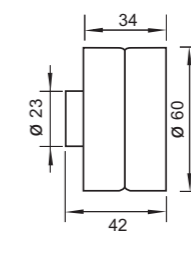
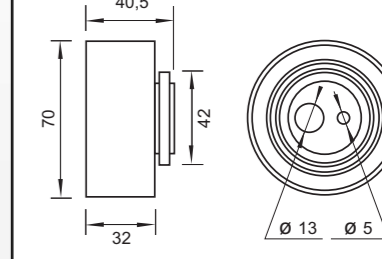
1.0	954	N	CDZ (TU9M)	05/96			1811	
1.1	1124	N	HDZ (TU1M)-HFX	05/96			1811	
1.4	1360	N	KFX (TU3JP)-KFW	05/96			1811	
1.6	1587	N	NFZ (TU5JP)	05/96			1811	
1.6VTS 16v	1587	N	NFX (TU5JP4)	06/96		1122	1121	

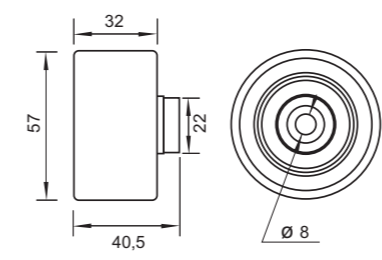
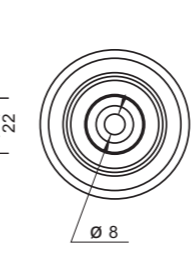
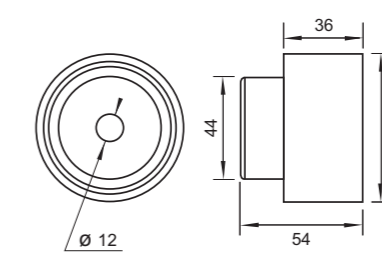
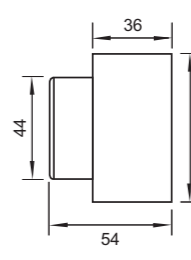
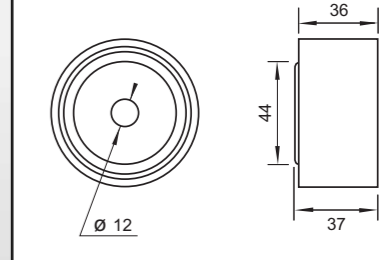
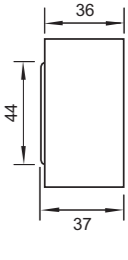
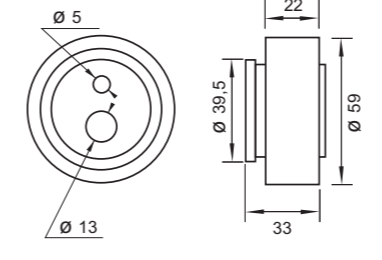
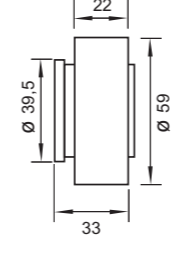
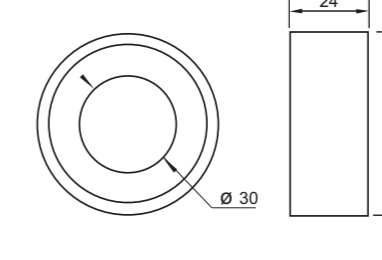
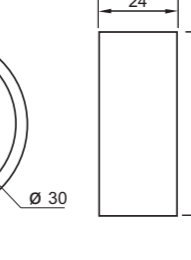
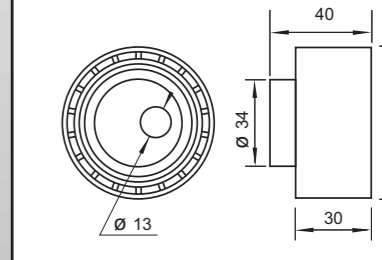
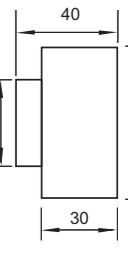
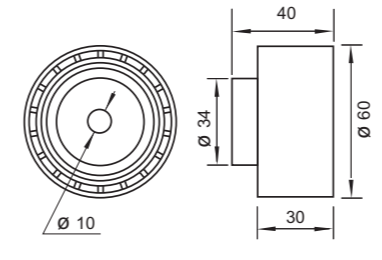
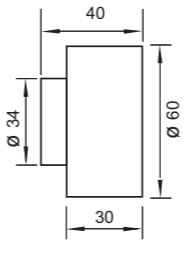
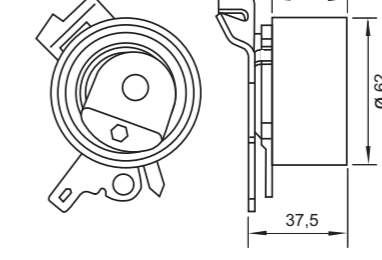
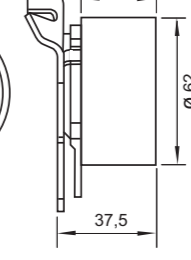
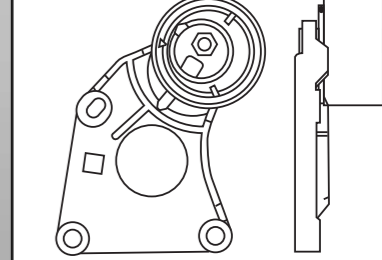
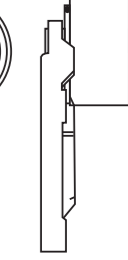
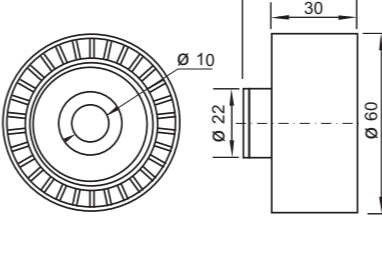
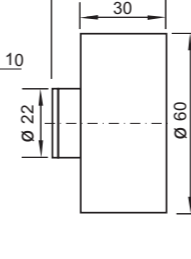
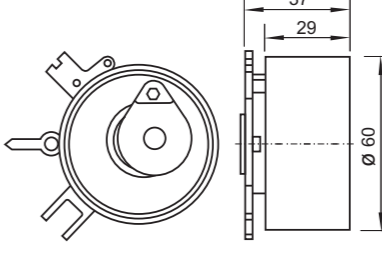
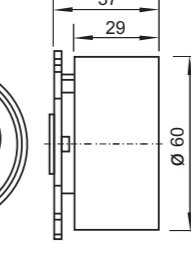
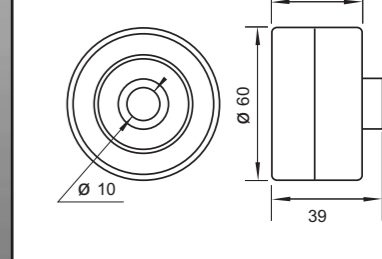
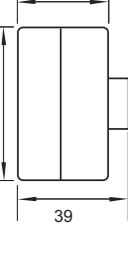
CÓDIGO CODE EM	CÓDIGO ORIGINAL ORIGINAL CODE	CÓDIGO CODE EM	CÓDIGO ORIGINAL ORIGINAL CODE	CÓDIGO CODE EM	CÓDIGO ORIGINAL ORIGINAL CODE
					
1118	0829.59=9400829599	1119	0830.29	1121	0829.49=1281.19
					
1122	0830.20	1170	0830.53=0830.58=9616660580	1171	0830.54=0830.59=9616660780
					
1811	0829.19=0829.54	1822	0818.21=5972277	12093	0829.61=0829.62
					
12094	0830.28=0830.30=0830.31	12334	0829.77=9400829969	12465	0823.08
					
12507	0830.51=9400829969	12522	0829.A4	92102	0830.42=9400830429

MODELO MODEL	COMB./ FUEL	MOTOR ENGINE	AÑO YEAR		CÓDIGO CODE EM euromotor®		
			DESDE SINCE	HASTA TO	FIJO FIXED	MÓVIL MOBILE	NOTA NOTE

CITROEN SAXO

1.5 D	1527	D	VJY - VJZ (TUD5)	09/96		1862	1861	
-------	------	---	------------------	-------	--	------	------	--

CITROEN XANTIA

1.6 i	1580	N	BFZ (XU5JP)	03/93	01/98		1811	
1.8 i	1761	N	LFX - LFZ (XU7JB/JP)	03/93			1811	
1.8 i 16v	1761	N	LFX (XU7JP4)	06/95		1862	1861	Hasta motor Up to engine P 8469
1.8 i 16v	1761	N	XU7JP4L3	06/95		1862	92100	
2.0 i	1998	N	RFX (XU10J2C)	03/93			1811	
2.0 i Turbo	1998	N	RGX (XU10J2TE)	06/95			1811	
2.0 i 16v	1998	N	PFV (XU10J4R)	06/95	01/98	1862	1943	
2.0 i 16v	1998	N	RFT - RFY (XU10J4 / Z)	06/94		1862	1869 12276	
3.0 i V6 24v	2946	N	ES9J4	01/97	01/98	1170 x2 1171	1161	
1.9 D	1905	D	XUD9 - XUD9TEY		06/93		1814	1813
1.9 D	1905	D	XUD9Y - XUD9DS	02/96			1900	1901
1.9 TD	1905	D	XUD9TF		06/93		1814	1813
1.9 TD	1905	D	XUD9BTF	07/93			1900	1901
2.0 HDI	1997	D	RHZ (DW10ATED)	02/99			12094	12093
2.1 TD	2088	D	P8C (XUD11BTE)	05/95	01/99		1862	1871
2.2 HDI	2179	D	DW12TED4	2001			12094	12093

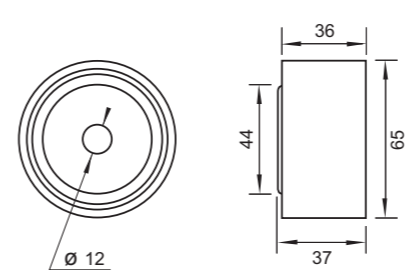
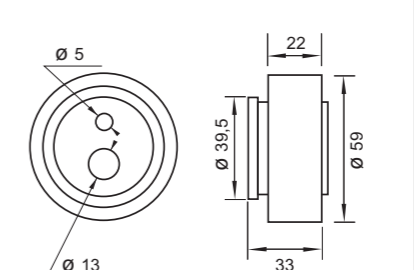
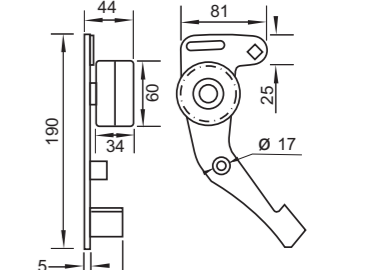
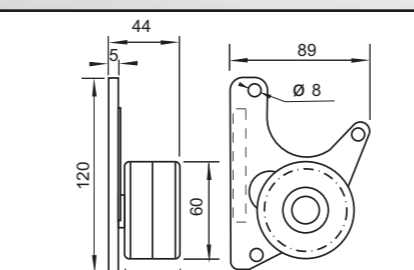
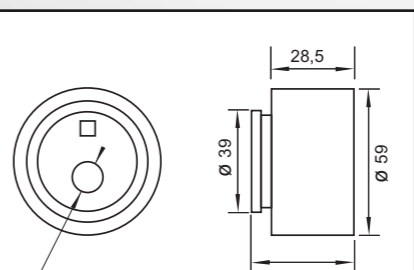
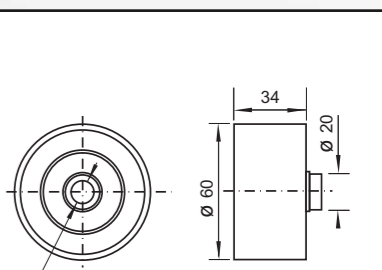
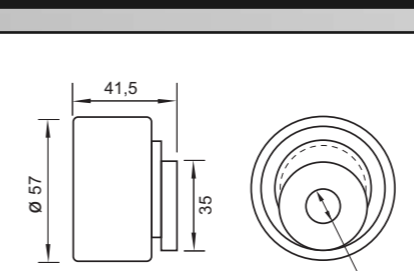
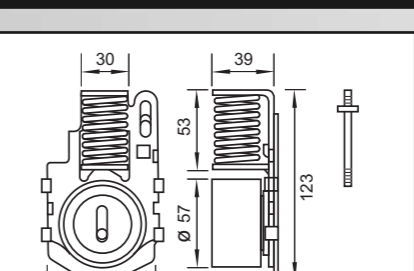
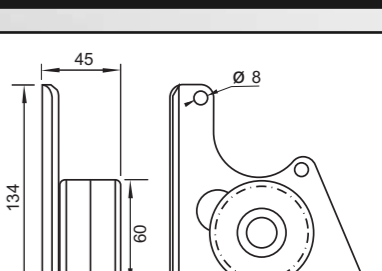
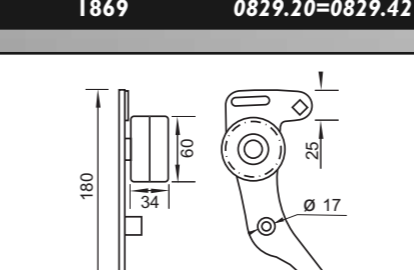
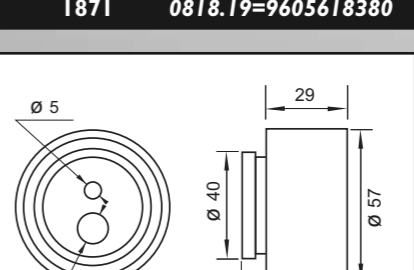
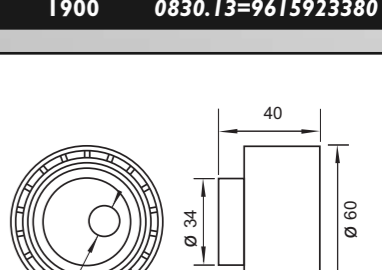
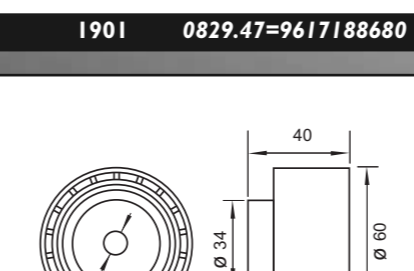
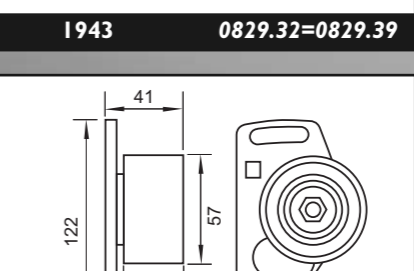
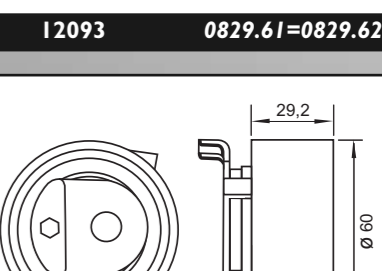
CÓDIGO CODE EM	CÓDIGO ORIGINAL ORIGINAL CODE	CÓDIGO CODE EM	CÓDIGO ORIGINAL ORIGINAL CODE	CÓDIGO CODE EM	CÓDIGO ORIGINAL ORIGINAL CODE
					
1171	0830.54=0830.59=9616660780	1811	0829.19=0829.54	1813	0829.11=0829.21
					
1814	0830.02=0830.15	1861	0829.30=0829.45	1862	0830.14=0830.11=9609908980
					
1869	0829.20=0829.42	1871	0818.19=9605618380	1900	0830.13=9615923380
					
1901	0829.47=9617188680	1943	0829.32=0829.39	12093	0829.61=0829.62
					
12094	0830.28=0830.30=0830.31	12276	0829.31=0829.46	92100	0829.69=9635336880

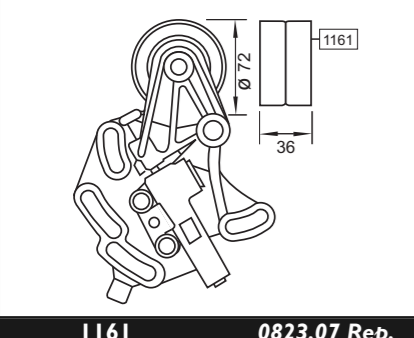

1161 0823.07 Rep.

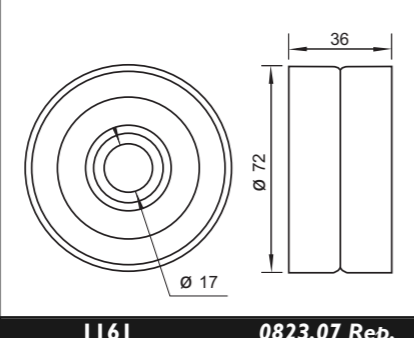

1161 0823.07 Rep.

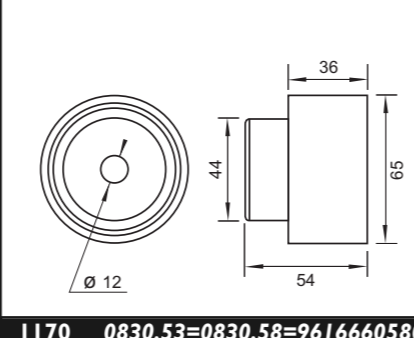

1170 0830.53=0830.58=9616660580

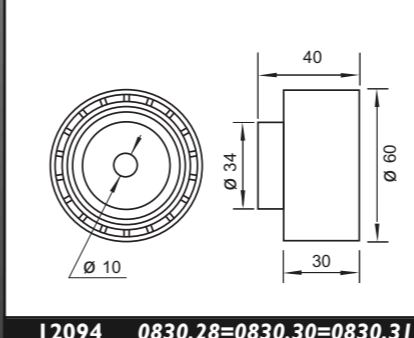

12094 0830.28=0830.30=0830.31

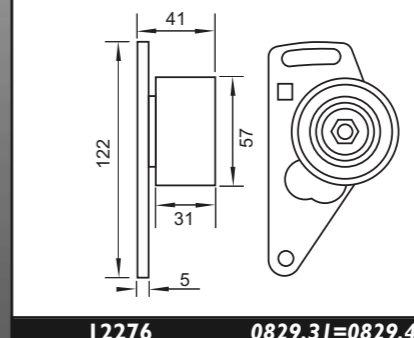

12276 0829.31=0829.46

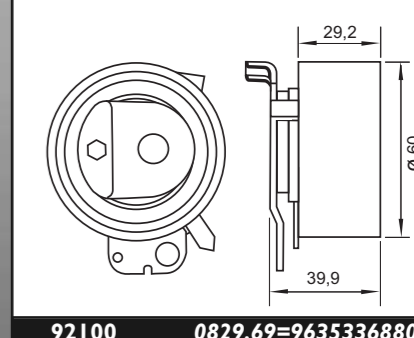

92100 0829.69=9635336880

MODELO MODEL	MOTOR ENGINE	AÑO YEAR		CÓDIGO CODE		
		DESDE SINCE	HASTA TO	FIJO FIXED	MÓVIL MOBILE	NOTA NOTE

CITROEN XM

2.0 i	1998	N	RFZ (XU10J2)	05/89	06/93	1862	12156	
2.0 i	1998	N	RFZ (XU10J2)	07/93	06/94	1862	1811	
2.0 i Turbo	1998	N	RGY (XU10J2TE/Z)	09/92	10/00	1862	1811	(142 cv - 147 cv)
2.0 i 16v	1998	N	RFV - XU10J4R	09/92	10/00	1862	1943	
2.0 i 16v	1998	N	RFT - RFY (XU10J4 / Z)	09/92	10/00	1862	1869 12276	
3.0V6	2946	N	ES9J4 - ZPJ / Z - ZPJ4 / Z	05/89		1170 x2 1171	1161	
3.0V6 24v	2963	N	ZPJ4 / Z	05/89		1170 x2 1171	1161	
2.1 D	2088	D	XUD11A/ATE/BTE	05/89	10/00	1862	1871	
2.1 TD	2088	D	XUD11A/ATE/BTE	05/89	10/00	1862	1871	
2.5 TD	2446	D	THY (DK5ATE)	05/94		1945	1944	

CITROEN XSARA

1.6 i	1587	N	NFZ (TU5JP)	04/97			1811	
1.6 16v	1587	N	TU5JP4	2000		1122	1121	
1.6 16v	1587	N	TU5JP4	08/00		1122	12451	
1.8 i	1761	N	XU7JP	04/97	11/00		1811	
2.0 16v	1998	N	XU10J4R	07/97	11/00	1862	1943	
1.9 D	1868	D	WJC (DW8)	07/98		12093	12094	

CÓDIGO CODE	EM	CÓDIGO ORIGINAL ORIGINAL CODE	CÓDIGO CODE	EM	CÓDIGO ORIGINAL ORIGINAL CODE	CÓDIGO CODE	EM	CÓDIGO ORIGINAL ORIGINAL CODE
1161		0823.07 Rep.	1170		0830.53=0830.58=9616660580	1171		0830.54=0830.59=9616660780
1811		0829.19=0829.54	1862		0830.14=0830.11=9609908980	1869		0829.20=0829.42
1871		0818.19=9605618380	1943		0829.32=0829.39	1944		0818.20
1945		0830.12 = 96094102	12093		0829.61=0829.62	12094		0830.28=0830.30=0830.31
12156		0829.22=0829.43	12276		0829.31=0829.46	12451		0829.82

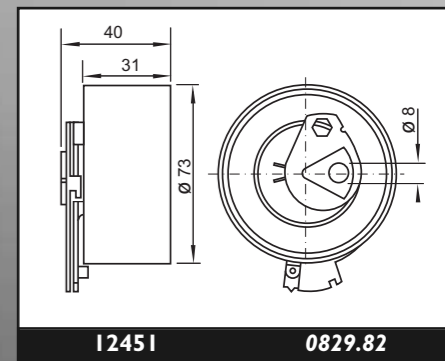
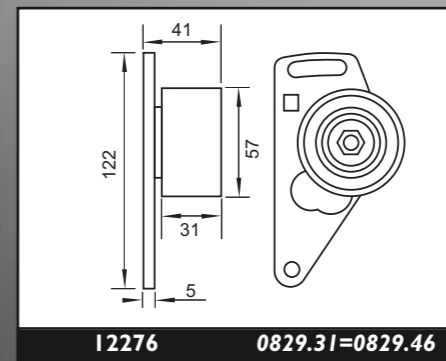
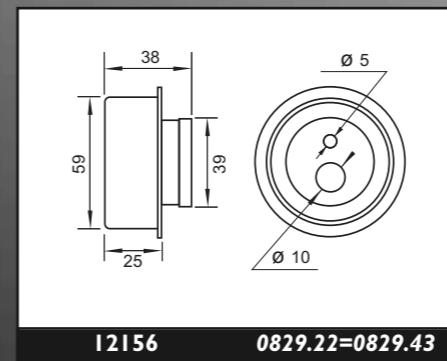
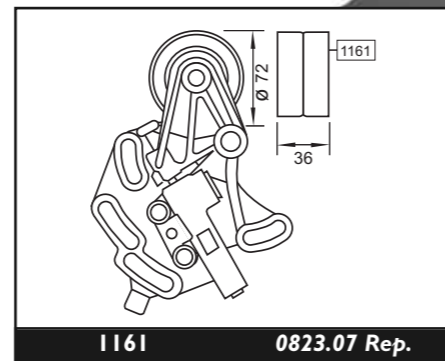
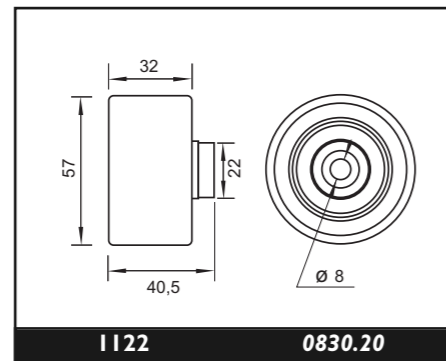
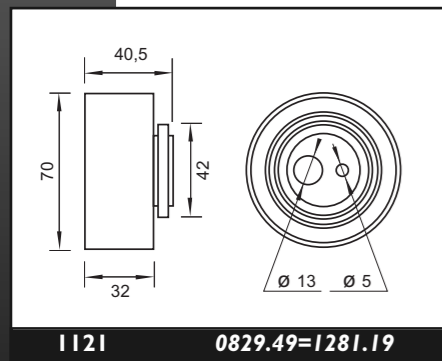

CITROEN

CITROEN

MODELO MODEL	AÑO YEAR	MOTOR ENGINE	CÓDIGO CODE		FIJO FIXED	MÓVIL MOBILE	NOTA NOTE
			EM euromotor®				

CITROEN XSARA

1.9 D	1905	D	XUD9	04/97		1900	1901	
1.9 TD	1905	D	XUD9	04/97		1900	1901	
2.0 HDI	1997	D	DW10	02/99		12093	12094	

CITROEN XSARA PICASSO

1.6 i 16v	1587	N	TU5JP4	06/00			1811	
1.8 i 16v	1761	N	LFY (XU7JP4) - EW7J4	02/00		1862	1943	
1.8 i 16v	1761	N	XU7JP4L4	04/97		1862	92100	P 8470
1.8 i 16v	1761	N	XU7JP4	04/97		1862	1943	-P 8469
1.8 i 16v	1761	N	XU7JP4	04/97		1862	92100	P 8470-
2.0 i 16v	1998	N	XU10J4RS	04/97	11/00	1862	92100	P 8470-
2.0 HDI	1997	D	DW10TD	06/00		12093	12094	

CITROEN ZX

1.4 i	1360	N	TU3	03/91	06/97		1811	
1.6 i	1580	N	XU5M - XU5JP	03/91	01/92		1812	
1.6 i	1580	N	XU5M - XU5JP	02/92	06/97		1811	
1.8 i	1750	N	LFZ (XU7JP)	07/92	06/97		1811	
1.8 i 16v	1761	N	LFY (XU7JP4L4)	01/96	06/97	1862	1943	
1.8 i 16v	1761	N	LFY (XU7JP4)	01/96		1862	92100	
1.9 i	1905	N	DKZ (XU9JA)	03/91	01/92		1812	- P 5545
1.9 i	1905	N	DKZ (XU9JA)	02/92	06/97		1811	P 5546-
2.0 i	1998	N	RFX (XU10J2C)	07/92	06/97		1811	
2.0 i 16v	1998	N	RFT - RFY (XU10J4/Z)	07/92	06/97	1862	1869 12276	(150 cv - 152 cv)
2.0 i 16v	1998	N	RFS (XU10J4RS)	05/96	06/97	1862	1943	(163 cv)
1.4 D	1360	D	TUD3	01/94	12/97	1862	1861	
1.6 D	1580	D	TUD5	01/94	12/97	1862	1861	

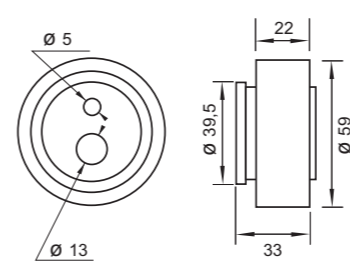
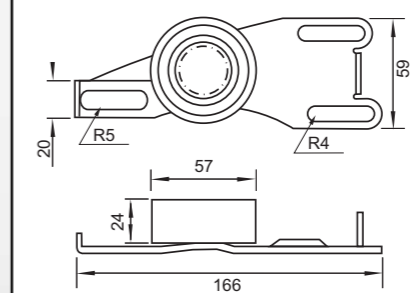
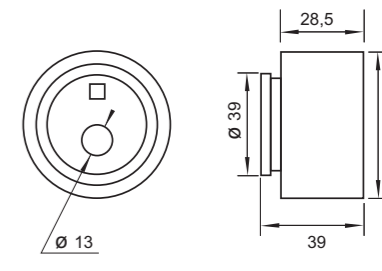
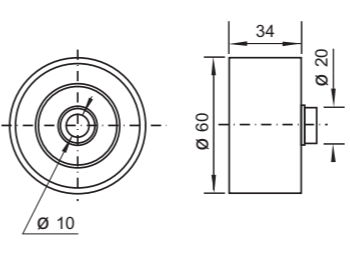
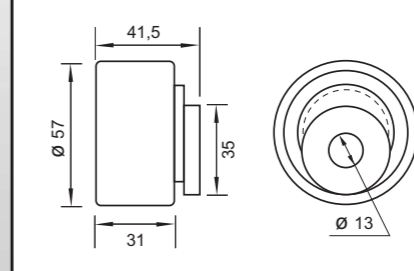
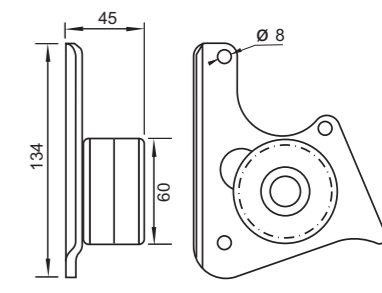
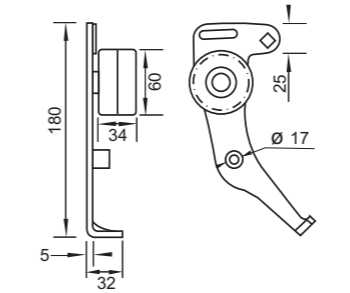
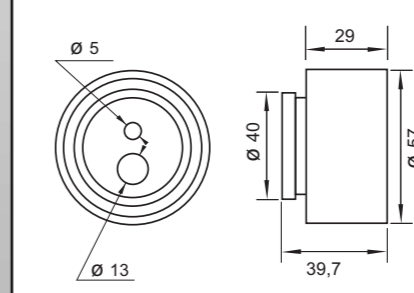
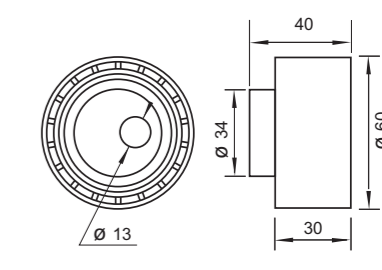
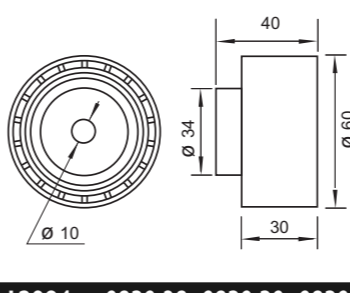
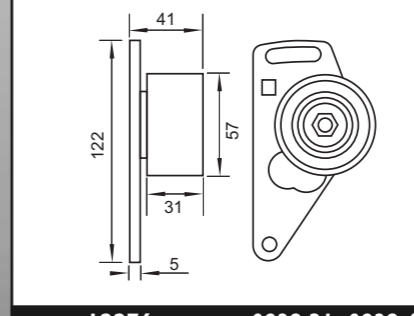
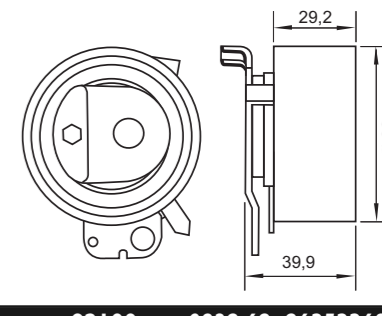
CÓDIGO CODE	EM	CÓDIGO ORIGINAL ORIGINAL CODE	CÓDIGO CODE	EM	CÓDIGO ORIGINAL ORIGINAL CODE	CÓDIGO CODE	EM	CÓDIGO ORIGINAL ORIGINAL CODE
	1811	0829.19=0829.54		1812	0829.12		1861	0829.30=0829.45
	1862	0830.14=0830.11=9609908980		1869	0829.20=0829.42		1900	0830.13=9615923380
	1901	0829.47=9617188680		1943	0829.32=0829.39		12093	0829.61=0829.62
	12094	0830.28=0830.30=0830.31		12276	0829.31=0829.46		92100	0829.69=9635336880

EM euromotor®

VERSION PDF 2010



Ø18

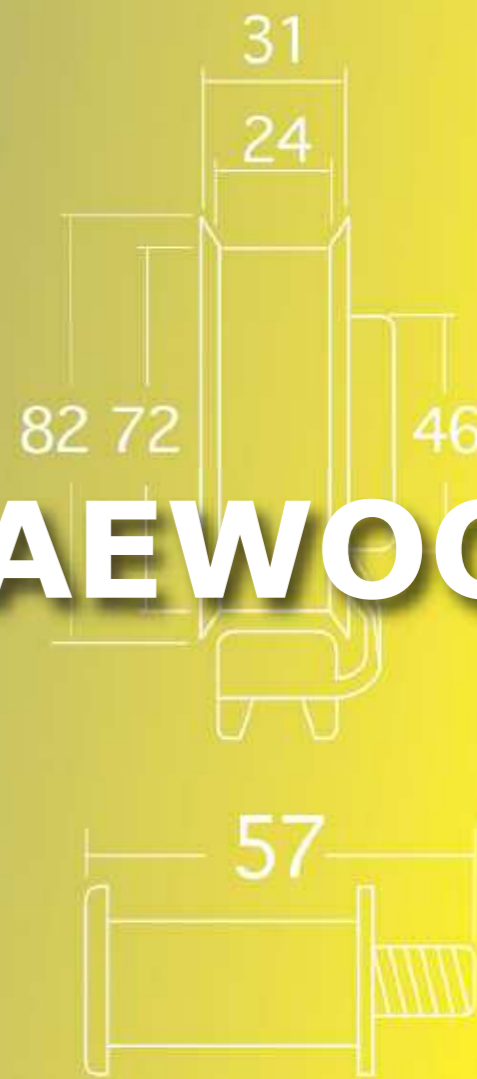

DAEWOO



MODELO MODEL	COMB./ FUEL	MOTOR ENGINE	AÑO YEAR		CÓDIGO CODE		
			DESDE SINCE	HASTA TO	FIJO FIXED	MÓVIL MOBILE	NOTA NOTE

DAEWOO NUBIRA

1.5 16v	1598	N	A16DMS	02/97		12234	12214	
1.6 16v	1498	N	A15MF	02/95		12234	12214	
1.6 16v	1598	N	A16DMS	02/97		12234	12214	
2.0	1998	N	KLAJ	05/97			1101	
2.0 16v	1998	N	X20SED	05/97		1906	1100	

DAEWOO RACER

2.0 16v	1988	N	KLAC	09/00		1906	1100	
---------	------	---	------	-------	--	------	------	--

DAEWOO TACUMA

2.0 16v	1988	N		09/00		1906	1100	
---------	------	---	--	-------	--	------	------	--

DAEWOO TICO

800	796	N	F8C	11/93	03/97		12329	
-----	-----	---	-----	-------	-------	--	-------	--

CÓDIGO CODE	EM	CÓDIGO ORIGINAL ORIGINAL CODE	CÓDIGO CODE	EM	CÓDIGO ORIGINAL ORIGINAL CODE	CÓDIGO CODE	EM	CÓDIGO ORIGINAL ORIGINAL CODE
1100		90153125=9157004	1101		9158003=636727=636746=636738	1906		90530126
1907		636416	12214		5094008601=96350550	12234		96103222
12329		12810-81401						

EM euromotor®

VERSION PDF 2010



$\varnothing 18$

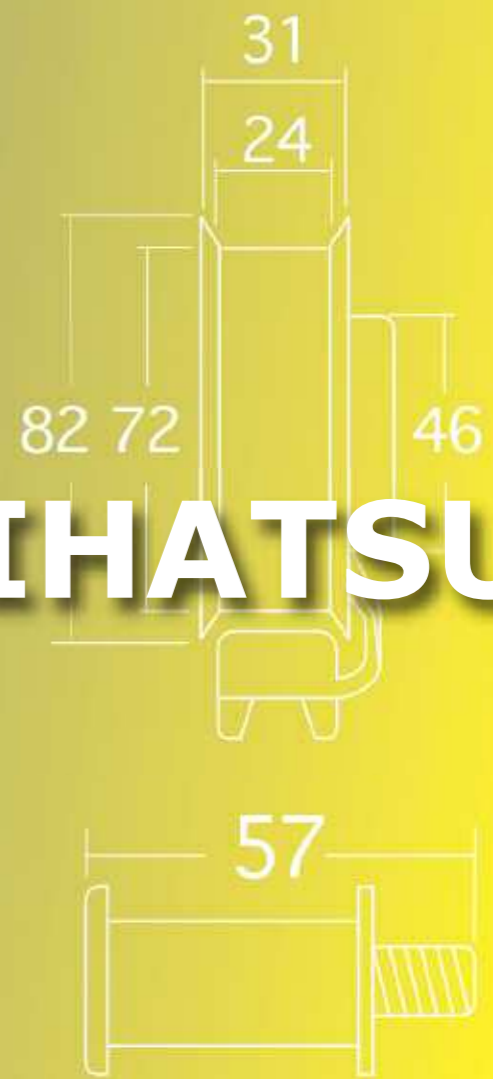

DAIHATSU



MODELO MODEL	COMB./FUEL	MOTOR ENGINE	AÑO YEAR		CÓDIGO CODE EM euromotor®		
			DESDE SINCE	HASTA TO	FIJO FIXED	MÓVIL MOBILE	NOTA NOTE

DAIHATSU APPLAUSE

1.6 16v	1590	N		08/89			12233
---------	------	---	--	-------	--	--	-------

DAIHATSU CHARADE

1.0	993	N	CB23/90/61	01/83	12/92		12310
Turbo	993	N	CB23/90/61	04/87	12/92		12232
Turbo	993	N	CB23/90/61	04/87	12/92		12310
Gti	993	N	CB23/90/61	04/87	12/92		12232
Gti	993	N	CB23/90/61	04/87	12/92		12310
1.3	1296	N	HCE	06/88	12/92		12232
1.3	1296	N	HC	01/93			12233
1.3 16v	1296	N	HC	01/93			12233
1.5 16v	1499	N	HEE	01/97			12233
1.6 Gti	1590	N	HD-E	03/93			12233

DAIHATSU CUORE

0.9	846	N	EB	06/85	04/99		12494
0.9	846	N	ED10/10K - ED20	05/89	11/96		12495
0.9	846	N	EF-EL	12/96	10/98		12495
1.0 12v	989	N	EDJE	11/98			12302

DAIHATSU DOMINO

0.5	547	N	EB	10/80	07/96		12494
0.9	846	N	ED10	09/85	04/89		12496

DAIHATSU FERROZA

1.6	1590	N	HDC - HDE	10/88			12233
-----	------	---	-----------	-------	--	--	-------

DAIHATSU HIJET

1.0	993	N	CB	06/86	12/89		12496
1.0	993	N	CB41 - CB42	01/90			12232

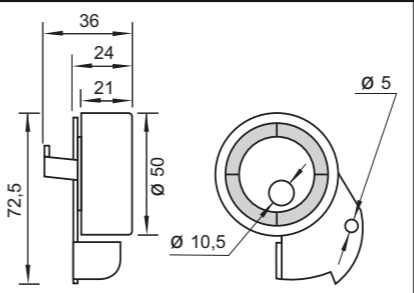
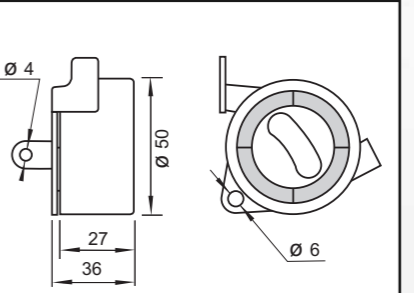
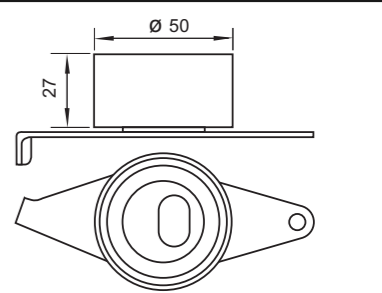
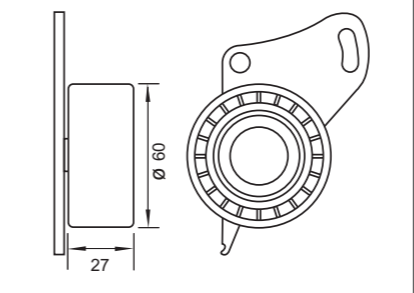
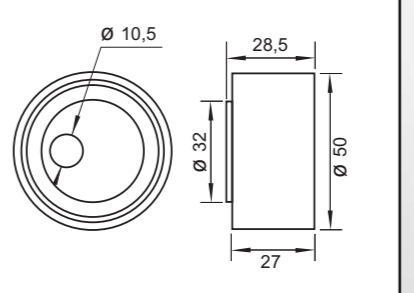
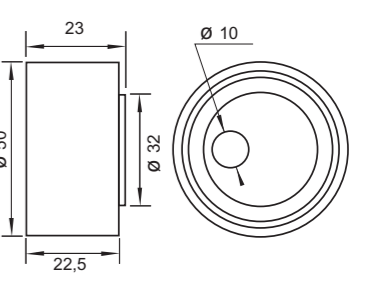
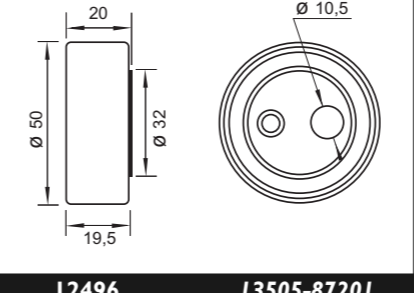
CÓDIGO CODE EM	CÓDIGO ORIGINAL ORIGINAL CODE	CÓDIGO CODE EM	CÓDIGO ORIGINAL ORIGINAL CODE	CÓDIGO CODE EM	CÓDIGO ORIGINAL ORIGINAL CODE
					
12232	13505-87702	12233	13505-87102	12302	13505-97201
					
12310	13505-87701	12494	13505-87205	12495	13505-87203
					
12496	13505-87201				

MODELO MODEL	COMB. / FUEL	MOTOR ENGINE	AÑO YEAR		CÓDIGO CODE EM euromotor®		
			DESDE SINCE	HASTA TO	FIJO FIXED	MÓVIL MOBILE	NOTA NOTE

DAIHATSU ROCKY

1.6	1590	N	HDE	07/90	05/92		12233	
2.8 D	2798	D	DL - DL51 - DL52 DL50	02/85	12/87	12497	12508	
2.8 TD	2798	D	DL50 - DL52	01/88		12497	12508	

DAIHATSU SIRION

1.0i 12v	989	N	EJ	04/98			12302	
1.3i 16v	1298	N		05/99			12233	

DAIHATSU TERIOS

1.3i 16v	1296	N		10/97			12233	
----------	------	---	--	-------	--	--	-------	--

DAIHATSU YRV

1.0 12v	989	N	EDJEJ	10/00			12302	
1.3 16v	989	N		10/00			12232	

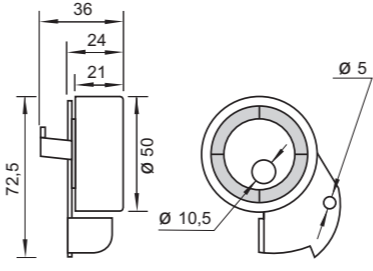
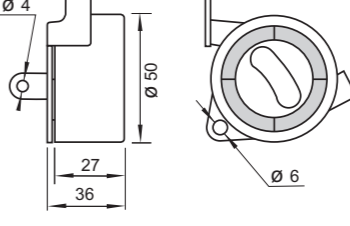
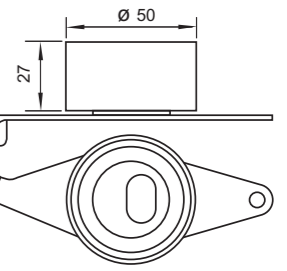
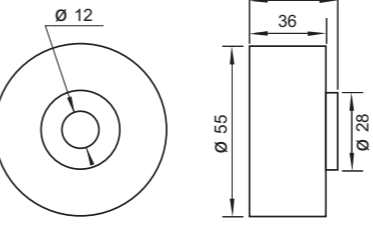
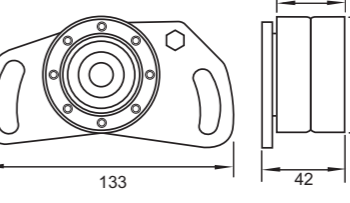
CÓDIGO CODE EM	CÓDIGO ORIGINAL ORIGINAL CODE	CÓDIGO CODE EM	CÓDIGO ORIGINAL ORIGINAL CODE	CÓDIGO CODE EM	CÓDIGO ORIGINAL ORIGINAL CODE
					
12232	13505-87702	12233	13505-87102	12302	13505-97201
					
12497	13505-87301	12508	13505-87303		

EM euromotor®

VERSION PDF 2010

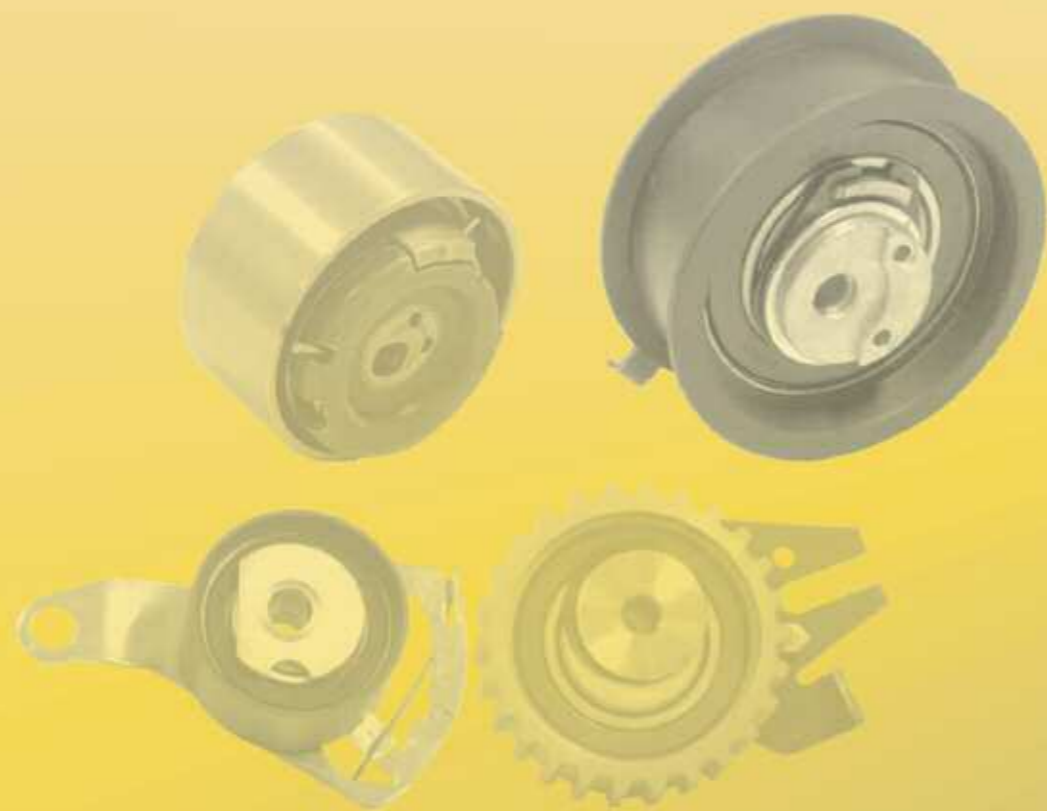

$\varnothing 18$

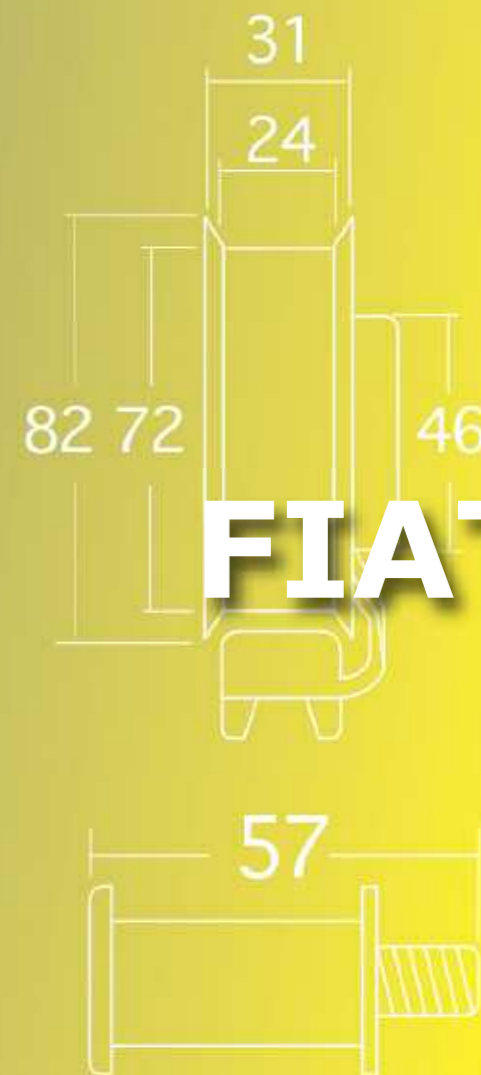

FIAT



MODELO MODEL	COMB./FUEL	MOTOR ENGINE	AÑO YEAR		CÓDIGO CODE EM euromotor®		
			DESDE SINCE	HASTA TO	FIJO FIXED	MÓVIL MOBILE	NOTA NOTE

FIAT 124

1.3	1290	N	...A100 - ...B000			1852		
1.6	1592	N	I32AC000	01/69	12/75	12500		
2.0 SPORT	1585	N				1852		

FIAT 125

1.3	1290	N	...A100 - ...B000			1852		
1.6	1608	N	I25A - I25B	07/67	03/74	12500		
2.0	1980	N				1852		

FIAT 127



1.3 D	1301	D	I46B1000	04/81		1840	1825	
-------	------	---	----------	-------	--	------	------	--

FIAT 128

1.1	1095	N	I28A			1851		
1.1	1095	N				1851		
1.3 Europa y Super Europa	1290	N				1855		
1.3	1290	N				12500		
1.5	1490	N				1872		

FIAT 131

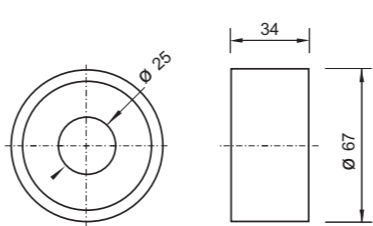
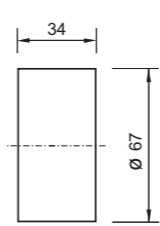
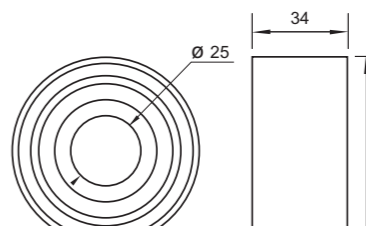
1.3	1297	N		01/78	12/80	1855		
1.3	1297	N				12500		
1.4	1367	N	I31C000-I31C1000	11/80	01/84	12500		
1.6	1585	N	I31A1000-I31B1000	02/84	04/85	1852		
1.6	1585	N	I31C2000-I31C3000			12500		
1.6	1585	N				1872		
2.0	1995	N		01/76	12/84	1872		
2.5 D	2445	D	8144.61	06/78	12/84	1816	1821	

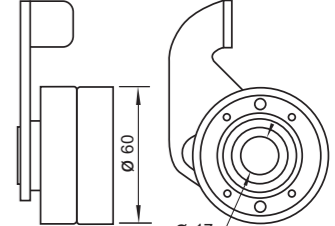
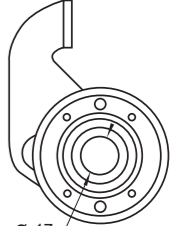
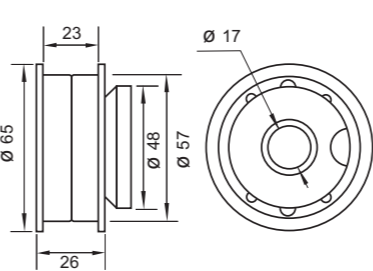
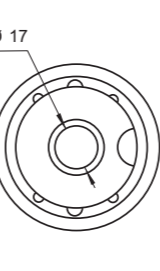
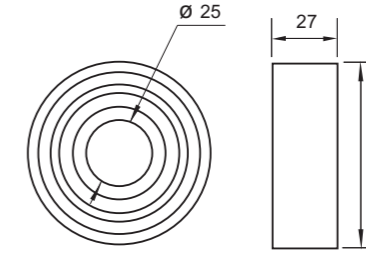
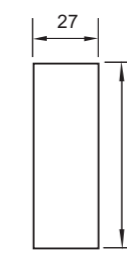
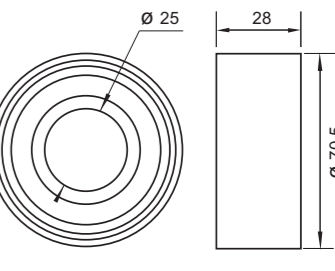
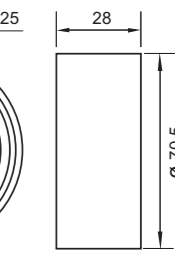
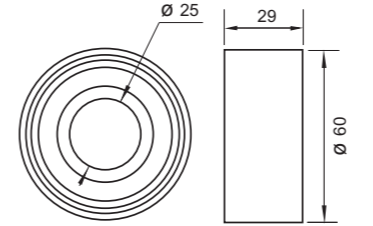
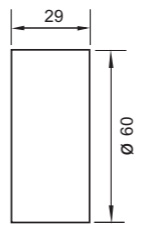
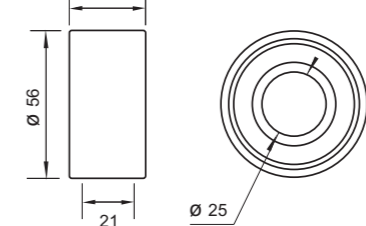
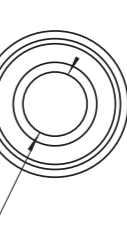
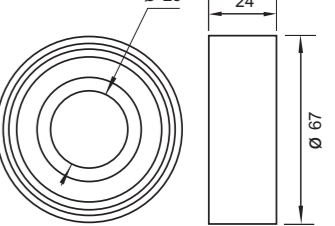
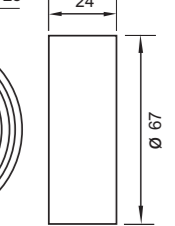
CÓDIGO CODE EM	CÓDIGO ORIGINAL ORIGINAL CODE	CÓDIGO CODE EM	CÓDIGO ORIGINAL ORIGINAL CODE	CÓDIGO CODE EM	CÓDIGO ORIGINAL ORIGINAL CODE
 1816	 4740846	 1821	 4740847	 1825	 4438894
 1840	 5952181	 1851	 4320893=4277048	 1852	 4178014=4443446
 1855	 4320893	 1872	 4386575	 12500	 4178016=4443703

MODELO MODEL	COMB./ FUEL	MOTOR ENGINE	AÑO YEAR		CÓDIGO CODE EM euromotor®		
			DESDE SINCE	HASTA TO	FIJO FIXED	MÓVIL MOBILE	NOTA NOTE

FIAT 132

1.6	1592	N		01/74	12/75	1872		
2.0	1995	N		05/77	12/82	1872		
2.5 D	2445	D	8144.61	07/78	07/82	1816	1821	

FIAT 147

1.0	995	N		03/83		1822		Correa/ Belt 118 dientes/ teeth
1.1	1095	N		01/85		1851		Correa/ Belt 116 dientes/ teeth
1.3	1290	N		08/85		1855		
1.4	1372	N	160A1000	07/88		1822		
1.3 D	1302	D	146B1000	05/86		1840	1825	

FIAT ARGENTA

1.6	1585	N		04/81	12/85	12500		
1.6	1585	N		01/83	12/85	1852		
1.6	1585	N				1872		
2.0	1995	N		01/81	12/83	1852		Correa/ Belt 123 dientes/ teeth
2.0	1995	N		01/84	07/86	1872		Correa/ Belt 148 dientes/ teeth
2.5 D	2445	D	8144.61	06/81	08/85	1816	1821	
2.5 TD	2445	D	8144.61	07/83	08/85	1816	1821	

FIAT BARCHETTA

1.8 16v	1747	N	183A1000	04/95	05/98	12393	12090	
1.8 16v	1747	N	183A1000	06/98	02/03	12393	12354	

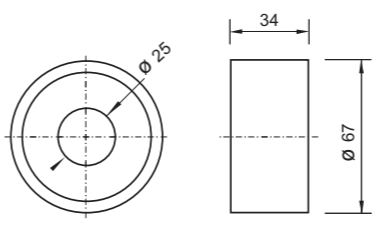
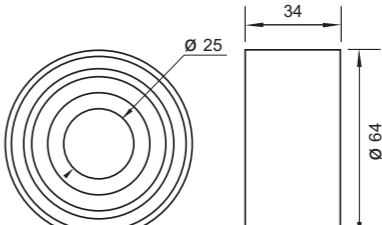
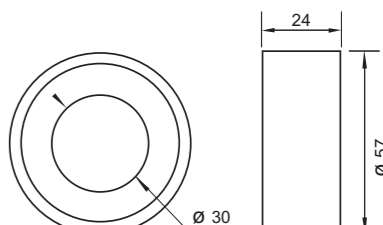
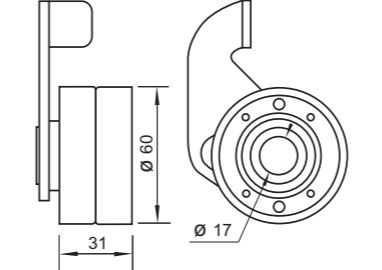
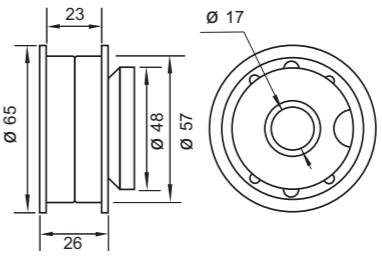
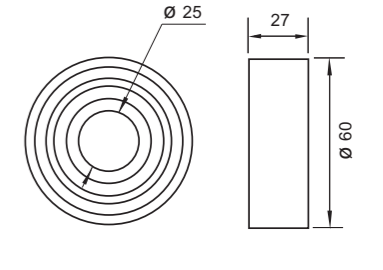
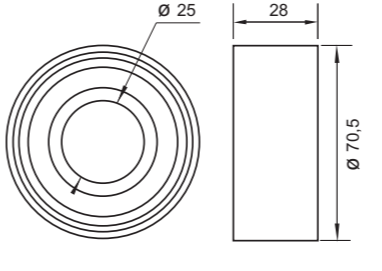
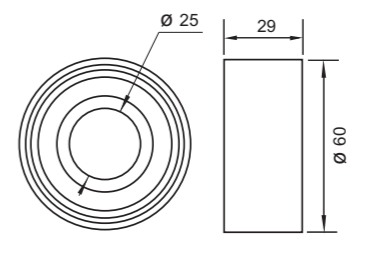
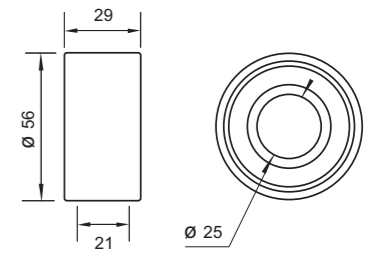
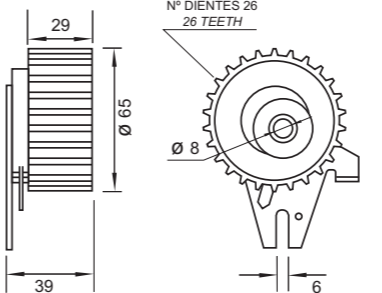
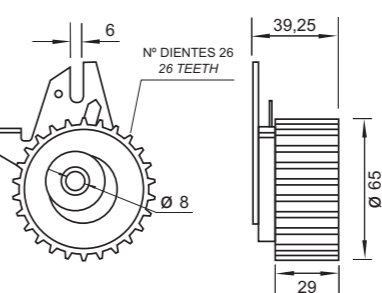
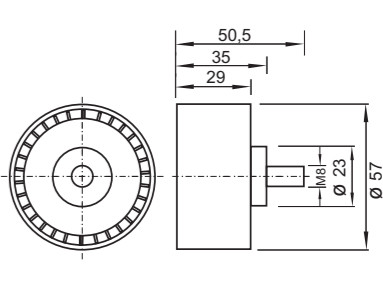
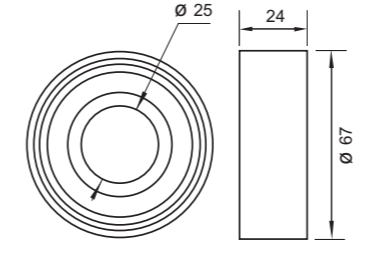
CÓDIGO CODE EM	CÓDIGO ORIGINAL ORIGINAL CODE	CÓDIGO CODE EM	CÓDIGO ORIGINAL ORIGINAL CODE	CÓDIGO CODE EM	CÓDIGO ORIGINAL ORIGINAL CODE
	1816		1821		1822
4740846	4740847	5972277			
	1825		1840		1851
4438894	4438894	5952181	4320893=4277048		
	1852		1855		1872
4178014=4443446	4178014=4443446	4320893	4320893	4386575	4386575
	12090		12354		12393
55192323 = 60813592	55192323 = 60813592	60621380=60652477=60814462	60621380=60652477=60814462	60652126 = 60671573	60652126 = 60671573
	12500				
4178016=4443703	4178016=4443703				

MODELO MODEL	MOTOR ENGINE	AÑO YEAR	CÓDIGO CODE			NOTA NOTE
			DESDE SINCE	HASTA TO	EM euromotor®	

FIAT BRAVA - BRAVO

1.2 16v	1242	N	182B2000	12/98		12155		
1.6 16v	1581	N	182A4000 182A6000	10/95	12/96	1951	12091	
1.6 16v	1747	N	182A2000	10/95	08/98	12393	12090	Hasta motor <i>Up to engine</i> 1615594
1.8 16v	1747	N	182A2000	09/98		12393	12090 12354	Desde motor <i>From engine</i> 1615595
2.0 HGT	1988	N	182B7000	10/95			1113	154 cv
1.9 D	1930	D	160A7000	10/95		1889	1835	
1.9 TD	1910	D	182A8000 182A7000	03/96		1950	1115	(75cv - 100cv)
1.9 JTD	1910	D	182B4000	12/98		1950	1115	(100cv - 105cv)

FIAT CAMPAGNOLA

2.5 D	2445	D	8144.61 Sofim	06/74	10/89	1816	1821	
-------	------	---	---------------	-------	-------	------	------	--

FIAT CINQUECENTO

1.1	1108	N	176B2000	10/94		1822		
-----	------	---	----------	-------	--	------	--	--

FIAT COUPE

1.8 16v	1747	N	183A1000	03/96	07/98	12393	12090	
1.8 16v	1747	N	183A1000	08/98		12393	12354	Desde motor <i>From engine</i> 1070426
2.0 20v - Turbo	1998	N	182A1000-175A3000 182B3000	08/96			1113	(147 cv- 154 cv)

FIAT DOBLO

1.2	1242	N	223A5.000-	11/00	03/03	1822		(65 cv)
1.6 16v	1596	N	182B6.000-	10/01	03/03	1951	12091	
1.9 D	1910	D	223A6.000	11/00	03/03	1951	1115	(63 cv)
1.9 JTD	1910	D	182B9.000	10/01	03/03	1951	1115	

CÓDIGO CODE	EM	CÓDIGO ORIGINAL ORIGINAL CODE	CÓDIGO CODE	EM	CÓDIGO ORIGINAL ORIGINAL CODE	CÓDIGO CODE	EM	CÓDIGO ORIGINAL ORIGINAL CODE
1113		7772961	1115		60596372 = 60812622	1816		4740846
1821		4740847	1822		5972277	1835		7596728=7596877
1889		5970621=7596727=7596876=60808692	1950		71736493 = 7763644	1951		46400054=46554826
12090		55192323 = 60813592	12091		46416489	12155		46403679=46817666
12354		60621380=60652477=60814462	12393		60652126 = 60671573			

MODELO MODEL	COMB./ FUEL	MOTOR ENGINE	AÑO YEAR		CÓDIGO CODE EM euromotor®		
			DESDE SINCE	HASTA TO	FIJO FIXED	MÓVIL MOBILE	NOTA NOTE

FIAT DUNA



I.3	I301	N	I46A5000	01/87	12/91	1818	Correa/ Belt 116 dientes/ teeth
I.3 mpi		N	I76B900			12455 ó 12155	Man.Tens. Aut.Tens.
I.3 Fire	I242	N	I83A500			12155	
I.4	I372	N	I60A1000			12027	1822
I.5	I478	N					1872
I.6	I580	N	I60A2000			12027	1822
I.3 D	I302	D	I46B1000			1840	1825
I.7 D	I698	D	I49B3000	01/87	12/91	1820	1819

FIAT IDEA

I.4 Fire	I368	N		07/07		12155	
I.8	I796	N	C18NZ	09/05		1101	

FIAT MAREA

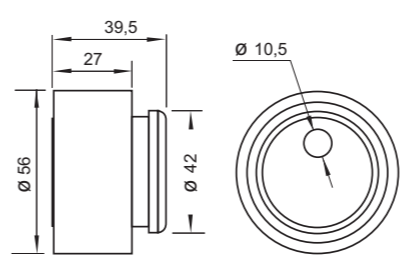
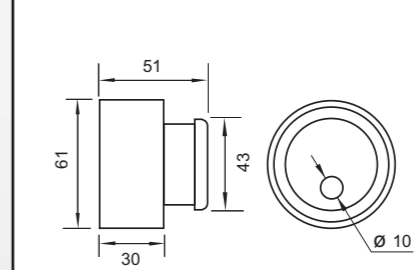
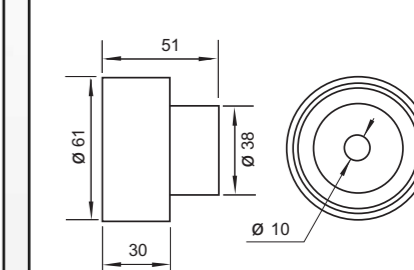
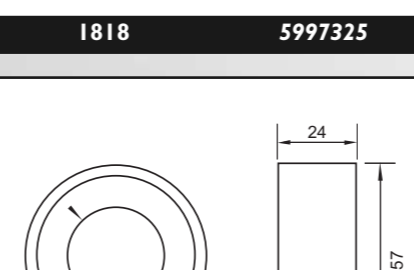
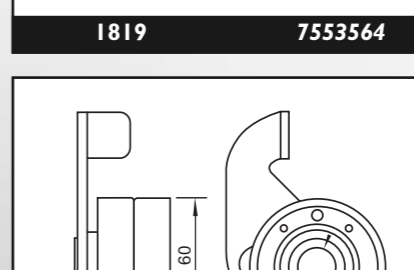
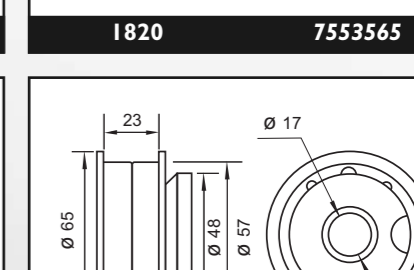
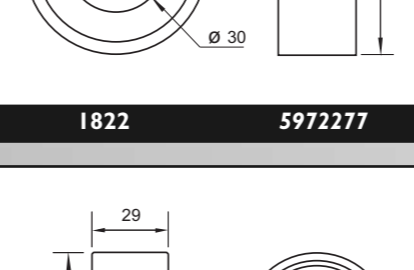
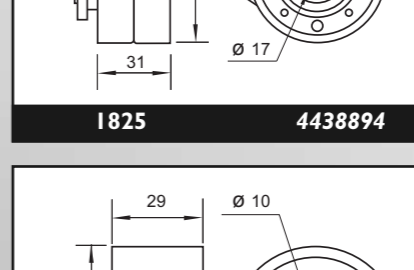
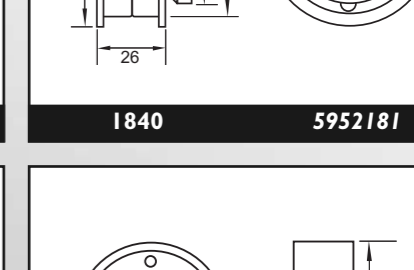
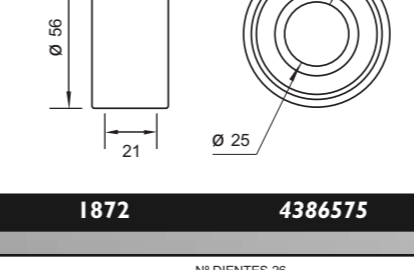
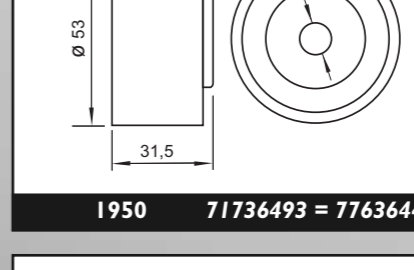
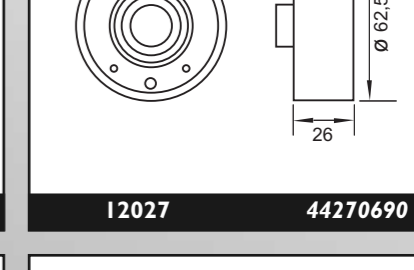
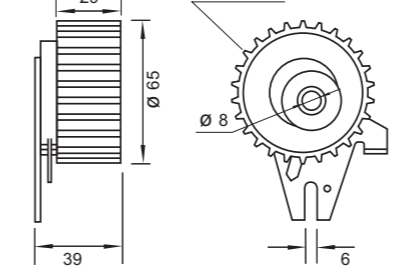
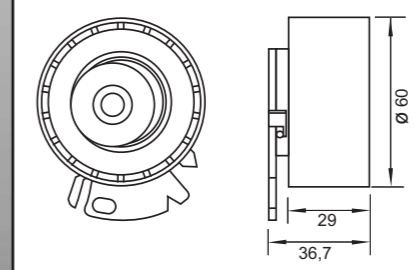
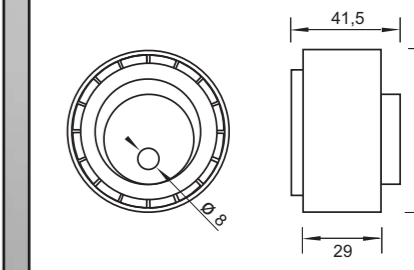
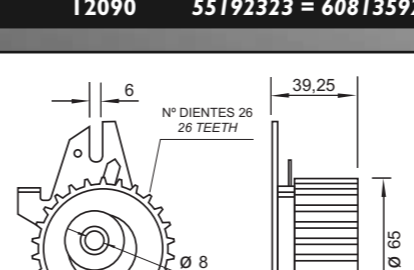
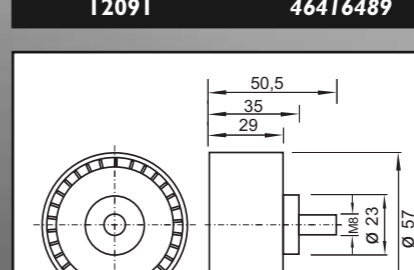
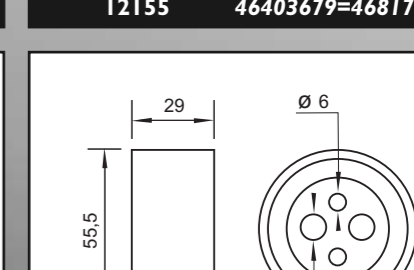
I.6 16v	I581	N	I82A4000	10/95		1950	12091	(103 cv)
I.6 16v	I747	N	I82A2000	09/96	12/98	12393	12090	
I.8 16v	I747	N	I82A2000	01/98		12393	12354	
2.0 20v	I998	N	I82B1000 - I82B7000	09/96		1950	1113	(150 cv - 155 cv) 5 Cil.
I.9 TD	I910	D	I82A8000 - I82A7000	09/96		1950	1115	(75 cv - 100 cv)
I.9 JTD	I910	D	I82B4000 -	04/99		1950	1115	(105 cv - 110 cv)

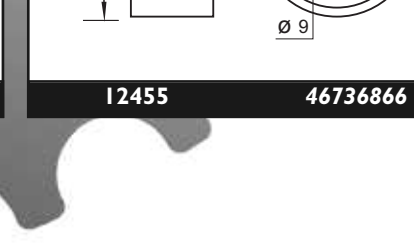
CÓDIGO CODE EM	CÓDIGO ORIGINAL ORIGINAL CODE	CÓDIGO CODE EM	CÓDIGO ORIGINAL ORIGINAL CODE	CÓDIGO CODE EM	CÓDIGO ORIGINAL ORIGINAL CODE
	1818		5997325		1819
	1819		7553564		1820
	1822		5972277		1825
	1825		4438894		1840
	1840		5952181		1872
	1872		4386575		1950
	1950		71736493 = 7763644		12027
	12027		44270690		12090
	12090		55192323 = 60813592		12091
	12091		46416489		12155
	12155		46403679=46817666		12354
	12354		60621380=60652477=60814462		12393
	12393		60652126 = 60671573		12455
	12455		46736866		

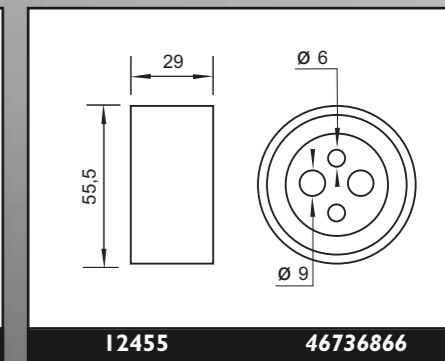
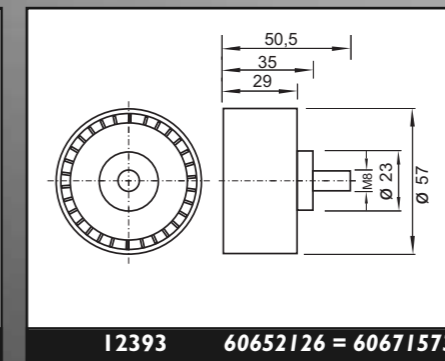
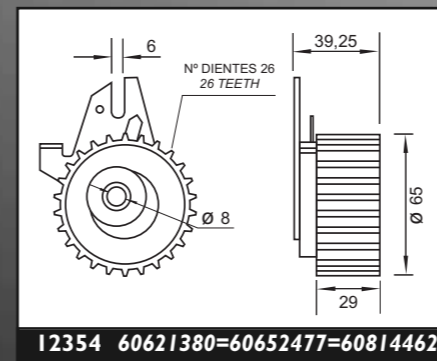
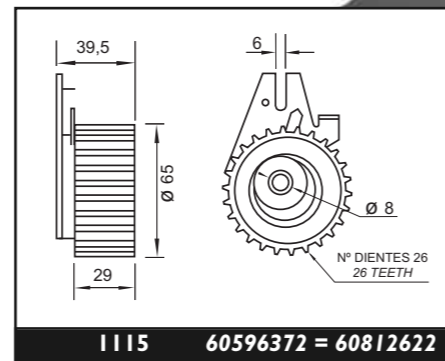
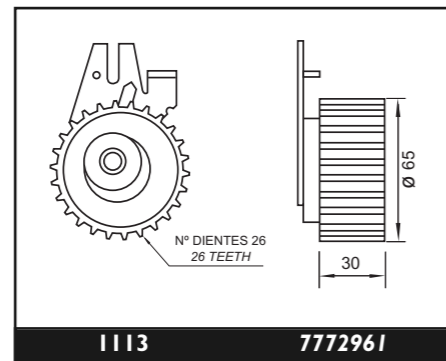
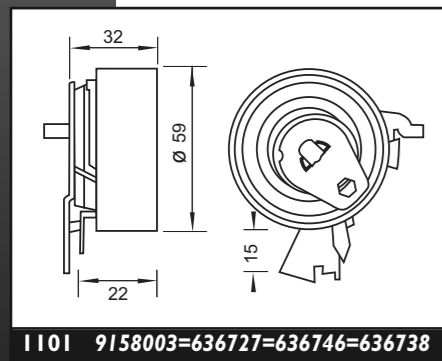

MODELO MODEL	COMB./FUEL	MOTOR ENGINE	AÑO YEAR		CÓDIGO CODE			NOTA NOTE
			DESDE SINCE	HASTA TO	FIJO FIXED	MÓVIL MOBILE	EM euromotor®	

FIAT MAREA

2.4 TD	2387	D	I85A2000	09/96	04/99	1950	1115	(125 cv) 5 Cil.
2.4 JTD	2387	D	I85A6000	05/99		1950	1115	(136 cv) 5 Cil.

FIAT MULTIPLA

1.6 16v	1581	N	I82A4000	10/95		1950	12091	(103 cv)
1.6 bipower	1581	N/M	I82A4000	04/99		1951	12091	(103 cv / 92 cv)
1.6 blupower	1581	M	I86A3000	04/99		1951	12091	(95 cv)
1.9 JTD	1910	D	I82B4000	04/99		1950	1115	(110 cv)

FIAT PALIO - SIENA

1.3 Fire	1242	N	I88A5000	01/01			12155	
1.3 mpi		N	I76B900	06/99			12455 12155	Man.Tens. Aut.Tens.
1.4 Fire	1368	N		04/07			12155	
1.6 8v	1580	N	I78E2000-I78B5000	06/98		1822		
1.6 16v	1581	N	I78B3000	04/96		1951	12091	
1.8 R	1796	N	C18N2	09/06			1101	
1.7 D	1697	D		04/96		1820	1819	
1.7 TD	1697	D	I76A3000	04/96		1820	1819	
1.9 DS	1910	D	I88A3000	01/00		1950	1115	(63 cv)

FIAT PANDA

750	770	N		01/86		1822		Motor FIRE Engine
1.0	999	N		01/86		1822		Motor FIRE Engine
1.1	1108	N	I56C046-I76C2000	10/91		1822		Motor FIRE Engine
D	1302	D	I56A5000	04/96	10/92	1840	1825	

FIAT PUNTO

1.4 Fire	1368	N		09/07			12155	
1.8	1796	N		02/07			12275	

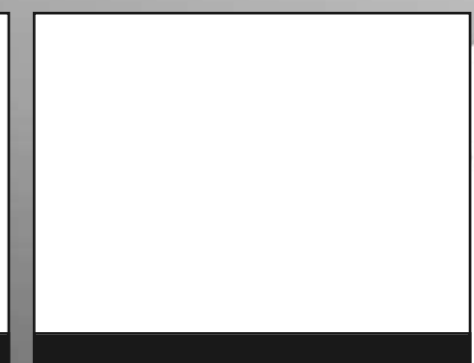
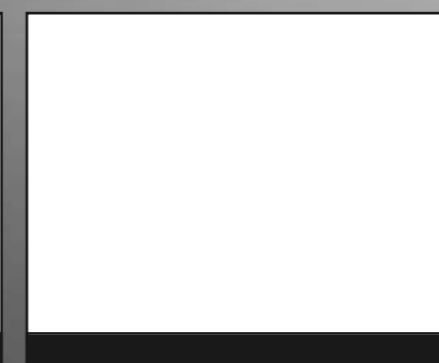
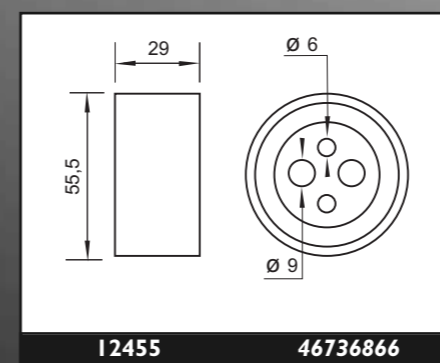
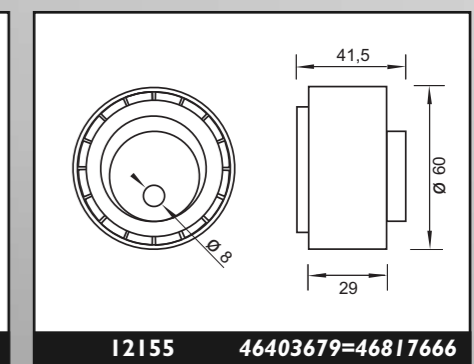
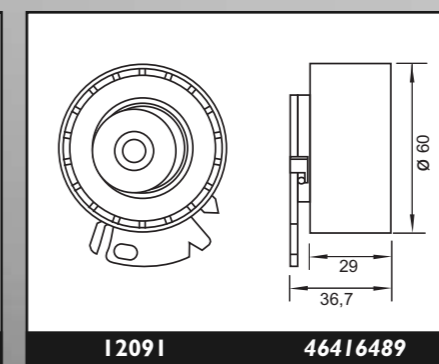
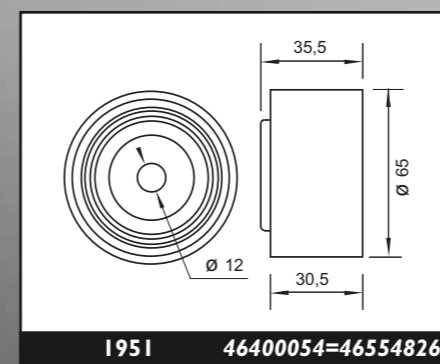
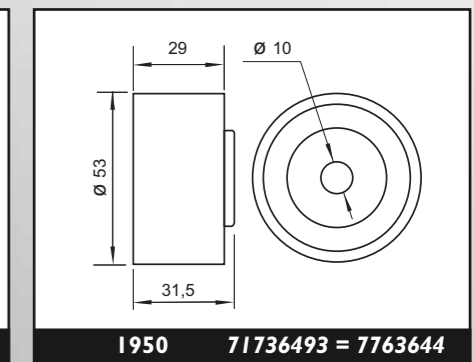
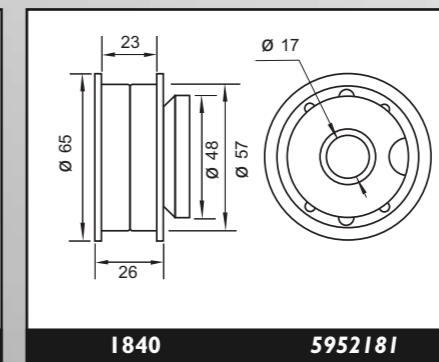
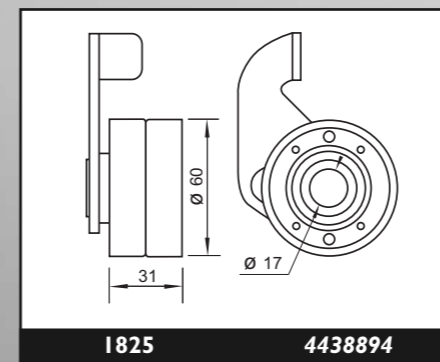
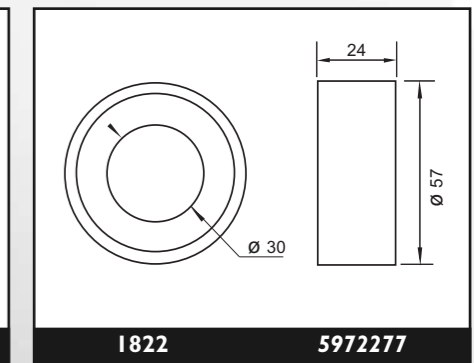
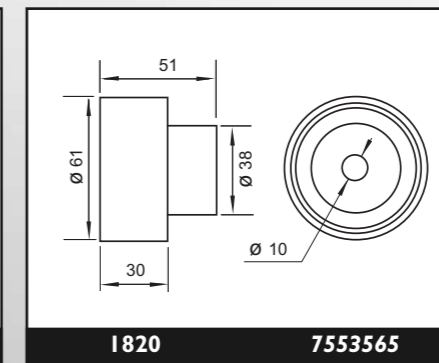
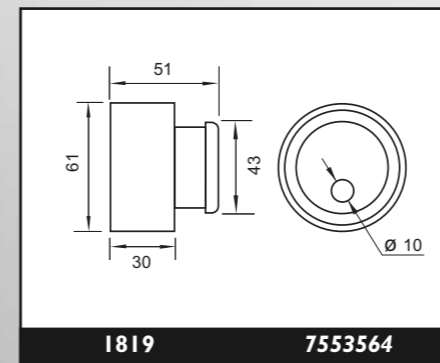
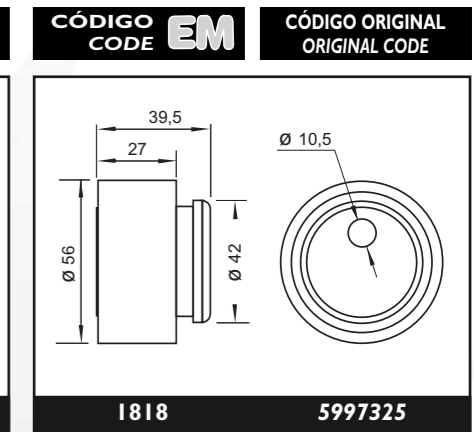
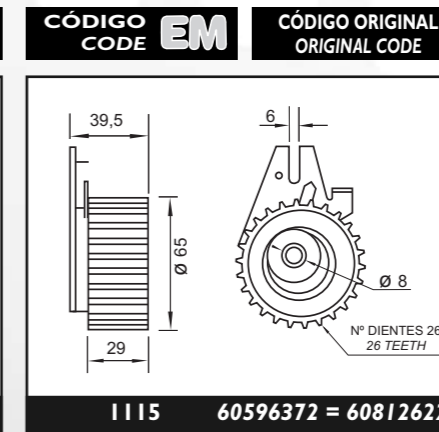
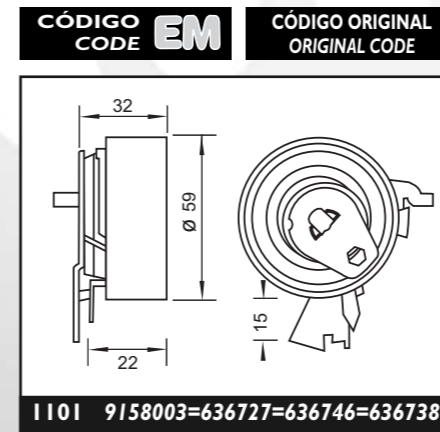

MODELO MODEL	COMB./FUEL	MOTOR ENGINE	AÑO YEAR		CÓDIGO CODE		
			DESDE SINCE	HASTA TO	FIJO FIXED	MÓVIL MOBILE	NOTA NOTE

FIAT REGATA

1.5 - 85	1478	N	138B...-149A...	1983	1985	1872		
1.5 - 85	1478	N	138B...-149A...	1985	1989		1818	
1.6 100S	1585	N	138B...-149A...	1986	1989		1872	
1.6 SCV	1585	N	149A...			1822		
2.0	1988	N		1993/95			1832	
2.0	1988	N		1995			1823	

FIAT SPAZIO

1.0	995	N		1985		12027		
1.3	1290	N		08/85		1855		
1.4	1372	N	160A1000	07/88		1822		
1.3 D	1302	D	146B1000	05/86		1840	1825	

FIAT STILO

1.8 8v		N					1101	
1.8 16v	1747	N	192A4000	10/01		12393	12354	
2.4 20v	2446	N	192A2000	10/01		1950	1113	Abarth
1.9 JTD	1910	D	192A1000-192A3000	10/01		1950	1115	
1.9 MJ 16v	1910	D		01/04		12467	1115	(140 cv)

FIAT TEMPRA

1.4	1372	N	159A2000-160A1046	1990	08/96	1822		
1.6	1580	N	836A4000	1990	08/96	1822		

CÓDIGO CODE	EM	CÓDIGO ORIGINAL ORIGINAL CODE	CÓDIGO CODE	EM	CÓDIGO ORIGINAL ORIGINAL CODE	CÓDIGO CODE	EM	CÓDIGO ORIGINAL ORIGINAL CODE
----------------	----	----------------------------------	----------------	----	----------------------------------	----------------	----	----------------------------------

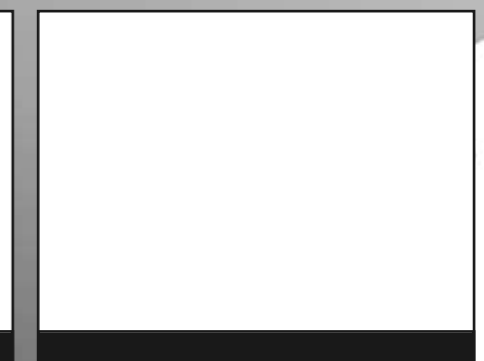
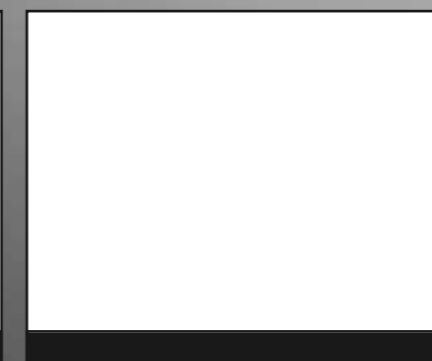
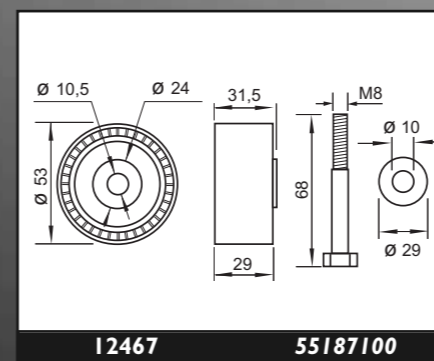
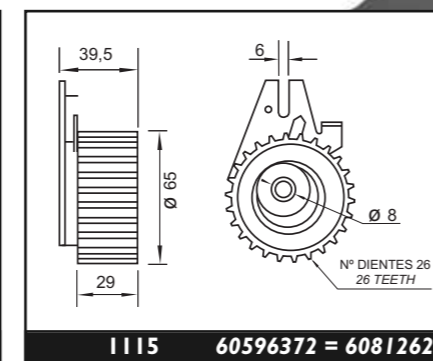
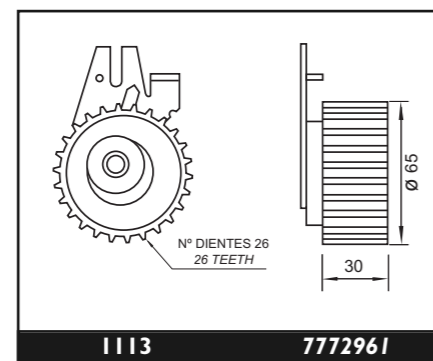
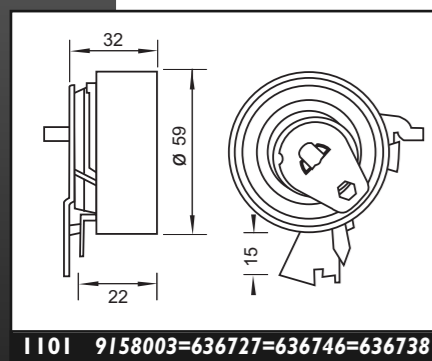
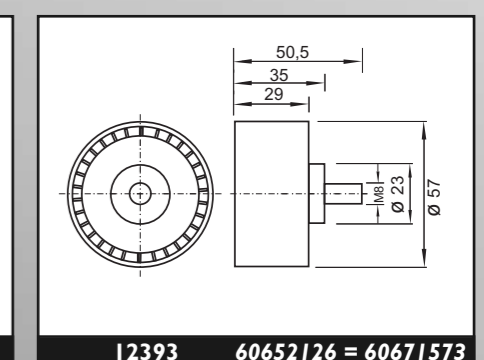
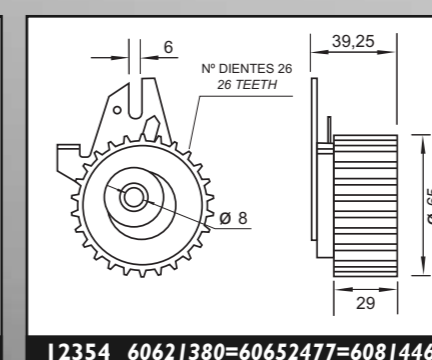
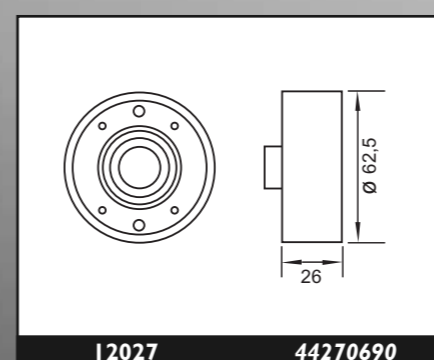
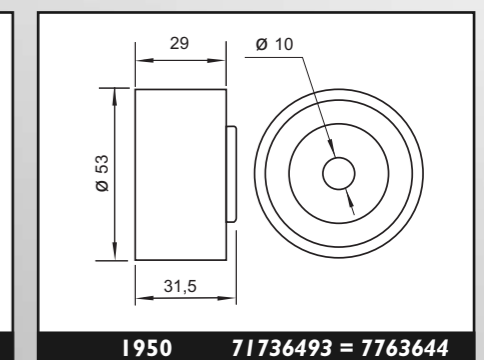
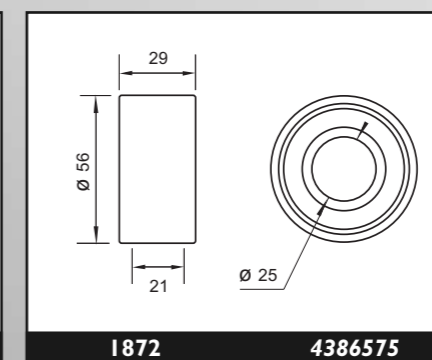
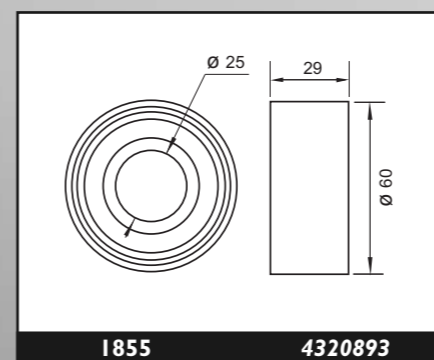
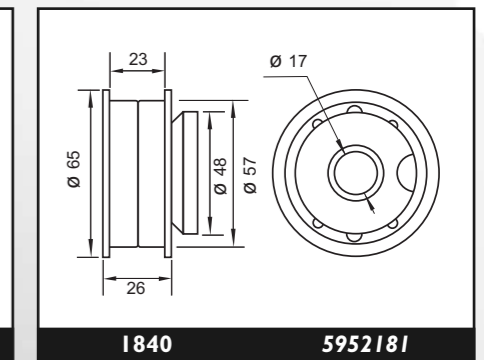
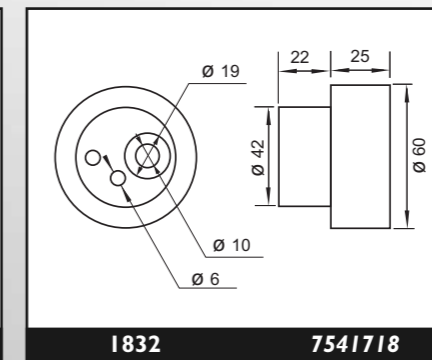
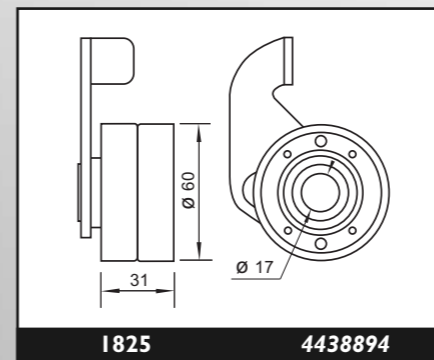
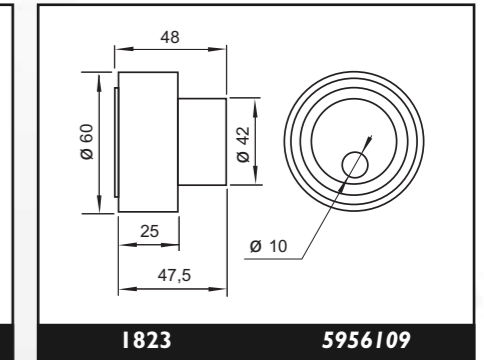
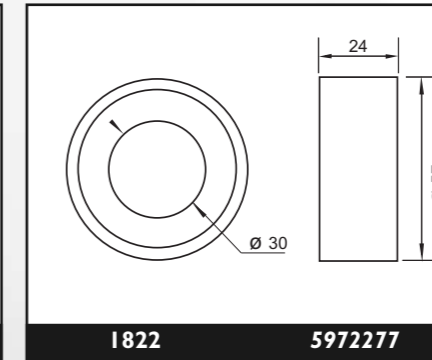
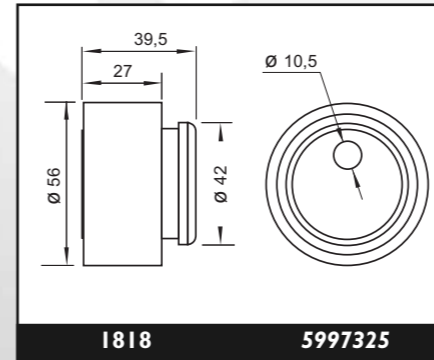

MODELO MODEL	COMB./ FUEL	MOTOR ENGINE	AÑO YEAR		CÓDIGO CODE EM euromotor®		
			DESDE SINCE	HASTA TO	FIJO FIXED	MÓVIL MOBILE	NOTA NOTE

FIAT TEMPRA

1.8	1750	N	I59A4000	1990	08/93		1823	
1.8	1750	N	I59A4046-835C2000 835C4000-836A5000	1992	08/96		1832	
2.0	1995	N	I59A6046 / A6011	1990	08/96		1832	
1.9 D	1930	D	I60A7000-I60A6000- I60A6046-I60B6046- I60D1000	1990	08/96	1889	1835	
1.9 TD	1930	D	I60A7000-I60A6000- I60A6046-I60B6046- I60D1000	1990	08/96	1889	1835	

FIAT TIPO

1.1	1108	N	I60A3.000	01/88	04/95	1822		Motor FIRE Engine
1.4	1372	N	I60A1.000	01/88	04/95	1822		Motor FIRE Engine
1.6	1595	N	I60A2.000	01/88	04/95	1822		Motor FIRE Engine
1.8	1756	N	I59A4000	1994	1995		1823	
1.8	1756	N	I59A4046-835C2000 835C4000-836A5000	1990	1995		1832	
1.8 16v	1756	N	I60A5000	11/89	06/92		1818	
2.0 8v	1995	N	I59A6046-I59A6011	06/90	04/95		1832	
2.0 16v	1995	N	I60A8046	07/91	04/95		1818	
1.7 D	1697	D	I49B4000	01/88	10/94	1889	1835	
1.9 D	1930	D	I60A7000	07/91	08/96	1889	1835	
1.9 TD	1930	D	I60A6000-I60A6046 I60B6046-I60D1000	1990	04/95	1889	1835	

FIAT ULYSSE

1.8	1750	N	LFW	05/97			1811	
2.0	1997	N	RFU - XU10J2C	06/94	07/98		1811	
2.0 16v	1997	N	RFV	05/98		1862	1943	
2.0 16v	1997	N	RFN	09/00		92102	12334	
1.9 TD	1905	D	D8B-DHX-XUD9TF	02/95		1900	1901	

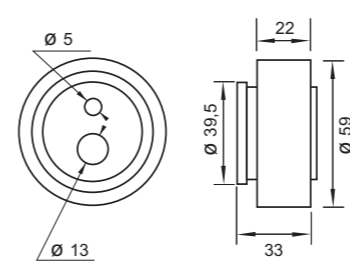
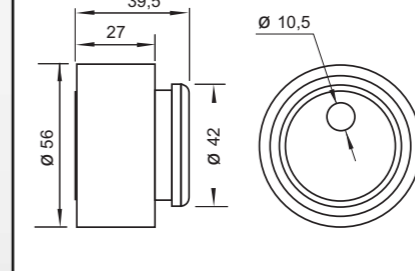
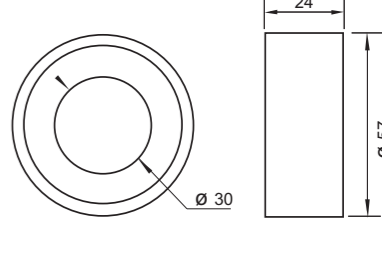
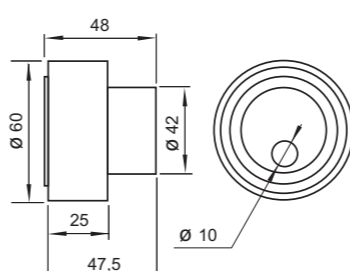
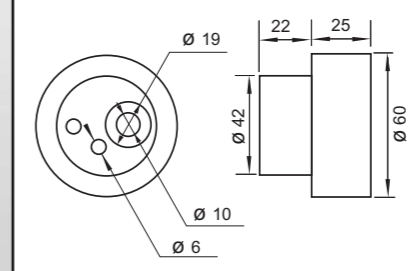
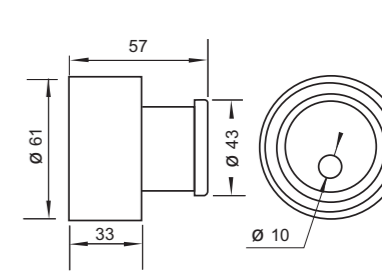
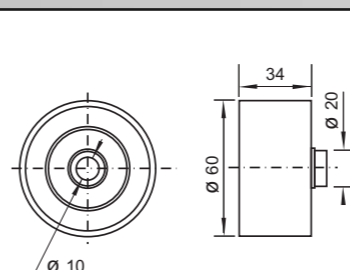
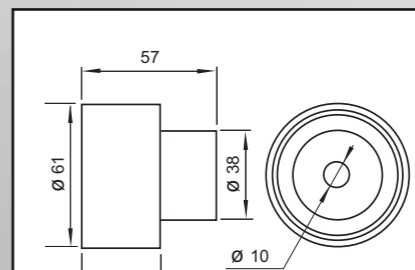
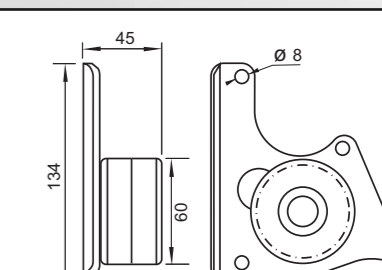
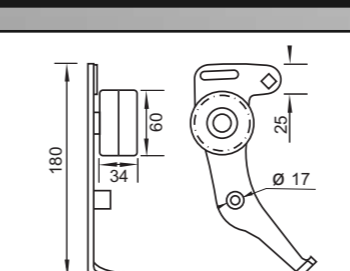
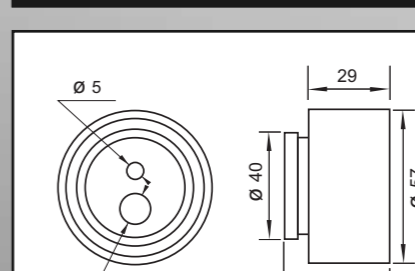
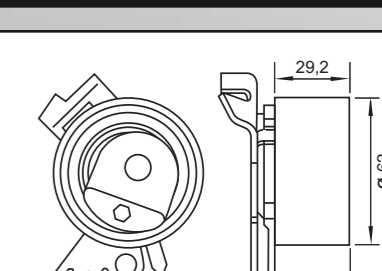
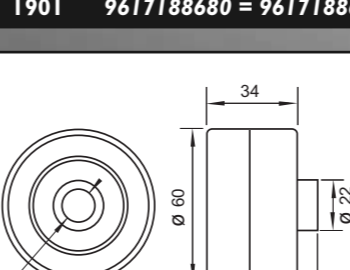
CÓDIGO CODE EM	CÓDIGO ORIGINAL ORIGINAL CODE	CÓDIGO CODE EM	CÓDIGO ORIGINAL ORIGINAL CODE	CÓDIGO CODE EM	CÓDIGO ORIGINAL ORIGINAL CODE
	9605266280		5997325		5972277
	5956109		5972277		7596728=7596877
	9400830149= 9400830379		5970621=7596727=7596876=60808692		9615923380=9615923380
	9617188680 = 9617188680		1473010080 = 9622574480		9643329681
	9632722180				

MODELO MODEL	COMB./ FUEL	MOTOR ENGINE	AÑO YEAR		CÓDIGO CODE EM euromotor®		
			DESDE SINCE	HASTA TO	FIJO FIXED	MÓVIL MOBILE	NOTA NOTE

FIAT ULYSSE

2.0 JTD 8v	1997	D	RHZ	01/99		12094 1119	12093 1118	
2.0 JTD 16v	1997	D	RHW	09/99		12094	12093	
2.1 TD	2088	D	P8C	03/96	10/99	1862	1871	
2.2 JTD	2179	D	DW	02/02		12094	12093	

FIAT UNO

1.0	994	N	146A.000-156A2.100	1983	12/93	1822		
1.1	1116	N	146...-156...-160...	1983	12/93	1822		
1.1	1116	N	138.000	1983	12/88	1872		
1.1	1116	N	138.000-149C...	1983			1818	Desde From chassis 967609, 1821990
1.3	1302	N	138B2.000	1983	12/88	1872		
1.3		N	138B...-149C...	1983			1818	
1.3 MPI	1242	N	176B900	07/00			12155	
1.3 Fire	1242	N	188A5000	04/02			12455 14012	Man. Tens. Aut. Tens.
1.4 Fire	1368	N		09/07			14012	
1.4 Turbo	1372	N	146...-156...-160...	09/89	12/96	1822		
1.5		N	138B...-149C...	1983			1818	
1.3 D	1302	D	146B1000	06/83	06/92	1840	1825	
1.4 TD	1367	D	146B3000	10/86	10/90	1820	1819	
1.7 D	1697	D	146B2000	07/86	12/93	1820	1819	
1.9 D	1930	D	149B5046	09/89	03/94	1820	1819	

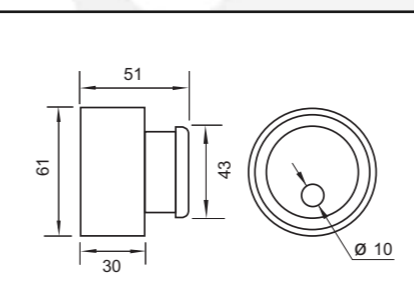
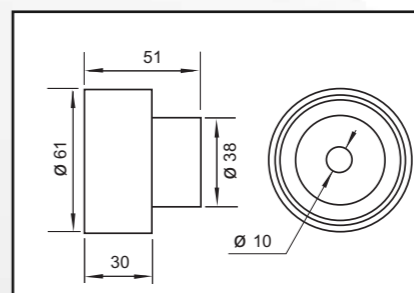
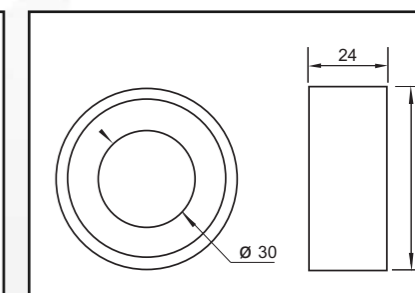
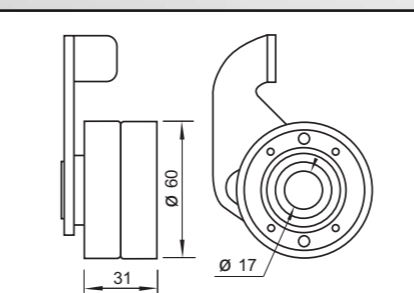
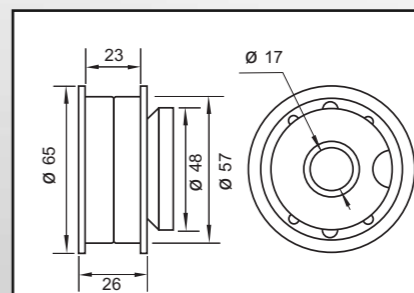
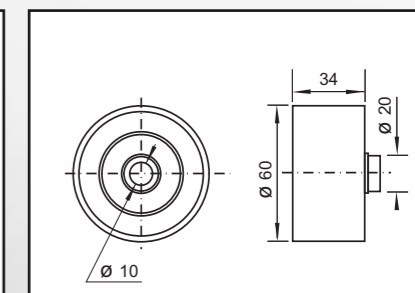
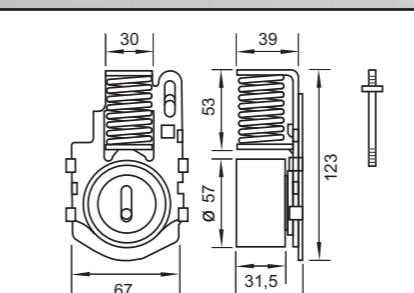
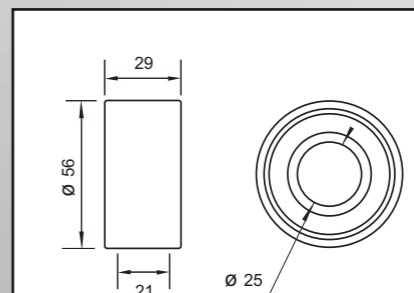
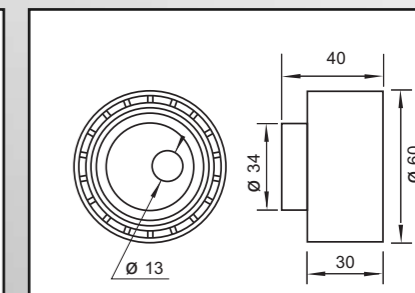
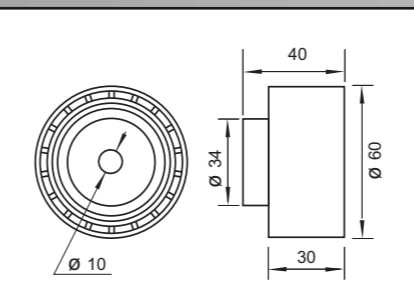
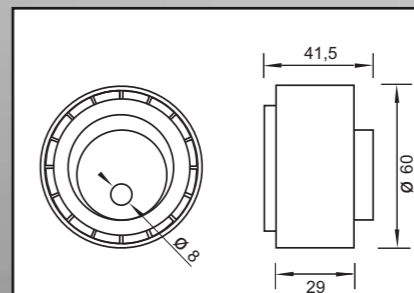
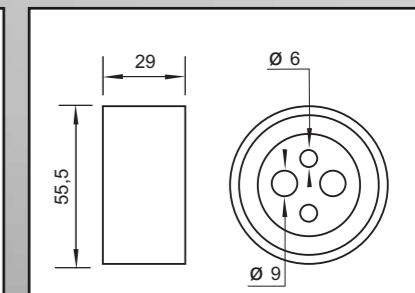
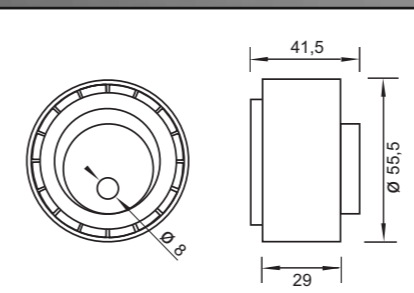
CÓDIGO CODE EM	CÓDIGO ORIGINAL ORIGINAL CODE	CÓDIGO CODE EM	CÓDIGO ORIGINAL ORIGINAL CODE	CÓDIGO CODE EM	CÓDIGO ORIGINAL ORIGINAL CODE
	7553564		7553565		5972277
	4438894		5952181		9400830149= 9400830379
	9400818199		4386575		9400829629
	9400830319		46403679=46817666		46736866
	55183497				

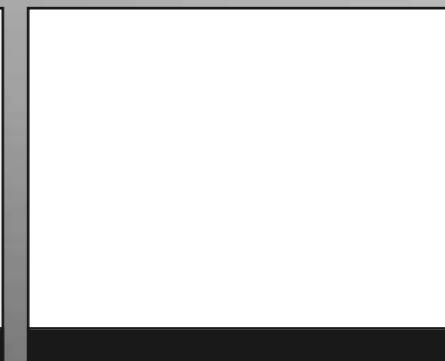
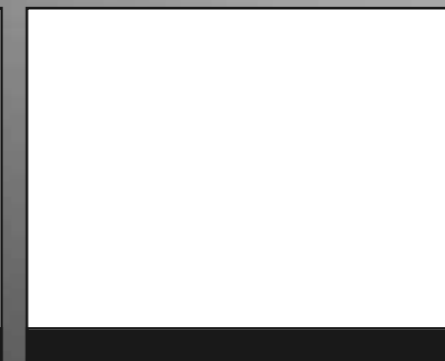
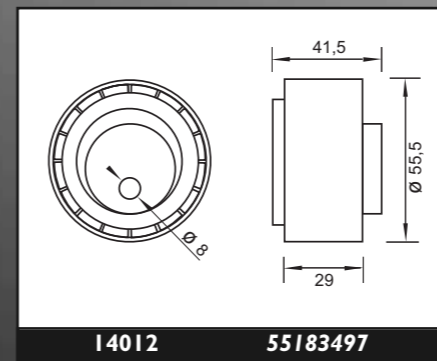
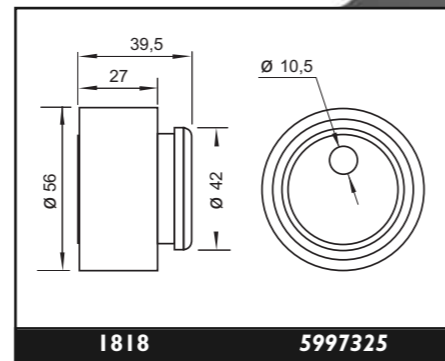
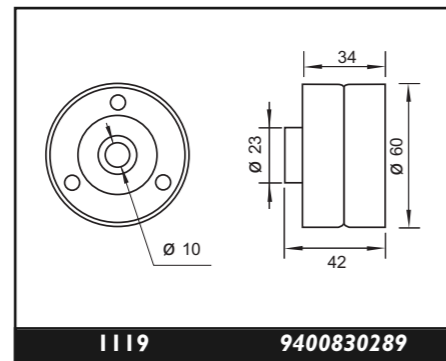
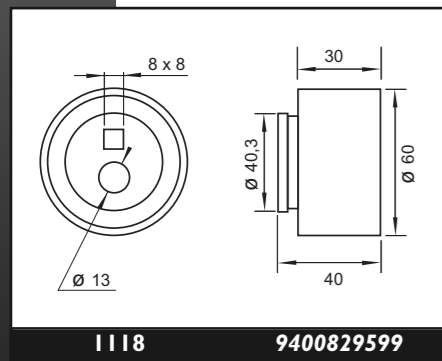

MODELO MODEL	COMB. / FUEL	MOTOR ENGINE	AÑO YEAR		CÓDIGO CODE EM euromotor®		
			DESDE SINCE	HASTA TO	FIJO FIXED	MÓVIL MOBILE	NOTA NOTE

FIAT X 1/9

1.3	1281	N	128AS000			1851		
1.5	1499	N	138AS000			1872		

Utilitarios

FIAT DAILY

2.5 D	2500	D	Sofim			1816	1821	Sólo rodam. Bearing only
2.5 D	2500	D	8144.65 Sofim	1981		12389	12503	Con base With plate
2.5 TD	2500	D	Sofim			1816	1821	Sólo rodam. Bearing only
2.5 TD	2500	D	8144.65 Sofim	1981		1816	12503	Con base With plate
2.8	2798	D		04/99		1816	1821	Correa/ Belt 153 dientes/ teeth

FIAT DOBLO

1.2	1242	N	223A5000	03/01		1822		
1.2 16v	1242	N		11/01			12155	
1.6 16v	1581	N		2001		1951	12091	
1.9 D	1910	D		11/00		1950	1115	
1.9 JTD	1910	D		2001		1950	1115	

FIAT DUCATO

2.0	1970	N	170B	01/86	03/88		1835	
2.0	1970	N	170D	04/88	03/94	1889	1835	
2.0	1998	N	RFW - R5B	04/94	03/03		1943	
1.9 D	1930	D	149A1000-280A1000	02/87	03/94	1889	1835	
1.9 D	1930	D	230A2000/3000/4000	04/94	04/02	1889	1835	

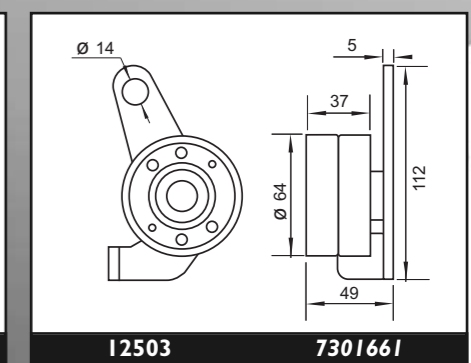
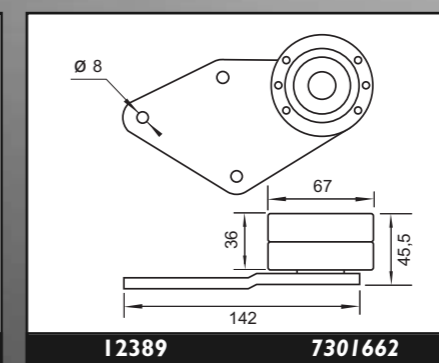
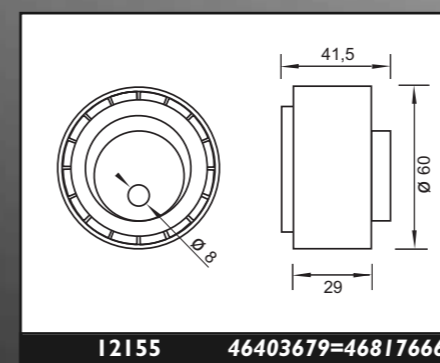
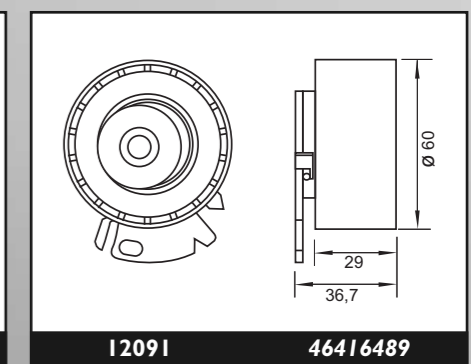
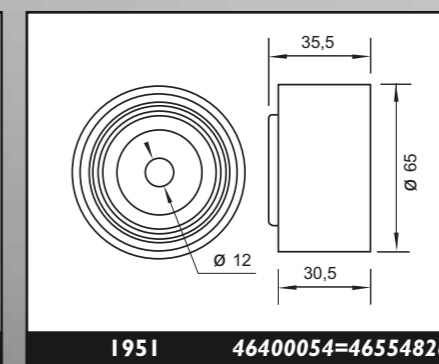
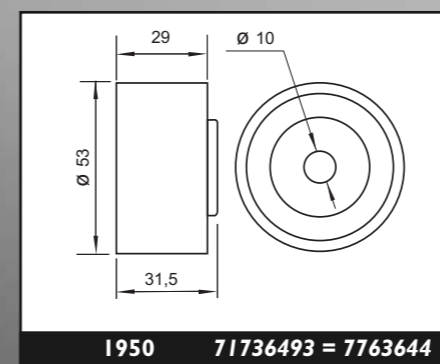
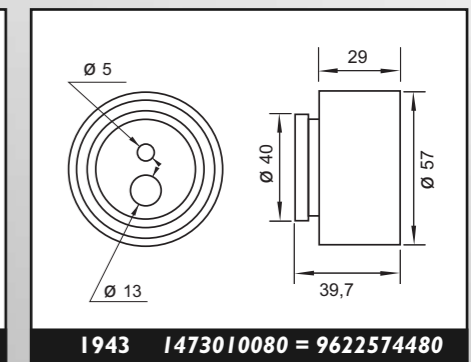
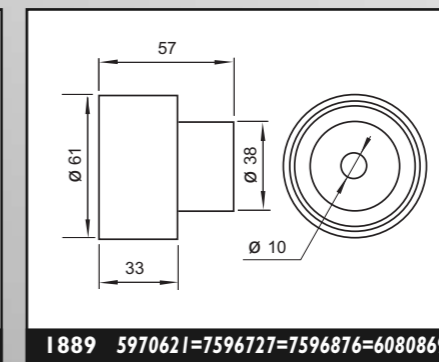
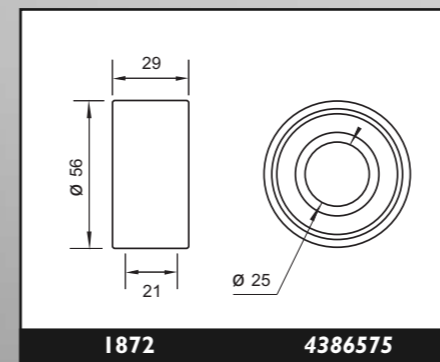
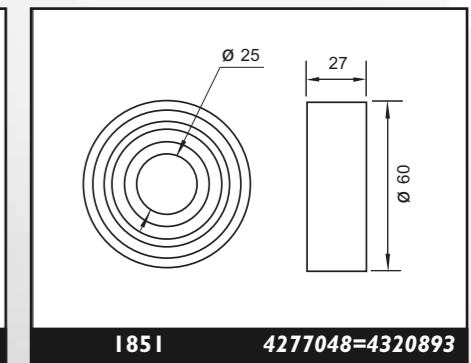
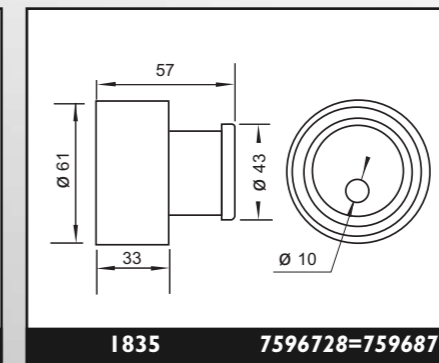
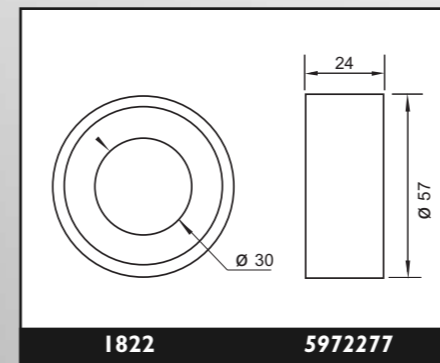
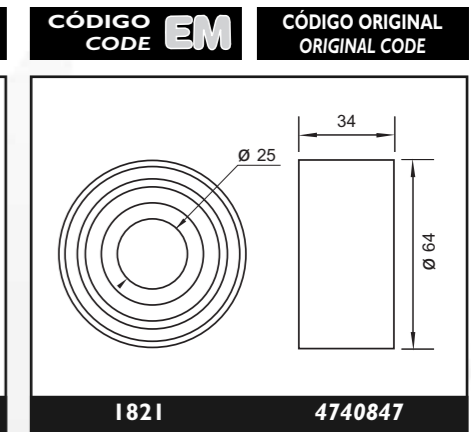
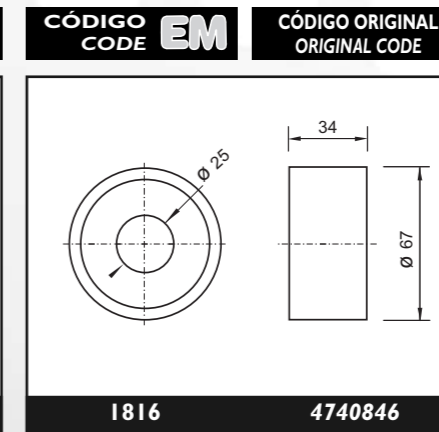
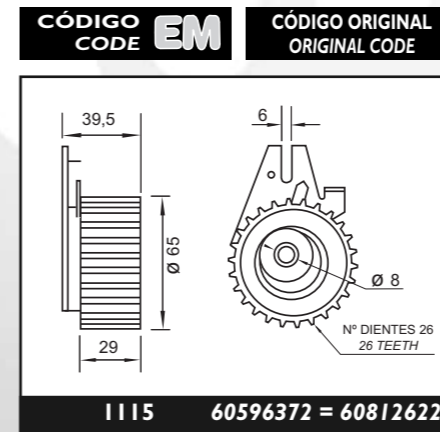

MODELO MODEL	MOTOR ENGINE	AÑO YEAR		CÓDIGO CODE		
		DESDE SINCE	HASTA TO	FIJO FIXED	MÓVIL MOBILE	NOTA NOTE

FIAT DUCATO

1.9 D	1905	D	D9B - DHX	04/94	04/02	1900	1901	
1.9 TD	1930	D	149A1000-280A1000	02/87	03/94	1889	1835	
1.9 TD	1930	D	230A2000/3000/4000	04/94	04/02	1889	1835	
1.9 TD	1905	D	D9B - DHX XUD9TF	04/94	04/02	1900	1901	
2.0 JTD	1997	D	RHU - DW10	10/01		12094	12093	
2.5 D	2500	D	8140.67-8140.47	04/94		1816	1821	Sólo rodam. Bearing only
2.5 D	2500	D	8140.67-8140.47	04/94		12389	12503	Con base With plate
2.5 D	2500	D	8140.67-8140.47	02/96		1816	1816	Correa/ Belt 153 dientes/ teeth
2.5 TDI	2500	D	8140.47	02/96		1816	1816	Correa/ Belt 153 dientes/ teeth
2.8 TD	2800	D	8140.43-8140.63	05/98		1816	1816	Sólo rodam. Bearing only
2.8 TD	2800	D	8140.43-8140.63	05/98		12389	12503	Con base With plate

FIAT FIORINO

1.3 D	1288	N	146B1000	02/83	12/93	1825	1840	
1.3	1301	N	146C6000	01/88	12/94	1822		
1.3 mpi	1242	N	176.B900	06/99			12455 12155	Man.Tens. Aut.Tens.
1.3 Fire	1242	N	188A5000	01/01			12155	
1.4 Fire	1368	N					12155	
1.5	1499	N	149C1000	01/88	09/93		1818	

CÓDIGO CODE	EM	CÓDIGO ORIGINAL ORIGINAL CODE	CÓDIGO CODE	EM	CÓDIGO ORIGINAL ORIGINAL CODE	CÓDIGO CODE	EM	CÓDIGO ORIGINAL ORIGINAL CODE
1822		5972277	1825		4438894	1835		7596728=7596877
1840		5952181	1889		5970621=7596727=7596876=60808692	1900		9615923380=9615923380
1901		9617188680 = 9617188680	12093		9400829629	12094		9400830319
12155		46403679=46817666	12389		7301662	12455		46736866
12503		7301661						

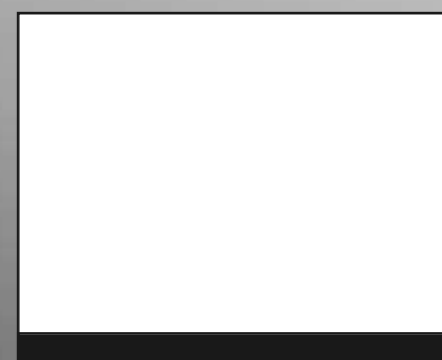
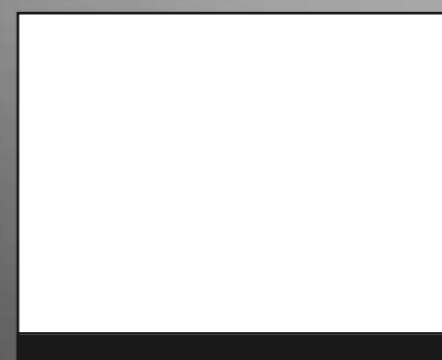
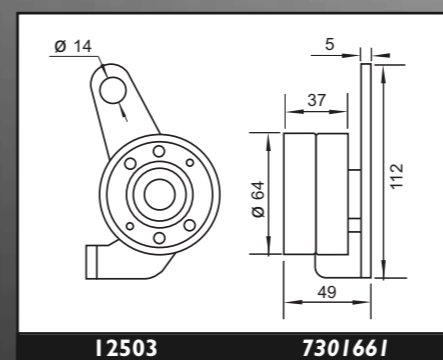
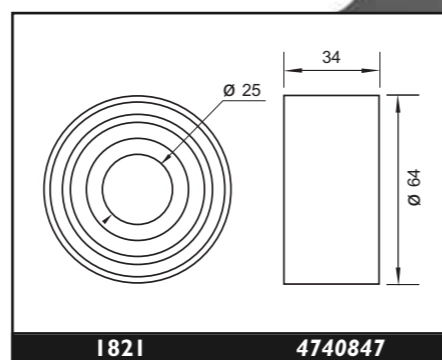
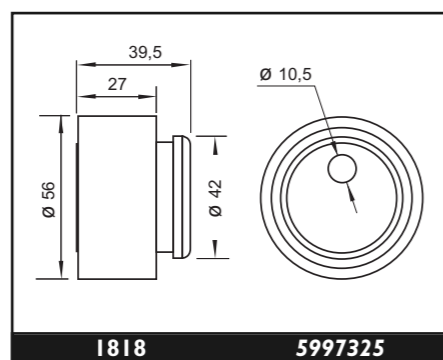
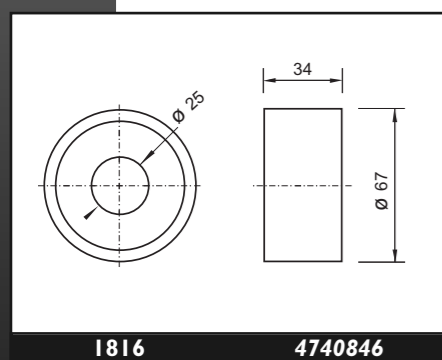

MODELO MODEL	MOTOR ENGINE	AÑO YEAR		CÓDIGO CODE		
		DESDE SINCE	HASTA TO	FIJO FIXED	MÓVIL MOBILE	NOTA NOTE

FIAT FIORINO

1.6	1581	N	146C6000	01/88	12/93	1822	
D	1288	D	127A5000	03/82	1993	1840	1825
1.4	1372	D	160A1.000	01/88	04/95	1822	
1.7 D	1697	D	146B2.000	05/88	07/01	1820	1819
1.7 TD	1697	D	146D7.000	05/88	07/01	1820	1819

FIAT MARENGO

1.9 D	1930	D	160A7000-160A6000	1990	08/96	1889	1835
1.9 TD	1930	D	160A7000-160A6000	1990	08/96	1889	1835
1.9 TD	1910	D	182A8000-182A7000	09/96		1950	1115 (75 cv-100 cv)
1.9 JTD	1910	D	182B4000	04/99		1950	1115 (105 cv-110 cv)

FIAT PENNY

1.7 D	1698	D	149B3000	01/87	12/91	1889	1835
-------	------	---	----------	-------	-------	------	------

FIAT SCUDO

1.6	1581	N	220A2000	02/96	03/03	1822	
1.9 D	1905	D	D9B - D8B - DHX	02/96	03/03	1900	1901
1.9 D	1867	D	DW8 - WJZ	12/99		1119	1118
1.9 TD	1905	D	D9B - D8B - DHX	02/96		1900	1901
2.0 JTD 8v	1997	D	RHX - RHZ - RHW	12/99		12093	12094 (95cv - 110cv)
2.0 JTD 16v	1997	D	RHX - RHZ - RHW	12/99		12093	12094 (95cv - 110cv)

CÓDIGO CODE	EM	CÓDIGO ORIGINAL ORIGINAL CODE	CÓDIGO CODE	EM	CÓDIGO ORIGINAL ORIGINAL CODE	CÓDIGO CODE	EM	CÓDIGO ORIGINAL ORIGINAL CODE
1115	60596372 = 60812622		1118	9400829599		1119	9400830289	
1819	7553564		1820	7553565		1822	5972277	
1825	4438894		1835	7596728=7596877		1840	5952181	
1889	5970621=7596727=7596876=60808692		1900	9615923380=9615923380		1901	9617188680 = 9617188680	
1950	71736493 = 7763644		12093	9400829629		12094	9400830319	

MODELO MODEL	COMB. / FUEL	MOTOR ENGINE	AÑO YEAR		CÓDIGO CODE EM euromotor®		
			DESDE SINCE	HASTA TO	FIJO FIXED	MÓVIL MOBILE	NOTA NOTE

FIAT STRADA

1.3 mpi	1242	N	I78E2000/B5000	06/98			12455 14012	Man.Tens. Aut.Tens.
1.4	1368	N		04/07			12155	
1.7 TD	1697	D	I76A3000	04/96		1820	1819	
1.9 DS	1910	D	I88A3000	01/00		1950	1115	(63 cv)

FIAT TALENTO

2.0	1970	N	I70B	01/86	03/88	1889	1835	
1.9 D	1930	D	I49A1000-280A1000	02/87	03/94	1889	1835	
1.9 TD	1930	D	I49A1000-280A1000	02/87	03/94	1889	1835	

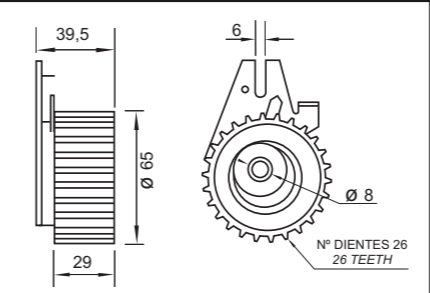
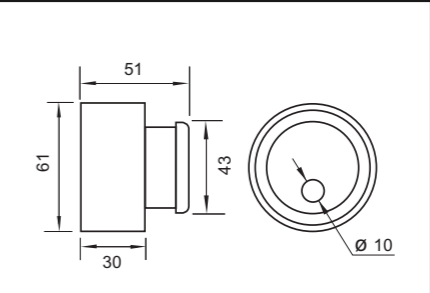
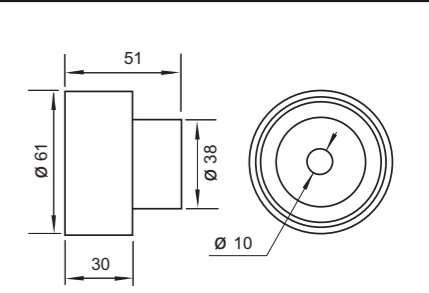
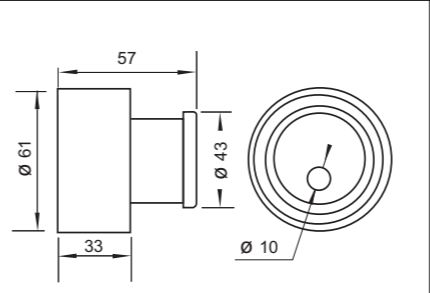
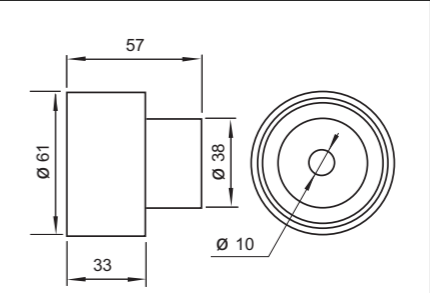
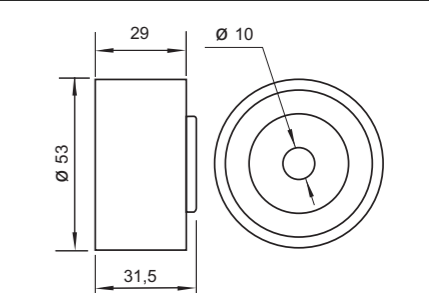
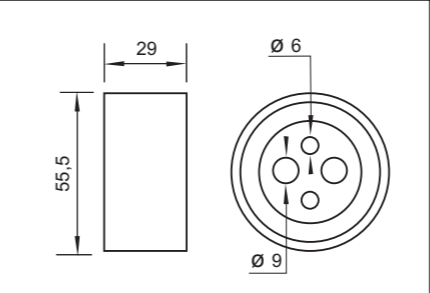
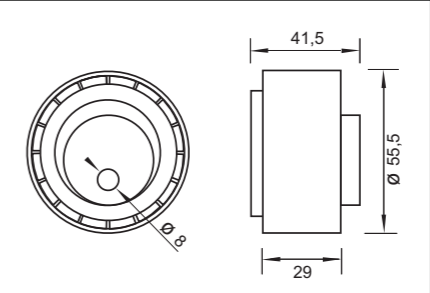
CÓDIGO CODE EM	CÓDIGO ORIGINAL ORIGINAL CODE	CÓDIGO CODE EM	CÓDIGO ORIGINAL ORIGINAL CODE	CÓDIGO CODE EM	CÓDIGO ORIGINAL ORIGINAL CODE
					
1115	60596372 = 60812622	1819	7553564	1820	7553565
					
1835	7596728=7596877	1889	5970621=7596727=7596876=60808692	1950	71736493 = 7763644
					
12455	46736866	14012	55183497		

EM euromotor®

VERSION PDF 2010



$\varnothing 18$

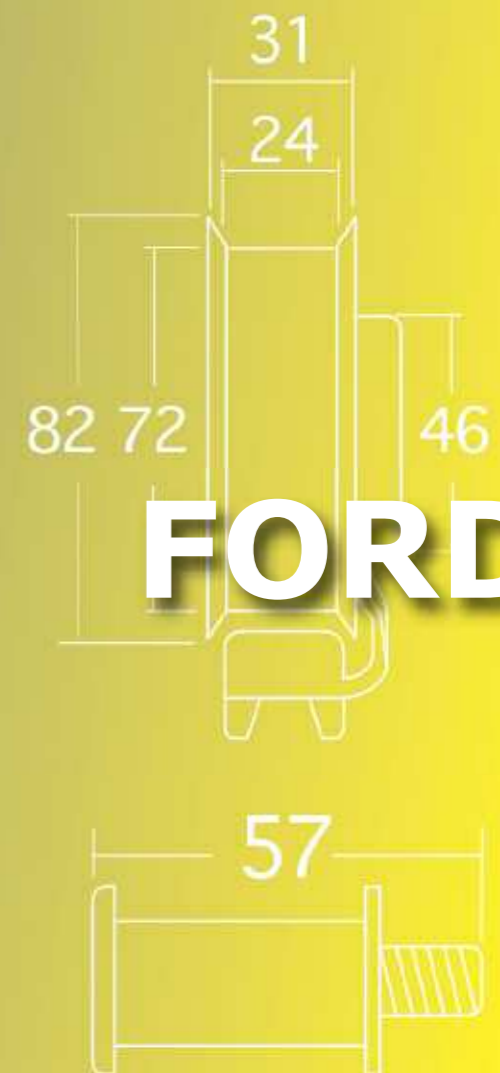

FORD



MODELO MODEL	COMB./FUEL	MOTOR ENGINE	AÑO YEAR		CÓDIGO CODE		
			DESDE SINCE	HASTA TO	FIJO FIXED	MÓVIL MOBILE	NOTA NOTE

FORD CAPRI

2.0	1993	N	TL20 (OHC)	01/78	12/85		1839	
-----	------	---	------------	-------	-------	--	------	--

FORD CONSUL

2.0	1993	N	TL20 (OHC)	01/72	12/82		1839	
-----	------	---	------------	-------	-------	--	------	--

FORD CORTINA

		N	TL (OHC)				1839	
--	--	---	----------	--	--	--	------	--

FORD COUGAR

2.0 16v	1988	N	EDBA ZH20EFI	01/99	09/02	12166 12157 12167	12169	
---------	------	---	-----------------	-------	-------	-------------------------	-------	--

FORD ECOSPORT

1.4 TDCI	1399	D	DV4TD	03/03		12377	12498	
2.0 16v	1988	N	EDDB - EDDC EDDD - EDDF	02/04		12157 12167	12169	

FORD ESCAPE

2.0 16v	1988	N	EDDB - EDDC EDDD - EDDF	02/01		12157 12167	12169	
---------	------	---	----------------------------	-------	--	----------------	-------	--

FORD ESCORT

1.4	1392	N	HLI4	07/83			1837	
1.6	1597	N	HLI6	01/80			1837	
1.6	1597	N	TLI6 (OHC)	1975			1839	
1.6	1598	N	AB9 (Audi)	02/90			1805	
1.6 16v	1597	N	LIH-LIE-ZH ZETEC	09/92		1904 1096	1903	
1.8	1781	N	AB9 (Audi)	09/90			1805	
1.8 16v	1796	N	RDA-RQB-RKC ZH ZETEC	09/92		1904 1096	1903	
1.8 16v	1796	N	RDA-RQB-RKC ZH ZETEC	09/92		1904 1096	1903	
2.0	1993	N	TL20 (OHC)	1975			1839	

CÓDIGO CODE	EM	CÓDIGO ORIGINAL ORIGINAL CODE	CÓDIGO CODE	EM	CÓDIGO ORIGINAL ORIGINAL CODE	CÓDIGO CODE	EM	CÓDIGO ORIGINAL ORIGINAL CODE
1096		6744307	1805		026109243E	1837		6131141=6182891
1839		75HM-6K254AA=1496915	1903		6635941-6635942=928M6K254AC	1904		6635942
12157		1038384	12166		1053942	12167		1095025=1213852
12169		1000159=1072031=1107573	12377		1145955	12498		1145947

MODELO MODEL	COMB./FUEL	MOTOR ENGINE	AÑO YEAR		CÓDIGO CODE			NOTA NOTE
			DESDE SINCE	HASTA TO	FIJO FIXED	MÓVIL MOBILE	EM euromotor®	

FORD ESCORT

1.8 D	1753	D	RT - RF	01/89	11/95	1902	12162 1915	
1.8 D	1753	D	RT - RF - RVA	12/95	01/97	1902	1985 1915	
1.8 D	1753	D	RT - RF - RVA	02/97		1123	1915 1099	
1.8TD	1753	D	RT - RF	01/89	11/95	1902	12162 1915	
1.8TD	1753	D	RT - RF - RVA	12/95	01/97	1902	1985 1915	
1.8TD	1753	D	RT - RF - RVA	02/97		1123	1915 1099	

FORD FIESTA

1.2 16v	1242	N	DHA-DHC-DHD-DHB	08/95	08/99		12297	
1.2 16v	1242	N	ZETEC	01/00			12505	
1.3	1297	N	HLI3CVH -	05/76	12/89		12504	
1.4	1392	N	HLI4 CVH -	01/86	11/95		1837	
1.4	1398	N	ZHI4FHE	03/97	12/98		12297	
1.4	1398	N	ZHI4FHE	01/99			12505	
1.6	1591	N	HLI6 -	01/81	12/95		1837	
1.6	1597	N	LUH - ZHI6	01/89		1904 1096	1903	
1.6 16v	1596	N	LIT - LIV	02/00	11/01		12297	
1.6 16v	1596	N	ZETEC	01/00			12505	
1.6 16v	1596	N	ZHI6SEFI	12/01			12505	
1.8 16v	1796	N	RDB-ZETEC-RQC ZHI8	02/92		1904 1096	1903	
1.4TDCi	1399	D	DV4TD-CBK-F6JA DV4TED4	09/02		12377	12498	
1.8 D	1753	D	RTD-RTG-RTC	01/89	11/95	1902	12162	Bomba inyectora Injection pump
1.8 D	1753	D	RTG-RTC	12/95	08/96	1902	12162 1915	Con guía correa With belt guide Bomba inyectora Injection pump

CÓDIGO CODE	EM	CÓDIGO ORIGINAL ORIGINAL CODE	CÓDIGO CODE	EM	CÓDIGO ORIGINAL ORIGINAL CODE	CÓDIGO CODE	EM	CÓDIGO ORIGINAL ORIGINAL CODE
1096		6744307	1099		1099553	1123		1099552
1837		6131141=6182891	1902		6177884=6492482=7053802=1005823	1903		6635941-6635942=928M6K254AC
1904		6635942	1915		6177882=6988203	1985		1005516 = 96FF6K254AA
12162		6178656=6497120	12297		1104087=1111911	12377		1145955
12498		1145947	12504		6145027	12505		1301972=1301973=1361840

MODELO MODEL	COMB./FUEL	MOTOR ENGINE	AÑO YEAR		CÓDIGO CODE EM euromotor®		
			DESDE SINCE	HASTA TO	FIJO FIXED	MÓVIL MOBILE	NOTA NOTE

FORD FIESTA

1.8 D	1753	D	RTD-RTK-RTJ	09/96		1123	1099 1915	Bomba inyectora Injection pump
1.8 D		D	RTG-RTC	09/96		1123	1985 1915	Sin guía correa Without belt guide
1.8TDI	1753	D	RTN-RTP-RTQ	03/00			12333 ó 12454	Bomba inyectora Injection pump

FORD FOCUS

14 16v	1388	N	FXDA - FXDB - FXDC - FXDD	08/98			12297	
16 16v	1596	N	FYDA - FYDB - FYDC - FYDD	08/98			12297	
1.8 16v	1796	N	EYDC-EYDB- EYDD-EYDE-EYDF	05/98	01/99	12157 12166	12169	
1.8 16v	1796	N	EYDC-EYDB-EYDD- EYDE-EYDF	02/99		12157 12167	12169	
2.0 16v	1988	N	EDDC - Eddb - EDDD - EDDF	05/98	01/99	12157 12166	12169	
2.0 16v	1988	N	EDDC - Eddb - EDDD - EDDF	02/99		12157 12167	12169	
1.8 Di	1798	D	BHDA-BHDB-C9DA C9DB-C9DC	10/98			12333 ó 12454	Man.Tens. Aut. Tens.
1.8TDi	1798	D	BHDA-BHDB-C9DA C9DB-C9DC	10/98			12333 ó 12454	Man.Tens. Aut. Tens.
1.8TDDi	1798	D	BHDA-BHDB-C9DA C9DB-C9DC	10/98			12333 ó 12454	Man.Tens. Aut. Tens.
1.8TDCi	1798	D	BHDA-BHDB-C9DA C9DB-C9DC	10/98			12333 ó 12454	Man.Tens. Aut. Tens.

FORD FOCUS C-MAX

1.6 16v	1586	N		07/03			12297	
1.8 16v	1798	N		07/03		12157 12167	12169	
2.0 16v	1999	N		07/03		12157 12167	12169	
1.6TDCi	1560	D		07/03		12377	12498	
2.0TDCi	1997	D	G CAT	07/03		12507	12522	

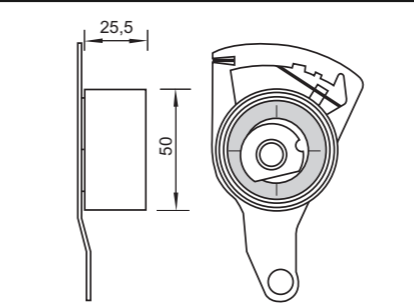
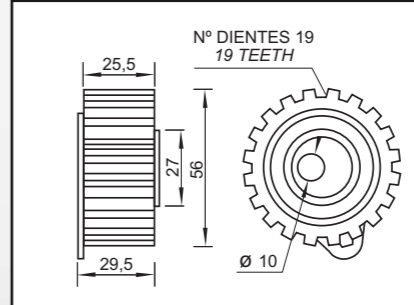
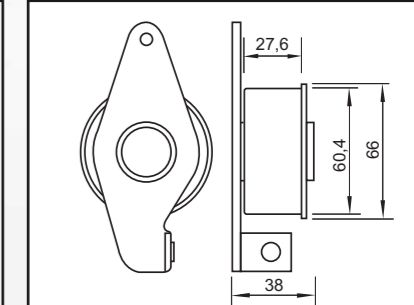
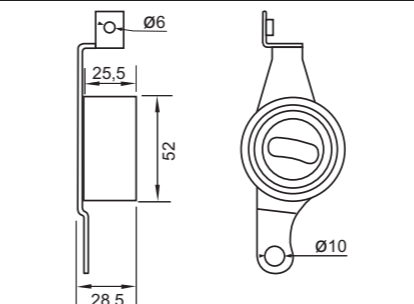
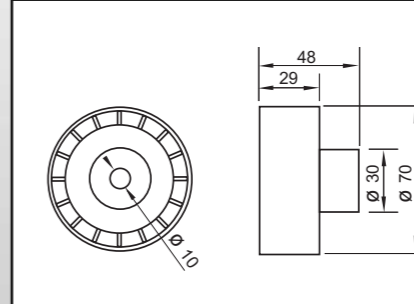
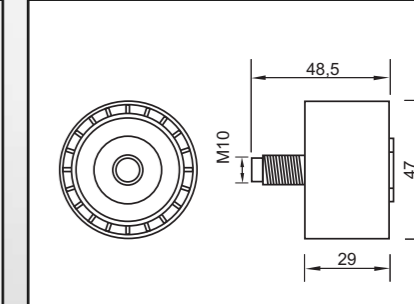
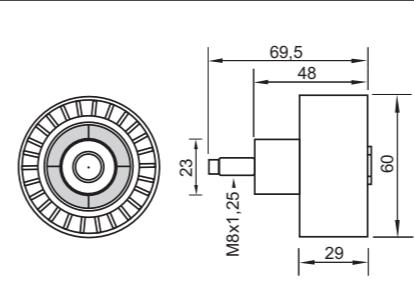
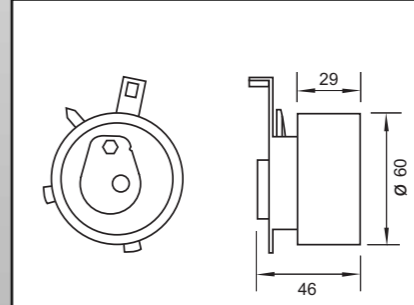
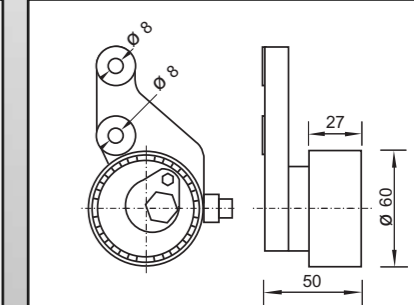
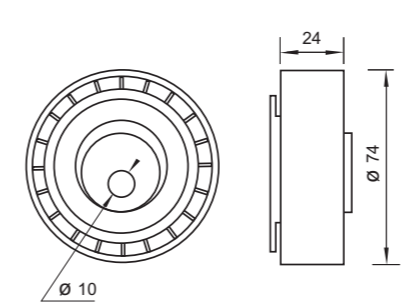
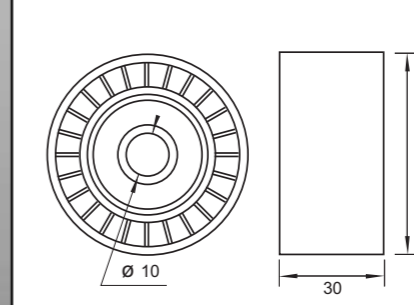
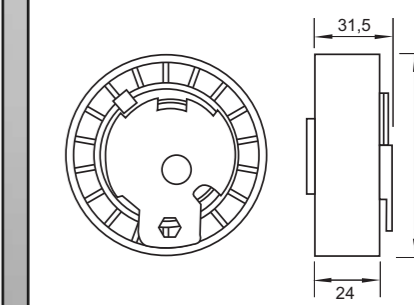
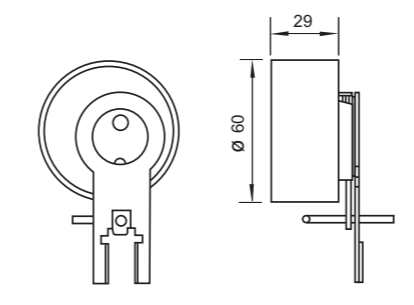
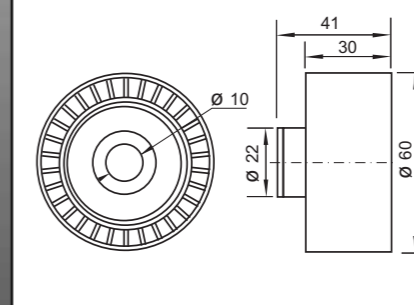
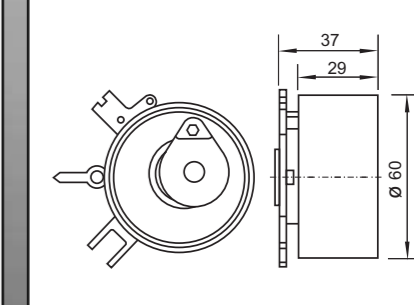
CÓDIGO CODE EM	CÓDIGO ORIGINAL ORIGINAL CODE	CÓDIGO CODE EM	CÓDIGO ORIGINAL ORIGINAL CODE	CÓDIGO CODE EM	CÓDIGO ORIGINAL ORIGINAL CODE			
			1099	1099553	1123	1099552	1915	6177882 = 6988203
			1985	1005516 = 96FF6K254AA	12157	1038384	12166	1053942
			12167	1095025=1213852	12169	1000159=1072031=1107573	12297	1104087=1111911
			12333	XS4Q6B217AD	12377	1145955	12454	YS4Q6K254AB-1215978
			12498	1145947	12507	1231978	12522	1231975

MODELO MODEL	COMB./FUEL	MOTOR ENGINE	AÑO YEAR		CÓDIGO CODE		
			DESDE SINCE	HASTA TO	FIJO FIXED	MÓVIL MOBILE	NOTA NOTE

FORD FUSION

1.4 16v	1388	N	ZETEC	10/02			12505	
1.6 16v	1596	N	ZETEC	10/02			12505	
1.4TDCi	1399	D	F6JA - C8K DV4TD	10/02		12377	12498	

FORD GALAXY

2.0 Brasil	1984	N	ADY - 2E	09/92			1805	
1.9TDI	1896	D	IZ - AHU - AFN	11/95	04/00	1128	1104	90 CV
1.9TDI	1896	D		05/00		1167	1107	116 CV
1.9TDI	1896	D	ANU - AUJ	09/96	03/00	12238	12484	
1.9TDI	1896	D	ASZ - AUJ	04/00	04/02	12238	12239	130 CV
1.9TDI	1896	D	ANU - AUJ - ASZ	05/02		12474	12458	

FORD GRANADA

1.6	1593	N	TL16 OHC	02/81	02/85		1839	
1.8	1796	N	TL18 OHC	02/81	02/85		1839	
2.0	1993	N	TL20 OHC	02/81	02/85		1839	

FORD MAVERICK

2.4 i	2389			002/93			1839	
-------	------	--	--	--------	--	--	------	--

FORD MONDEO

1° - 1.6 16v	1597	N	ZH16 ZETEC E	02/93	05/98	1904 1096	1903	
1° - 1.8 16v	1796	N	ZH18 ZETEC E	02/93	05/98	1904 1096	1903	

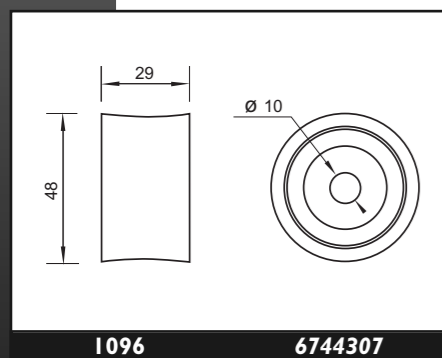

1096

6744307

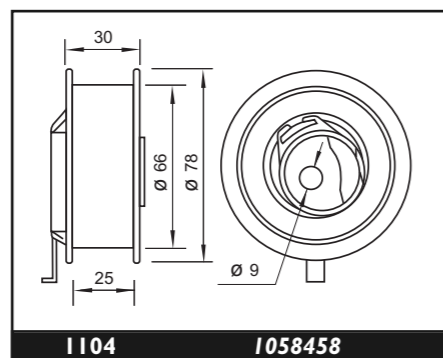

1104

1058458

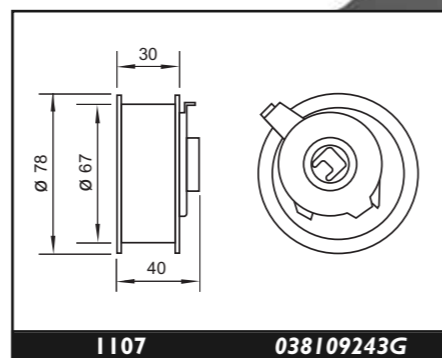

1107

038109243G

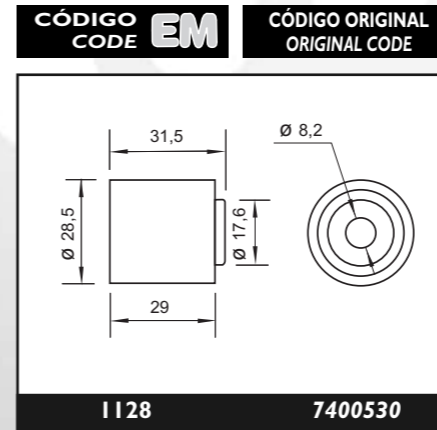

1128

7400530

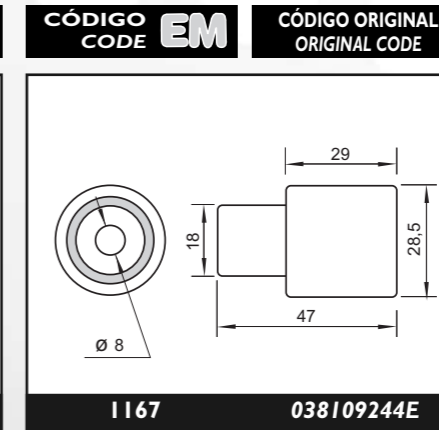

1167

038109244E

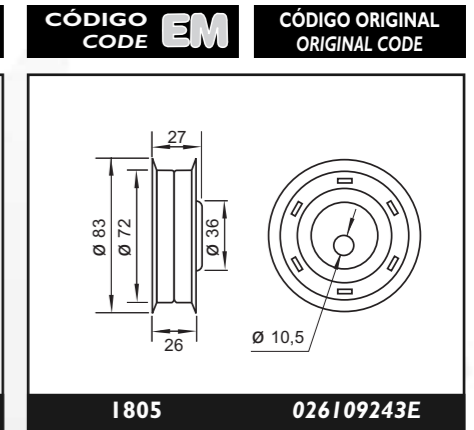

1805

026109243E

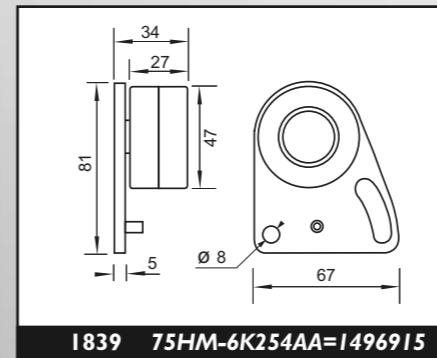

1839 75HM-6K254AA=1496915

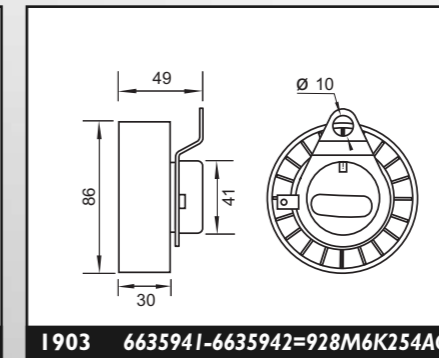

1903 6635941-6635942=928M6K254AC

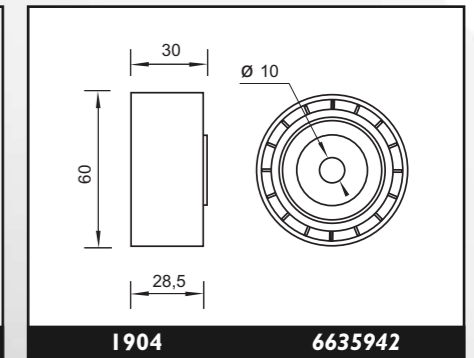

1904

6635942

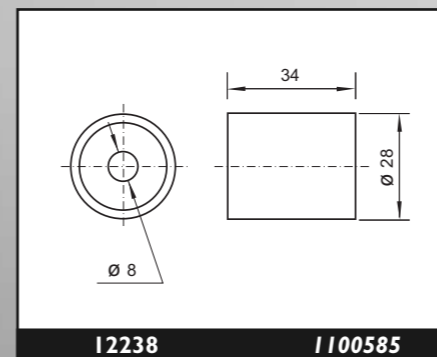

12238

1100585

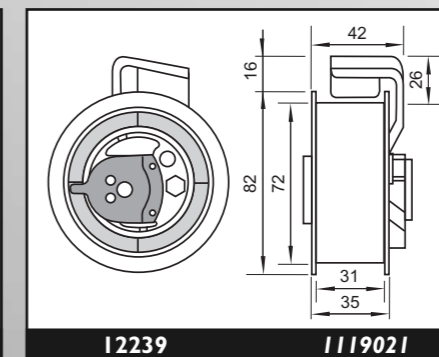

12239

1119021

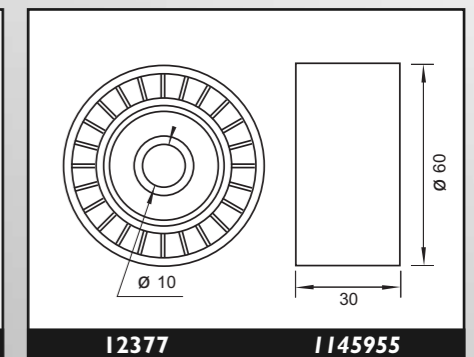

12377

1145955

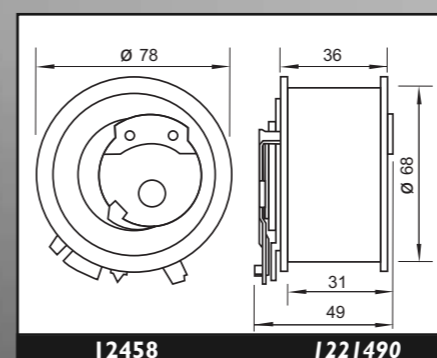

12458

1221490

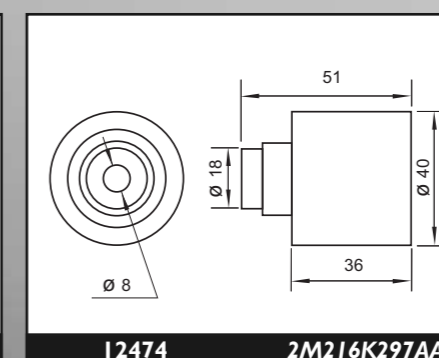

12474

2M216K297AA

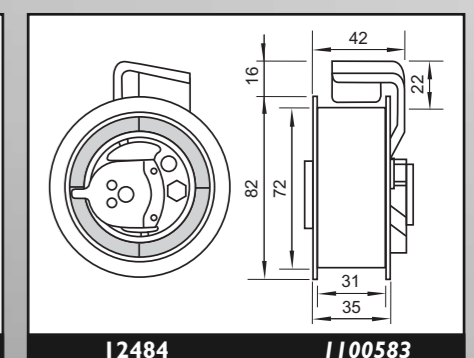

12484

1100583

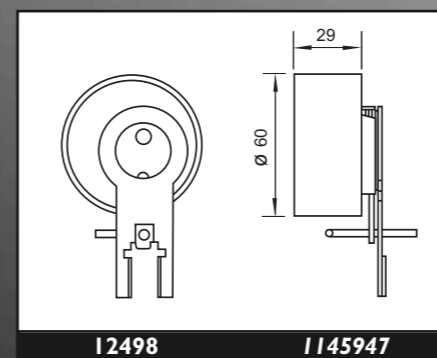

12498

1145947

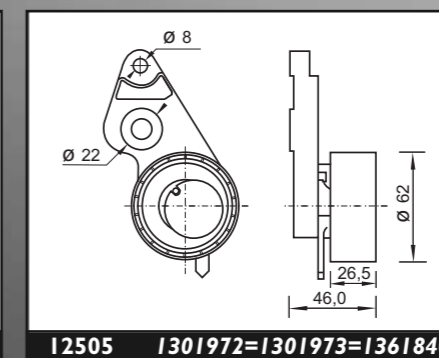

12505

1301972=1301973=1361840

MODELO MODEL	COMB./FUEL	MOTOR ENGINE	AÑO YEAR		CÓDIGO CODE			NOTA NOTE
			DESDE SINCE	HASTA TO	FIJO FIXED	MÓVIL MOBILE	CÓDIGO ORIGINAL ORIGINAL CODE	

FORD MONDEO

1° - 2.0 16v	1998	N	ZH20 ZETEC E	03/93	05/98	1904 1096	1903	
1° - 1.8 TD	1753	D	RFM - RFN	09/93	10/95	1902	12162 1915	Bomba inyectora Injection pump
1° - 1.8 TD	1753	D	RFM - RFN	11/95	08/96	1902	1985 1915	Bomba inyectora Injection pump
1° - 1.8 TD	1753	D	RFM - RFN	09/96		1123	1099 1915	Bomba inyectora Injection pump
1° - 1.8 TD	1753	D	D18TIRFN LD18TIRFN	09/88			12333 ó 12454	Man.Tens. Aut. Tens.
2° - 1.6 16v	1597	N	ZH16 ZETEC E	02/93	05/98	1904 1096	1903	
2° - 1.6 16v	1597	N	ZH16 ZETEC E	06/98	01/99	12157 1096	12169	
2° - 1.2 16v	1597	N	ZH16 ZETEC E	02/99		12157 12167	12169	
2° - 1.8 16v	1796	N	ZH18 ZETEC E	02/93	05/98	1904 1096	1903	
2° - 1.8 16v	1796	N	ZH18 ZETEC E	06/98	01/99	12157 12166	12169	
2° - 1.8 16v	1796	N	ZH18 ZETEC E	02/99		12157 12167	12169	
2° - 2.0 16v	1998	N	ZH20 ZETEC E	03/93	05/98	1904 1096	1903	
2° - 2.0 16v	1998	N	ZH20 ZETEC E	06/98	01/99	12157 12166	12169	
2° - 2.0 16v	1998	N	ZH20 ZETEC E	02/99		12167 12166	12169	
2° - 1.8 TD	1753	D	RFM - RFN	09/93	10/95	1902	12162 1915	
2° - 1.8 TD	1753	D	RFM - RFN	11/95		1902	1985 1915	
2° - 1.8 TD	1753	D	RFM - RFN	09/96		1123	1099 1915	Bomba inyectora Injection pump
2° - 1.8 TD	1753	D	Todos los tipos All the types	09/88			12333 ó 12454	Bomba inyectora Injection pump

CÓDIGO CODE	CÓDIGO ORIGINAL ORIGINAL CODE	CÓDIGO CODE	CÓDIGO ORIGINAL ORIGINAL CODE	CÓDIGO CODE	CÓDIGO ORIGINAL ORIGINAL CODE
1096	6744307	1099	1099553	1123	1099552
1902	6177884=6492482=7053802=1005823	1903	6635941-6635942=928M6K254AC	1904	6635942
1915	6177882=6988203	1985	1005516 = 96FF6K254AA	12157	1038384
12162	6178656=6497120	12166	1053942	12167	1095025=1213852
12169	1000159=1072031=1107573	12333	XS4Q6B217AD	12454	YS4Q6K254AB-1215978

MODELO MODEL	COMB./FUEL	MOTOR ENGINE	AÑO YEAR		CÓDIGO CODE			NOTA NOTE
			DESDE SINCE	HASTA TO	FIJO FIXED	MÓVIL MOBILE	EM euromotor®	

FORD ORION

1.3	1296	N	HLI3	07/83	07/90		12504	
1.4	1392	N	HLI4	03/86	12/93		1837	
1.6	1597	N	HLI6	07/83	12/93		1837	
1.6	1598	N	AB9 (Audi)	10/94			1805	
1.6 16v	1597	N	LIH - LIE - LFJ ZH ZETEC	07/90	12/93	1904 1096	1903	
1.8	1781	N	AB9 (Audi)	04/95			1805	
1.8 16v	1796	N	RDA - RQB ZH ZETEC	01/92	12/93	1904 1096	1903	
2.0	1984	N	ADY - 2E	04/95			1805	
1.8 D	1753	D	RT - RF	01/89	10/95	1902	12162 1915	Bomba inyectora Injection pump
1.8TD	1753	D	RT - RF	01/89	10/95	1902	12162 1915	Bomba inyectora Injection pump

FORD PUMA

1.4 16v	1388	N	ZHI4-FHD-FHF	01/96	02/97	12166		
1.4 16v	1388	N	ZHI4-	03/97			12297 ó 12505	
1.6 16v	1596	N	ZHI6	10/00			12297	
1.6 16v	1596	N	ZHI6-	03/97			12297 ó 12505	
1.7 16v	1679	N	ZHI7-	03/97			12297 ó 12505	

FORD SCORPIO

1.8	1796	N	REC	04/85	02/92		1839	
2.0i	1993	N	TL20	04/85	09/94		1839	

FORD SIERRA

1.3	1294	N	JCT	07/82	12/96		1839	
1.6	1593	N	TL16	08/82	02/93		1839	
1.8	1796	N	TL18	08/82	02/93		1839	

CÓDIGO
CODE

CÓDIGO ORIGINAL
ORIGINAL CODE

CÓDIGO
CODE

CÓDIGO ORIGINAL
ORIGINAL CODE

CÓDIGO
CODE

CÓDIGO ORIGINAL
ORIGINAL CODE

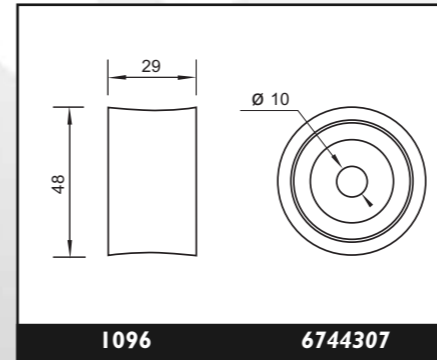

1096

6744307

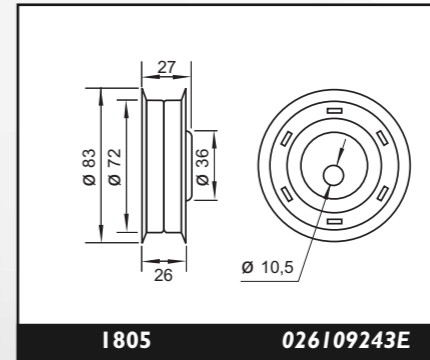

1805

026109243E

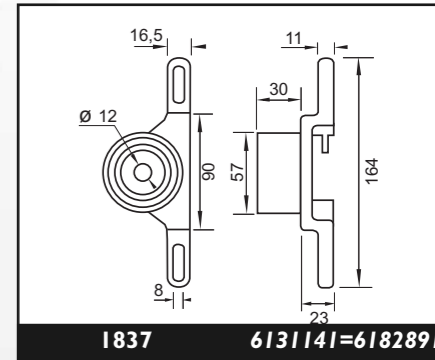

1837

6131141=6182891

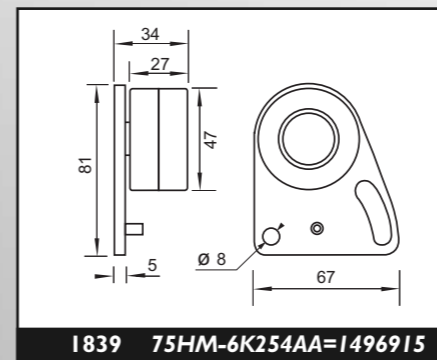

1839

75HM-6K254AA=1496915

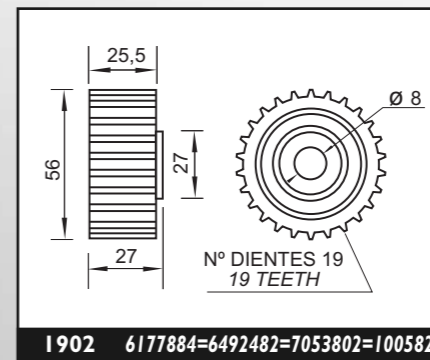

1902

6177884=6492482=7053802=1005823

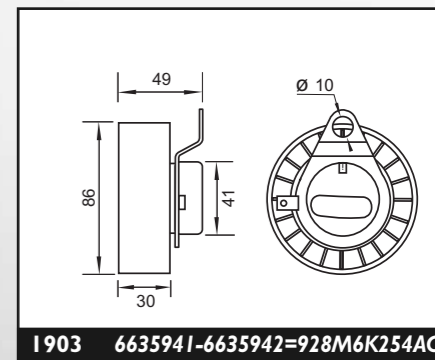

1903

6635941-6635942=928M6K254AC

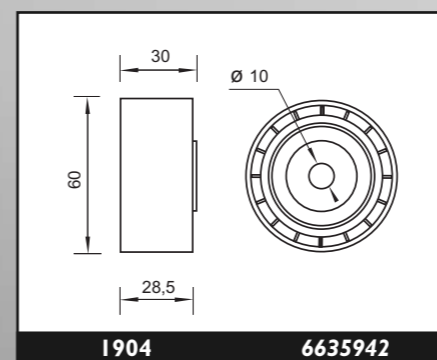

1904

6635942

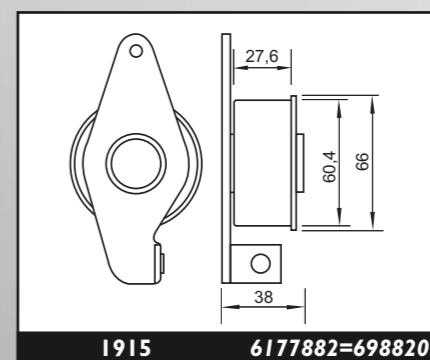

1915

6177882=6988203

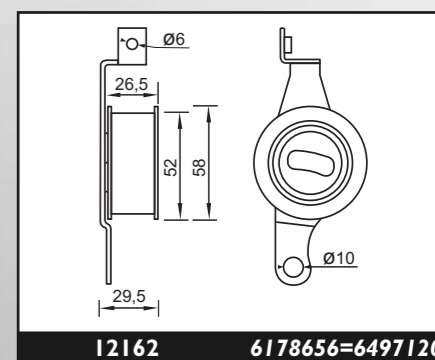

12162

6178656=6497120

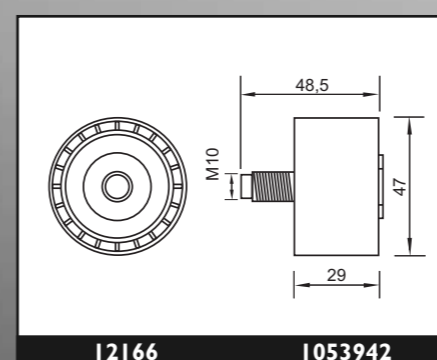

12166

1053942

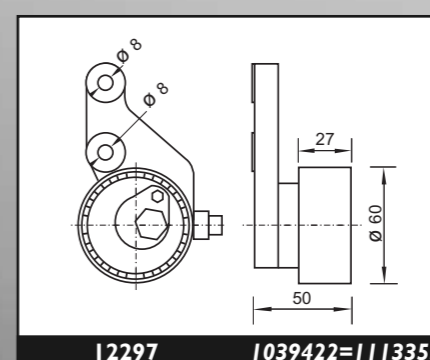

12297

1039422=1113355

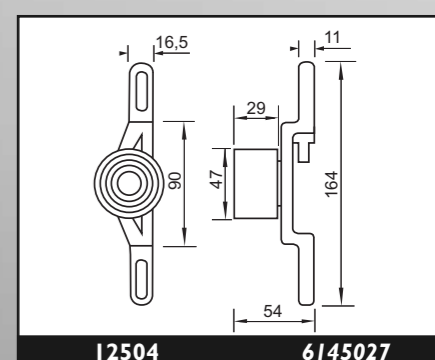

12504

6145027

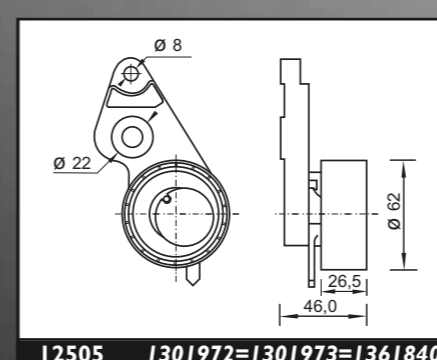

12505

1301972=1301973=1361840

MODELO MODEL	MOTOR ENGINE	AÑO YEAR		CÓDIGO CODE			NOTA NOTE
		DESDE SINCE	HASTA TO	FIJO FIXED	MÓVIL MOBILE	EM euromotor®	

FORD SIERRA

1.8	1796	N	TL18H	08/82	02/93		12504	
2.0	1993	N	TL20	08/82	02/93		1839	
2.3	2286	N	TL23				E1451	
1.8 D	1753	D	RFA-RFB-RFL	08/88	02/93	1902	12162 1915	Bomba inyectora Injection pump
1.8 TD	1753	D	RFA-RFB-RFL	08/88	02/93	1902	12162 1915	Bomba inyectora Injection pump

FORD TAUNUS

2.0	1993	N	TL20	04/85			1839	
2.3	2286	N	TL23	04/85			E1451	

Utilitarios

FORD COURIER

1.4 16v	1388	N	FXDA - FXDB FXDG - FXDD	09/97			12297	
1.8 D	1753	D	RT	09/96		1123	1915 1099	
1.8 Di	1753	D	1.8 Turbodiesel	04/00			12454	Bomba inyectora Injection pump

FORD ESCORT VAN

1.8 D	1753	D	RT - RF	01/89	11/95	1902	12162 1915	Bomba inyectora Injection pump
1.8 D	1753	D	RT - RF - RVA	12/95	01/97	1902	1985 1915	Bomba inyectora Injection pump
1.8 D	1753	D	RT - RF - RVA	02/97		1123	1099 1915	Bomba inyectora Injection pump
1.8 TD Van	1753	D	RT - RF	01/89	11/95	1902	12162 1915	Bomba inyectora Injection pump
1.8 TD Van	1753	D	RT - RF - RVA	12/95	01/97	1902	1985 1915	Bomba inyectora Injection pump
1.8 TD Van	1753	D	RT - RF - RVA	02/97		1123	1099 1915	Bomba inyectora Injection pump

CÓDIGO CODE	EM	CÓDIGO ORIGINAL ORIGINAL CODE	CÓDIGO CODE	EM	CÓDIGO ORIGINAL ORIGINAL CODE	CÓDIGO CODE	EM	CÓDIGO ORIGINAL ORIGINAL CODE
1099		1099553	1123		1099552	1839		75HM-6K254AA=1496915
1902		6177884=6492482=7053802=1005823	1915		6177882=6988203	1985		1005516 = 96FF6K254AA
12162		6178656=6497120	12297		1104087=1111911	12454		YS4Q6K254AB-1215978
12504		6145027	E1451		D42E 6K254AD			

MODELO MODEL	COMB./ FUEL	MOTOR ENGINE	AÑO YEAR		CÓDIGO CODE			NOTA NOTE
			DESDE SINCE	HASTA TO	FIJO FIXED	MÓVIL MOBILE	EM euromotor®	

FORD P100

1.6	1598	N	LCR	04/82	09/87		1839	
2.0	1993	N	NAE	10/87			1839	
1.8TD	1753	D	RFA	10/87	02/92	1902	12162 1915	Bomba inyectora Injection pump

FORD RANGER Pickup

2.5TD	2498	D	2.5 Maxion	04/97	06/01	1892	1968	Engran. cigueñal Crankshaft gear E1621
2.8TDI	2785	D	2.8 Maxion	07/01	09/05	1892	1968	Engran. cigueñal Crankshaft gear E1621
3.0TDI	2968	D	3.0 Maxion	10/05		1892	1968	Engran. cigueñal Crankshaft gear E1621

FORD TRANSIT

1.6	1598	N	4RB-LAT-	04/825	09/92		1839	
2.0	1993	N	4RC-VAV-NAT-	1978	09/92		1839	
2.4 D	2400	D	4AA-2401	09/71	1990		12168	
2.5 D	2496	D	York-4AB-4CA-	1984	09/92		1842	
2.5TD	2496	D	York-4AB-4CA-	1984	09/92		1842	

FORD CONNECT

1.8	1796	N		05/02		12157 12167	12169	
1.8 DI	1753	D	TC7-	05/02			12333	Bomba inyectora Injection pump

CÓDIGO CODE	EM	CÓDIGO ORIGINAL ORIGINAL CODE	CÓDIGO CODE	EM	CÓDIGO ORIGINAL ORIGINAL CODE	CÓDIGO CODE	EM	CÓDIGO ORIGINAL ORIGINAL CODE
1839	75HM-6K254AA=1496915		1842	6121753=6121754		1892	LHV 100150	
1902	6177884=6492482=7053802=1005823		1915	6177882=6988203		1968	LHP 100680	
12157	1038384		12162	6178656=6497120		12167	1095025=1213852	
12168	1500004		12333	XS4Q6B217AD		E1621	BGIT-6312AA	

EM euromotor®

VERSION PDF 2010



Ø18

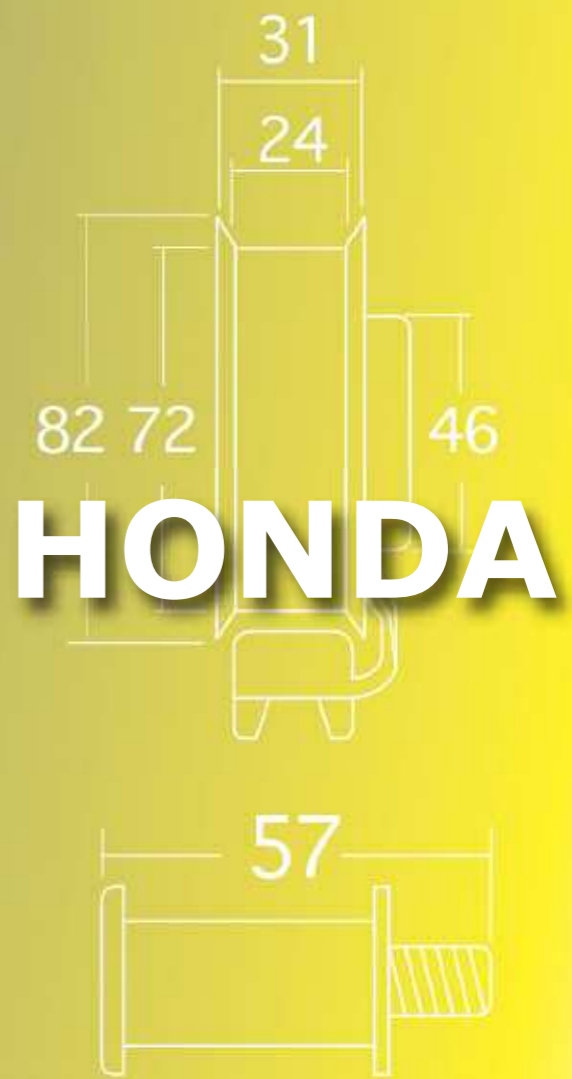

HONDA





MODELO MODEL	COMB./FUEL	MOTOR ENGINE	AÑO YEAR		CÓDIGO CODE EM euromotor®		
			DESDE SINCE	HASTA TO	FIJO FIXED	MÓVIL MOBILE	NOTA NOTE

HONDA ACCORD

1.6	1602	N	EL	01/79	09/83		12211	
1.6	1598	N	EZ-A16A1SOHC	09/83	02/89		12218	
1.6	1590	N	D16B6	10/98			12509	
1.8	1829	N	ET1	09/83	10/85		12218	
1.8	1850	N	F18B2	10/98			1178 1905	
1.9	1850	N	F18A3	02/96	10/98		1905	
2.0 16v	1955	N	A20A1/2/3/4	11/85	12/89		12218	
2.0	1997	N	F20A2/4/6/8- F20Z1/2-F20B3/6	01/90			1178 1905	
2.2	2156	N	F22A3-F22B5-F22Z2	01/90	10/98		1178 1905	
2.3	2259	N	H23A3	03/93	01/96		1178 1905	

HONDA CIVIC

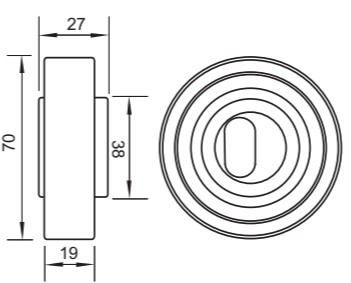
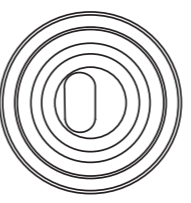
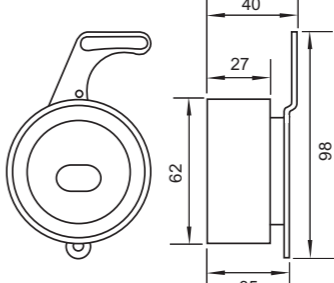
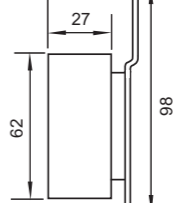
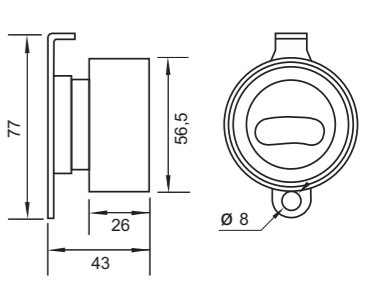
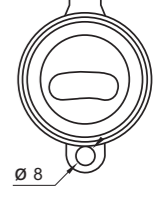
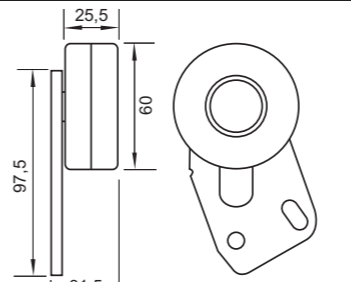
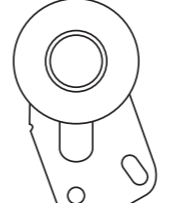
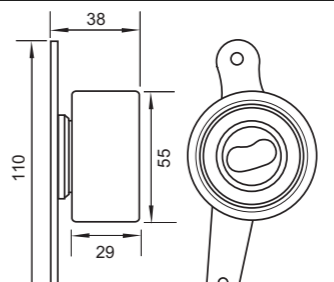
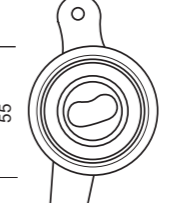
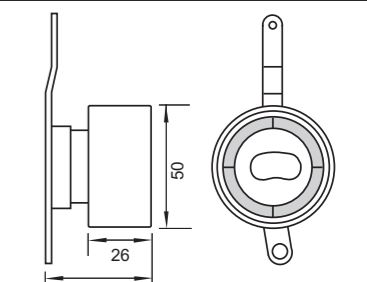
1.2	1187	N	ZA2-EV2-EW4	09/83	10/87		12511	
1.3	1342	N	EV2	10/83	10/87		12511	
1.3	1343	N	D13B1-D13B2	10/87	11/95		1927	
1.3 16v	1343	N	D13B1-D13B2	10/87	11/95		1927	
1.4	1396	N	D14A1-D14A2/5	10/87	01/97		1927	
1.4 16v	1396	N	D14A3/4/7/8	11/95			12509	
1.5	1488	N	EW2-EW3-EW4	10/83	10/87		12511	
1.5	1493	N	D15Z3/6/8	01/94			12509	
1.5 16v	1493	N	D15B2-D15Z1	10/88	11/95		12509	
1.6	1590	N	D16Y5	11/95			12509	
1.6 16v	1590	N	D16A6/7-D16Z2/6- D16Y3	10/87	01/97		1927	
1.6 16v	1590	N	D16B2	01/97			12509	

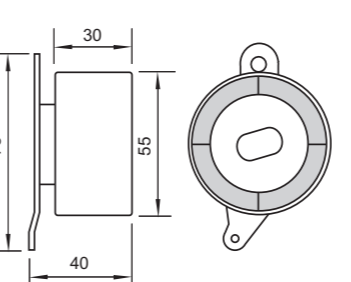
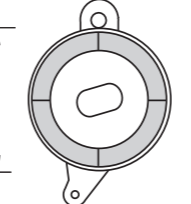
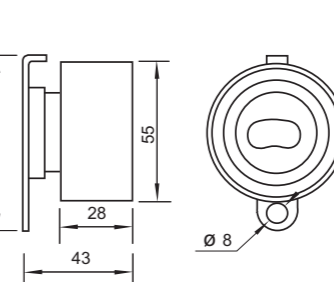
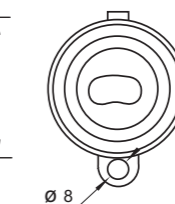
CÓDIGO CODE EM	CÓDIGO ORIGINAL ORIGINAL CODE	CÓDIGO CODE EM	CÓDIGO ORIGINAL ORIGINAL CODE	CÓDIGO CODE EM	CÓDIGO ORIGINAL ORIGINAL CODE
					
1178	13404-PT0-004	1905	14510-PT0-004	1927	14510-PM7-004
					
12211	14510-689-003=14510-PCI-003	12218	14510-PD2-003	12509	14510-P08-003
					
12510	14510-PR3-004	12511	14510-PE0-005		

MODELO MODEL	COMB./FUEL	MOTOR ENGINE	AÑO YEAR		CÓDIGO CODE		
			DESDE SINCE	HASTA TO	FIJO FIXED	MÓVIL MOBILE	NOTA NOTE

HONDA CIVIC

1.6 16v V-tec	1595	N	BI6A1-BI6A2	10/89	11/95		12510
1.6 16v V-tec-E	1590	N	DI6Y2-DI6Z6	10/91	01/97		12509
1.6 Vti	1595	N	BI6A2	11/95			12510
1.8 16v	1797	N	DI8C4	01/97			12509
1.8 16v	1797	N	BI8C4	01/98			12510
1.7 CDi	1686	D	Motor ISUZU Engine	02/01		1878	12457
Aerodeck - 1.4 16v	1396	N	DI4A7-DI4A8	01/98			12509
Aerodeck - 1.5 16v	1493	N	DI5Z8	01/98			12509
Aerodeck - 1.6 16v	1595	N	DI6B2	01/98			12509
Aerodeck - 1.8 16v	1797	N	BI8C4	01/98			12510
Shuttle - 1.5	1488	N	EW2	10/83	10/87		12511
Shuttle - 1.5 16v	1493	N	DI5B2	01/88	11/91		12509
Shuttle - 1.6 16v	1590	N	DI6A6	01/88	02/95		12218

HONDA CONCERTO

1.4	1396	N	DI4A1	01/89	02/95		1927
1.4 16v	1396	N	DI4A8	01/89	02/91		12509
1.5	1493	N	DI5B2	08/89	03/95		1927
1.6 16v	1590	N	DI6A8	01/89	02/91		12509
1.6 16v	1590	N	DI6Z2 - A8	08/89	03/95		1927

HONDA CRV

2.0 16v	1958	N	B20B	01/95	12/99		12510
---------	------	---	------	-------	-------	--	-------

HONDA CRX

1.3	1342	N	EV2	10/83	10/87		12511
1.5	1488	N	EW3	10/83	10/86		12511

CÓDIGO CODE	EM	CÓDIGO ORIGINAL ORIGINAL CODE	CÓDIGO CODE	EM	CÓDIGO ORIGINAL ORIGINAL CODE	CÓDIGO CODE	EM	CÓDIGO ORIGINAL ORIGINAL CODE
	1878	Y70112730		1927	14510-PM7-004		12218	14510-PD2-003
	12457	5636739		12509	14510-P08-003		12510	14510-PR3-004
	12511	14510-PE0-005						

MODELO MODEL	COMB./FUEL	MOTOR ENGINE	AÑO YEAR		CÓDIGO CODE		
			DESDE SINCE	HASTA TO	FIJO FIXED	MÓVIL MOBILE	NOTA NOTE

HONDA CRX

1.6 16v	1590	N	DI6Z5-DI6A9	10/87	02/92		1927	
1.6 V-tec	1595	N	B16A1	10/89	02/92		12510	
1.6 Esi	1590	N	DI6Z6	03/92			12509	
1.6 VTi	1595	N	B16A2	03/92			12510	

HONDA FIT

1.4 8v	1339	N	DI4A8				12218	
1.5 16v V-tec	1496	n	DI5Z6				12218	

HONDA HRV

1.6 16v	1590	N	DI6W1	03/99			12509	
---------	------	---	-------	-------	--	--	-------	--

HONDA INTEGRA

1.5	1488	N	EW	02/86	08/87		12511	
1.6	1590	N	ZC	04/89	10/91		1927	
1.8 Type-R	1797	N	B18C6	01/97			1927	

HONDA LOGO

1.3	1342	N	DI3B7	03/99			12509	
-----	------	---	-------	-------	--	--	-------	--

HONDA ODYSSEY

2.2	2156	N	F22B				1178 1905	
-----	------	---	------	--	--	--	--------------	--

HONDA PASSPORT

2.6	2600	N	4ZE1	11/93			12282	
-----	------	---	------	-------	--	--	-------	--

HONDA PRELUDE

1.6	1602	N	EL	11/78	10/82		12211	
1.8 EX	1829	N	ET2-ET4	11/83	04/97		12218	
2.0	1958	N	B20A3-B20A4	04/87	01/92		12219	

CÓDIGO CODE	EM	CÓDIGO ORIGINAL ORIGINAL CODE	CÓDIGO CODE	EM	CÓDIGO ORIGINAL ORIGINAL CODE	CÓDIGO CODE	EM	CÓDIGO ORIGINAL ORIGINAL CODE
1178		I3404-PT0-004	1905		I4510-PT0-004	1927		I4510-PM7-004
12211		I4510-689-003=I4510-PCI-003	12218		I4510-PD2-003	12219		I4510-PH3-003=I4510-PK1-004
12282		8-4472-3-249-1=8-94472-349-1	12509		I4510-P08-003	12510		I4510-PR3-004
12511		I4510-PE0-005						

MODELO MODEL	MOTOR ENGINE	AÑO YEAR		CÓDIGO CODE			MÓVIL MOBILE	NOTA NOTE
		DESDE SINCE	HASTA TO	FIJO FIXED	EM euromotor®			

HONDA PRELUDE

2.0 16v	1958	N	B20A1/5/7/9	04/86	01/92		12219	
2.0 16v	1997	N	F20A4	02/92			1178 1905	
2.3 16v	2259	N	H23A2	02/92	09/96		1178 1905	

HONDA QUINTET

1.6	1602	N	EL	02/80	12/84		12211	
-----	------	---	----	-------	-------	--	-------	--

HONDA SHUTTLE

2.2 16v	2156	N	F22B8	10/94	02/98		1178 1905	
2.3 16v	2254	N	F23A7	03/98			1178 1905	

CÓDIGO CODE	EM	CÓDIGO ORIGINAL ORIGINAL CODE	CÓDIGO CODE	EM	CÓDIGO ORIGINAL ORIGINAL CODE	CÓDIGO CODE	EM	CÓDIGO ORIGINAL ORIGINAL CODE
1178		13404-PT0-004	1905		14510-PT0-004	12211		14510-689-003=14510-PC1-003
12219		14510-PH3-003=14510-PK1-004						

EM euromotor[®]

VERSION PDF 2010

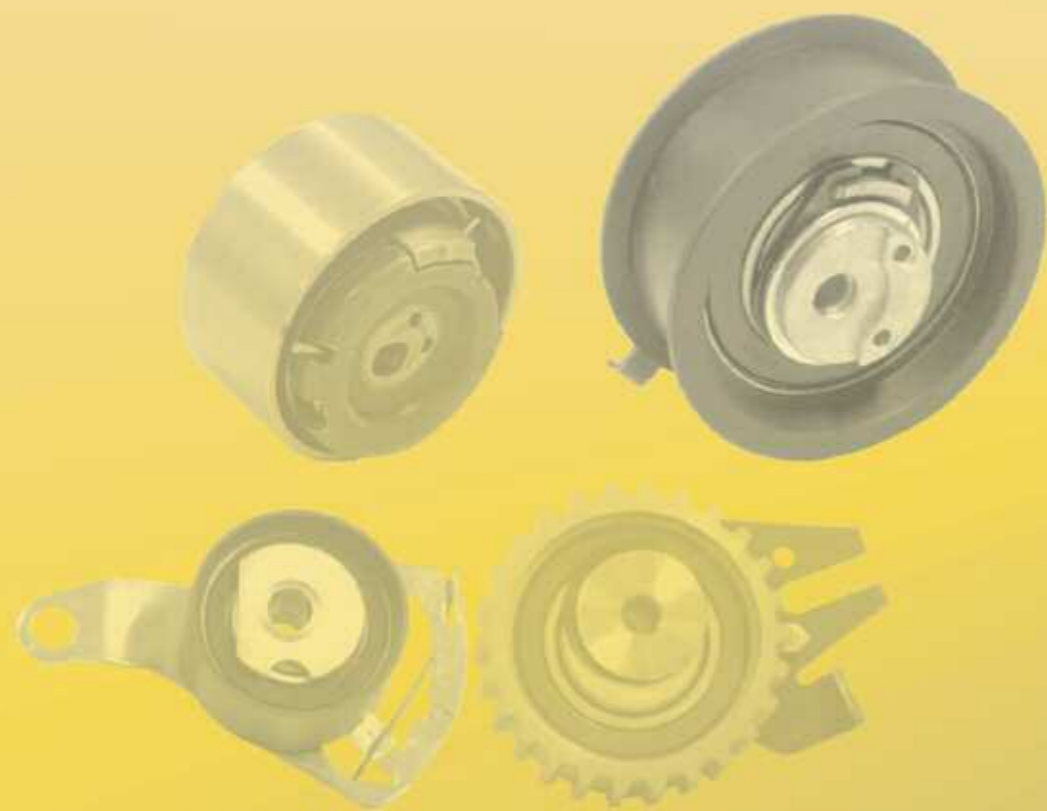

Ø18

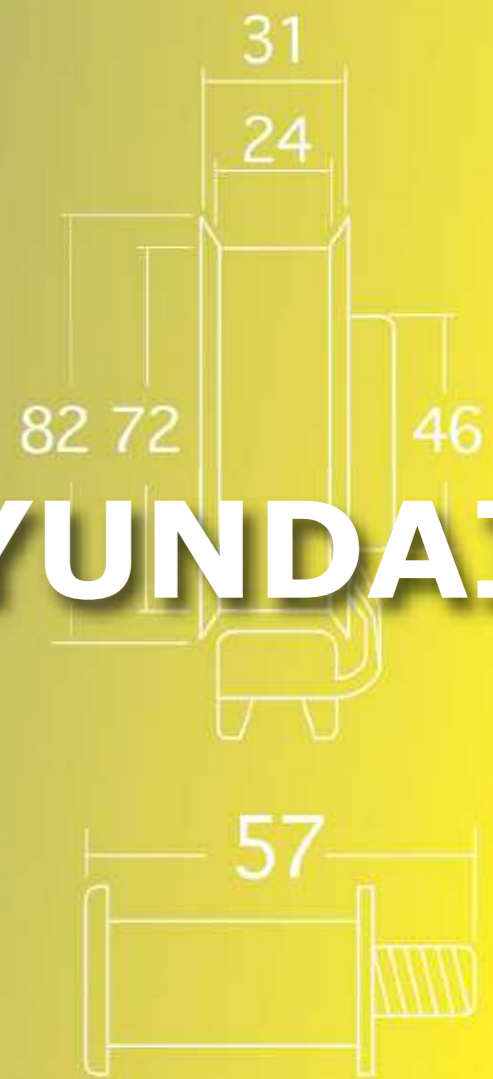

HYUNDAI



MODELO MODEL	COMB./FUEL	MOTOR ENGINE	AÑO YEAR		CÓDIGO CODE		
			DESDE SINCE	HASTA TO	FIJO FIXED	MÓVIL MOBILE	NOTA NOTE

HYUNDAI ACCENT

1.3	1341	N	G4EH	10/94	01/00		12224
1.3 12v	1341	N			02/00		12224
1.5	1495	N	G4EK	10/94	01/00	12514	12224

HYUNDAI ATOS y ATOZ

0.8	800	N		09/97	12/00		12277
Prime 1.0 12v	999	N	G4HC	02/98	12/03		12277
Prime 1.1 12v	1086	N	G4HG	01/04			12277

HYUNDAI AVANTE

1.5	1495	N				12514	12224
-----	------	---	--	--	--	-------	-------

HYUNDAI COUPE

1.6 16v	1599	N	4G6I	08/96		12516	12195
2.0 16v	1975	N	G4GF	08/96		1055	12194 12206 12401

HYUNDAI ELANTRA

1.5	1468	N	G4DJ	12/90	09/94	12514	12400
1.6	1596	N	G4CR	07/92	09/94	1055	12194 12206 12401
1.8	1836	N	G4CN	06/92	09/94	1055	12194 12206 12401
1.8	1599	N	G4GB-G	09/00		12516	12195
2.0	1975	N	G4GC-XD	09/00		1055	12194 12206 12401
2.0 CRDI	1991	D	D4-EA	06/01		12515	12513

HYUNDAI EXCEL

1.3	1300	N	G4DG	08/89	07/94		12400
1.5	1500	N	G4DJ	08/89	07/94	12514	12400

CÓDIGO CODE	EM	CÓDIGO ORIGINAL ORIGINAL CODE	CÓDIGO CODE	EM	CÓDIGO ORIGINAL ORIGINAL CODE	CÓDIGO CODE	EM	CÓDIGO ORIGINAL ORIGINAL CODE
1055		24810-33021	12194		24450-33010=24410-32553	12195		24410-23011 = 24410-23400 = 24410-37100
12206		23357-33120	12224		24410-22020=24410-26000	12277		24410-02510=24410-02550
12400		24410-21000 = 24410-21010	12401		23357-32000=23357-32010= 23357-32020=2357-32030=2357-32040	12513		24410-27000
12514		24810-26010 = 24810-26020	12515		244140-27000 REP	12516		24810-23011 = 24810-23500

MODELO MODEL	G	COMB./FUEL	MOTOR ENGINE	AÑO YEAR		CÓDIGO CODE		
				DESDE SINCE	HASTA TO	FIJO FIXED	MÓVIL MOBILE	NOTA NOTE

HYUNDAI GETZ

1.1	1086	N	G4HG	09/02			12277
1.3	1341	N	G4EA	09/02			12194
1.6	1599	N	G4EDG	09/02		12514	12224
1.5 CRDi	1496	D	D3EA	03/03		12515	12513

HYUNDAI H1

2.4	2351	N	G4CS	03/00			12401 12416
2.5 TD	2476	D	SVX -HSV D4BF - D4BH	03/00			1061 1184

HYUNDAI LANDRA

1.5	1468	N	G15B - G4DJ	10/90	11/95	12514	12400
1.5 12v	1468	N	G4EK	10/90	12/00	12514	12224
1.6	1596	N	G4CR	10/90	11/95	1055	12194 12206
1.6	1596	N	G4CR - 4G61	12/95	12/00	12516	12195
1.8	1836	N	G4CN	10/90	11/95	1055	12401 12206 12194
1.8	1836	N	G4GM	12/95	12/00	12516	12195
2.0	1975	N	G4GF	08/96		1055	12401 12206 12194
1.9 D	1905	D	XUD9	03/98		1900	1901

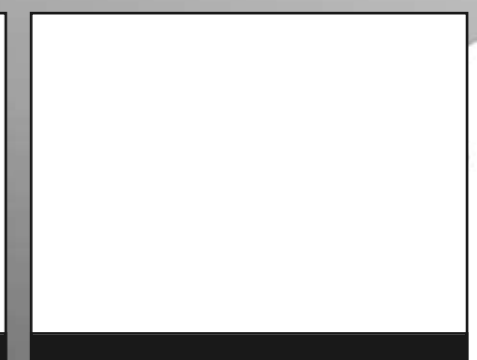
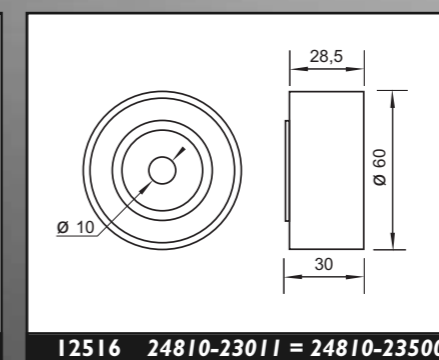
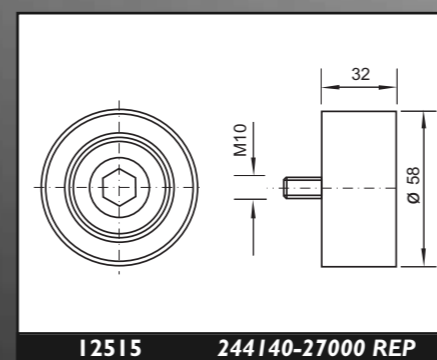
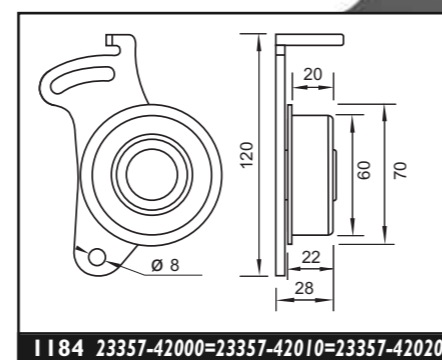
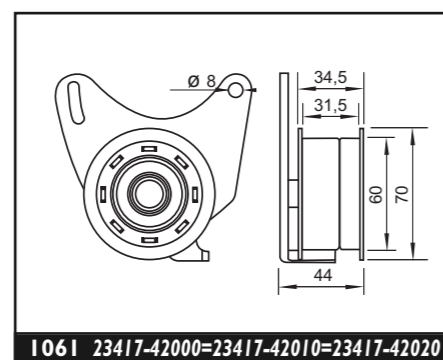
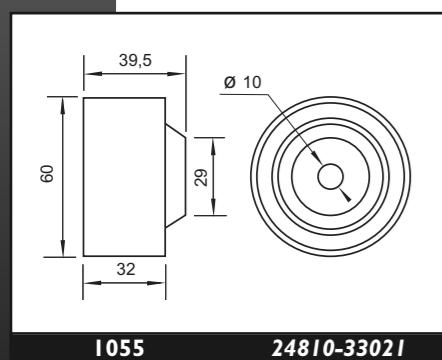
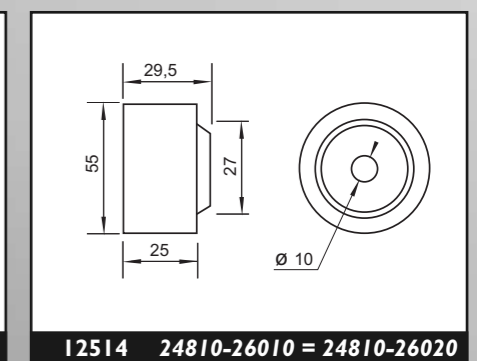
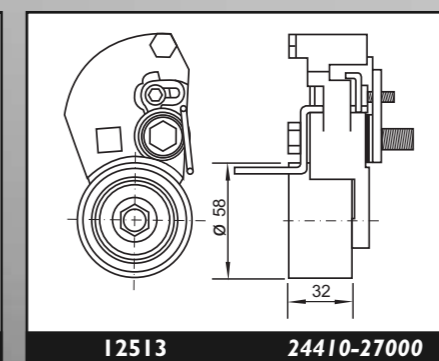
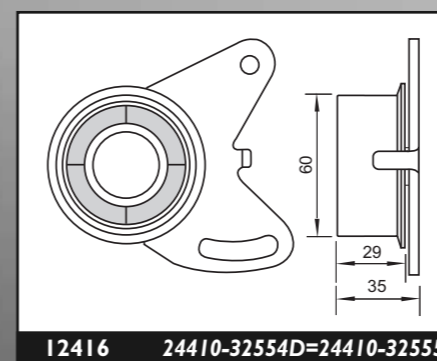
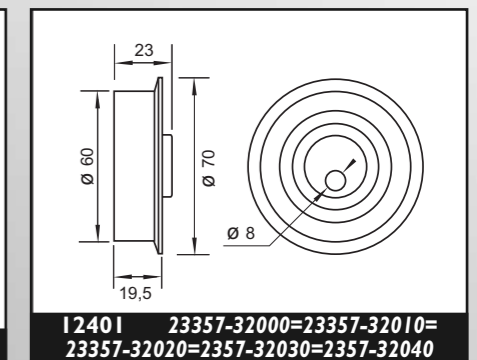
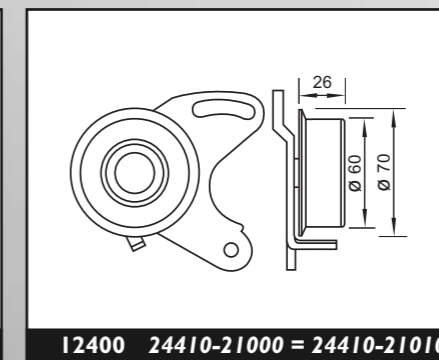
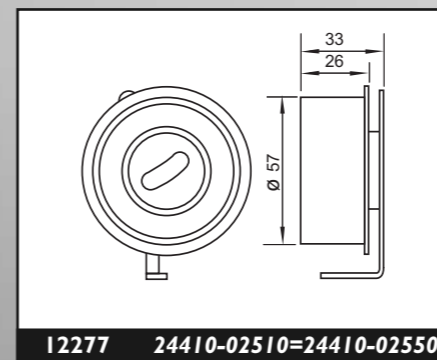
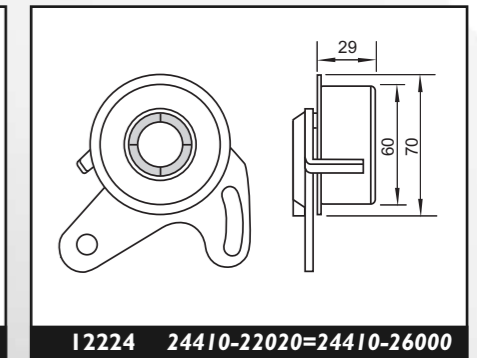
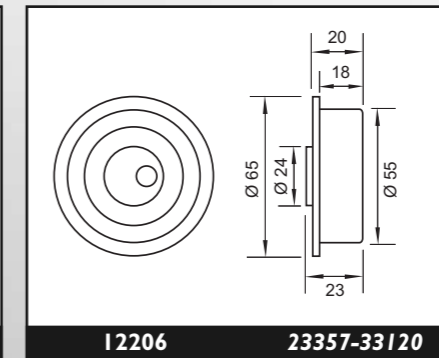
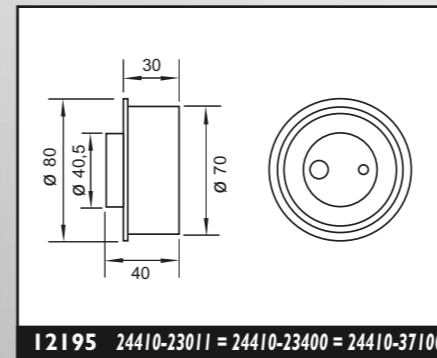
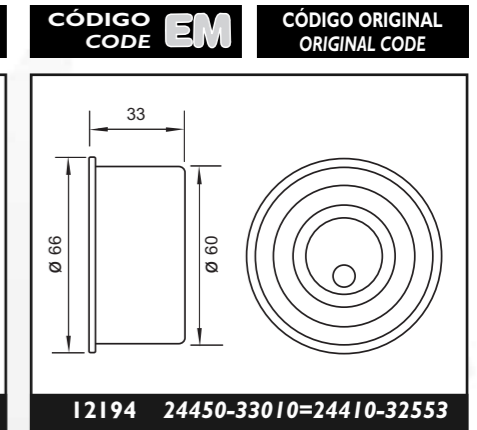
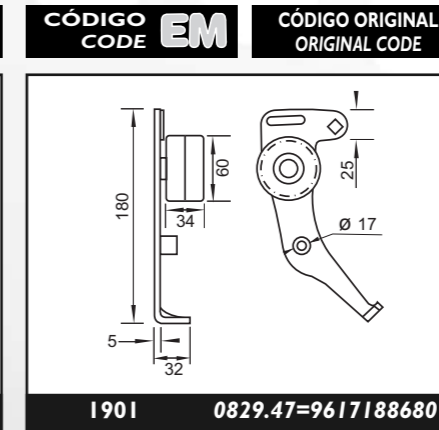
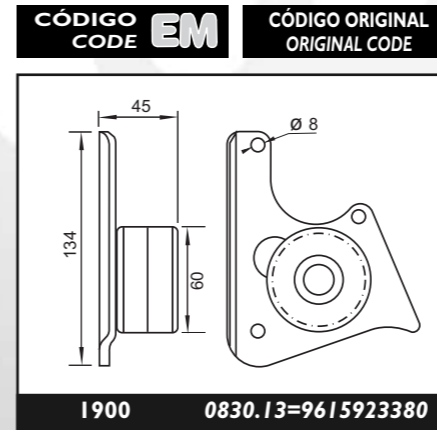

MODELO MODEL	COMB. / FUEL	MOTOR ENGINE	AÑO YEAR		CÓDIGO CODE		
			DESDE SINCE	HASTA TO	FIJO FIXED	MÓVIL MOBILE	NOTA NOTE

HYUNDAI MATRIX

1.6	1599	N	G4D	06/01		12514	12224	
1.8	1795	N	G4GB	06/01		12516	12195	
1.5 CRDI	1496	D	D3-EA	10/01		12515	12513	

HYUNDAI PONY

1.3	1298	N	G13B	10/85	09/89		12400	
1.3	1299	N	G4DG	10/89	01/94	12514	12400	
1.5	1468	N	G4DJ - G15B	10/85	09/89	12514	12400	
1.5	1468	N	G4DJ - G15B	10/89	01/94	12514	12400	
1.5	1495	N	G4EK	02/94	01/00	12514	12224	

HYUNDAI SANTAMO

2.0 16v	1997	N	GC4P-GC4P-D	07/93			12401 12416	
2.0 16v	1997	N	GC4P-DM GC4P-U	05/91		1055	12206 12194	

HYUNDAI SCOUPE

1.5	1468	N	G4DJ - G15B	02/90	05/96		12400	
1.5	1495	N	G4EK - G4EK - TC	04/91	05/96	12514	12224	
1.5 Turbo	1495	N	G4EK - G4EK - TC	04/91	05/96		12224	

HYUNDAI SONATA

1.8 i	1836	N	G4CM -	01/88	11/93		12305 12401	
1.8 i	1836	N	G4CM -	12/93	10/95		12416 12401	
2.0 i	1975	N	G4CP - G4CPU	09/88	12/93		12305 12401	
2.0 i	1975	N	G4CP - G4CPU	01/94	11/98		12416 12401	
2.0 16v	1975	N	G4CP - G4CD	01/91	11/98	1055	12194 12206	

CÓDIGO
CODE

EM

CÓDIGO ORIGINAL
ORIGINAL CODE

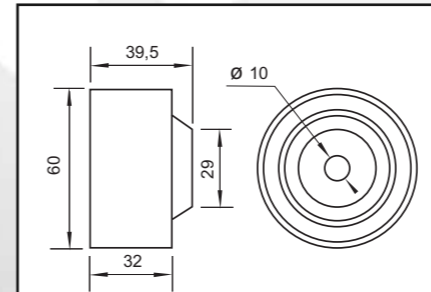

1055

24810-33021

CÓDIGO
CODE

EM

CÓDIGO ORIGINAL
ORIGINAL CODE

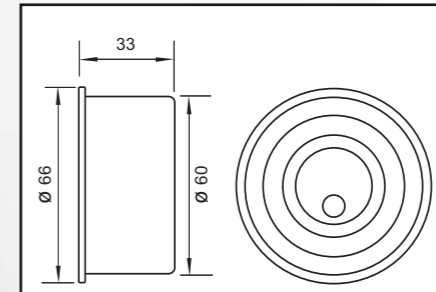

12194

24450-33010=24410-32553

CÓDIGO
CODE

EM

CÓDIGO ORIGINAL
ORIGINAL CODE

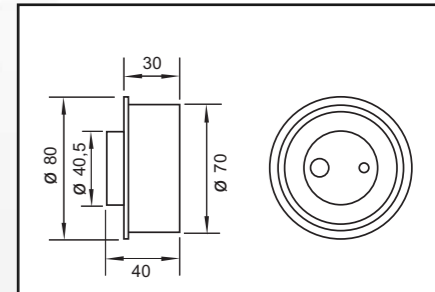

12195 24410-23011 = 24410-23400 = 24410-37100

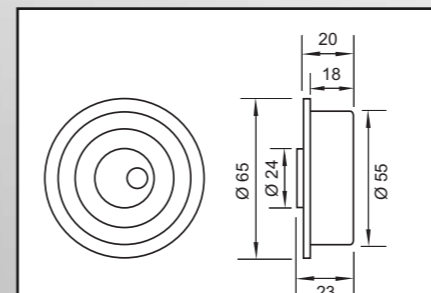

12206

23357-33120

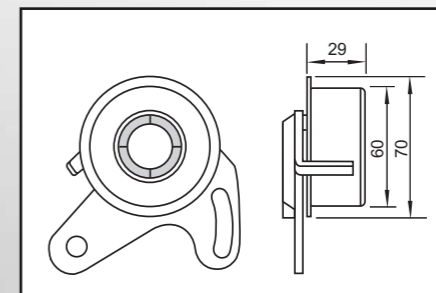

12224

24410-22020=24410-26000

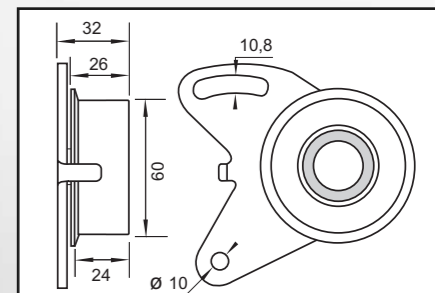

12305 24410-32000=24410-32010=24410-32020

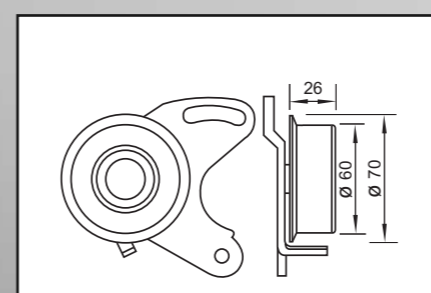

12400 24410-21000 = 24410-21010

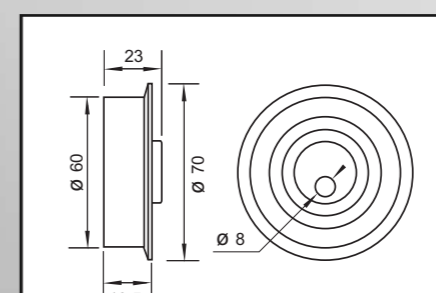

12401 23357-32000=23357-32010=
23357-32020=2357-32030=2357-32040

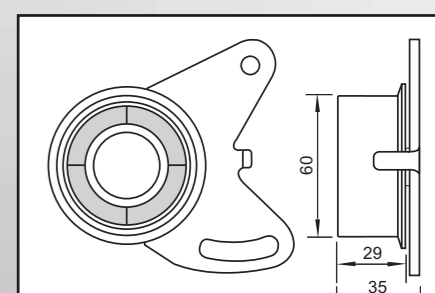

12416 24410-32554D=24410-32555

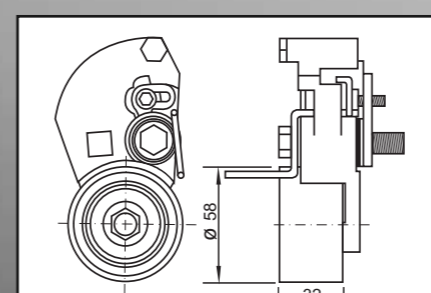

12513

24410-27000

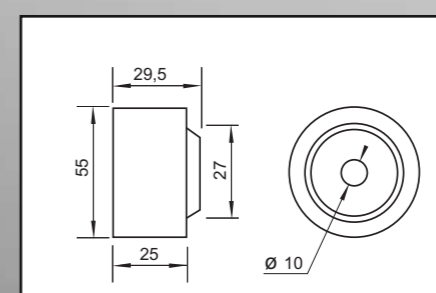

12514

24810-26010 = 24810-26020

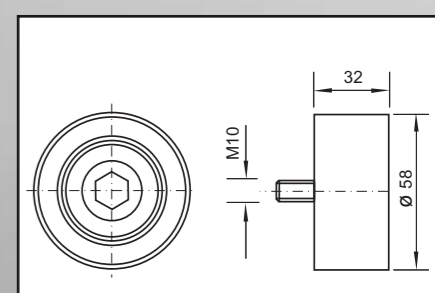

12515

244140-27000 REP

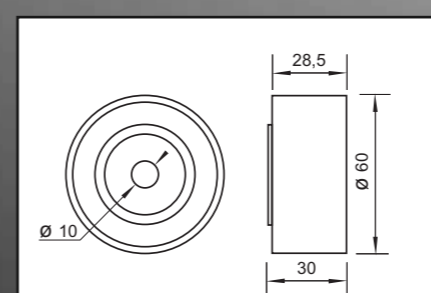

12516 24810-23011 = 24810-23500

MODELO MODEL	AÑO YEAR	MOTOR ENGINE	CÓDIGO CODE		FIJO FIXED	MÓVIL MOBILE	NOTA NOTE
			DESDE SINCE	HASTA TO			

HYUNDAI SONATA

2.0 16v	1975	N	G4JP - EF - G4JP - EG	12/98		12404	12194 12206
2.4	2351	N	Y2	03/98			12305 12401
3.0	2972	N	G6AT	09/88	05/98		12227

HYUNDAI SONICA

1.8	1796	N		1992		1055	12194 12206 12401
2.0	1797	N	G4	1992		12404	12194 12206 12401
2.0 16v	1997	N		1992		1906 1906	1100

HYUNDAI TRAJET

2.0 16v	1997	N		03/00		1906 1906	1100
2.0 CRDI	1991	D		04/01		12515	12513

Utilitario

HYUNDAI H100

2.4	2351	N		07/93			12401 12416
2.5 D	2476	D	D4BA -D4BX	07/93			1061 1184
2.5 TD	2476	D	D4BA -D4BX	07/93			1061 1184

CÓDIGO CODE	EM	CÓDIGO ORIGINAL ORIGINAL CODE	CÓDIGO CODE	EM	CÓDIGO ORIGINAL ORIGINAL CODE	CÓDIGO CODE	EM	CÓDIGO ORIGINAL ORIGINAL CODE
1055		24810-33021	1061		23417-42000=23417-42010=23417-42020	1100		90153125=9157004
1184		23357-42000=23357-42010=23357-42020	1906		90530126	12194		24450-33010=24410-32553
12206		23357-33120	12227		24410-35010=24410-35020	12305		24410-32000=24410-32010=24410-32020
12401		23357-32000=23357-32010=23357-32020=2357-32030=2357-32040	12404		24450-38010=24450-38011	12416		24410-32554D=24410-32555
12513		24410-27000	12515		244140-27000 REP			

MODELO MODEL	COMB./ FUEL	MOTOR ENGINE	AÑO YEAR		CÓDIGO CODE			MÓVIL MOBILE	NOTA NOTE
			DESDE SINCE	HASTA TO	FIJO FIXED	EM euromotor®			

Todo terreno

HYUNDAI GALLOPER

3.0V6	2972	N	G6AT	1998				12227	
3.0V6	2972	N		1998		12306		12324	
2.5 TDI	2476	D	D4BH - 4D56T	1998				1061 1184	

HYUNDAI SANTA FE

2.0 CRDi	1991	D	D4EA	08/01		12515		12513	
----------	------	---	------	-------	--	-------	--	-------	--

HYUNDAI TERRACAN

2.9 CRDi 16v	2900	D	D48HJ3	10/01				12520 12519 12518	
--------------	------	---	--------	-------	--	--	--	-------------------------	--

HYUNDAI TUCSON

2.0 CRDi 16v	1991		D4EA	03/01		12515		12513	
--------------	------	--	------	-------	--	-------	--	-------	--

CÓDIGO CODE	EM	CÓDIGO ORIGINAL ORIGINAL CODE	CÓDIGO CODE	EM	CÓDIGO ORIGINAL ORIGINAL CODE	CÓDIGO CODE	EM	CÓDIGO ORIGINAL ORIGINAL CODE
1061		23417-42000=23417-42010=23417-42020	1184		23357-42000=23357-42010=23357-42020	12227		24410-35010=24410-35020
12306		MD121447=MD319022	12324		MD140071	12513		24410-27000
12515		244140-27000 REP	12518		55112730A=88R12730	12519		88R12750
12520		88R12740						

EM euromotor®

VERSION PDF 2010



$\varnothing 18$



INNOCENTI

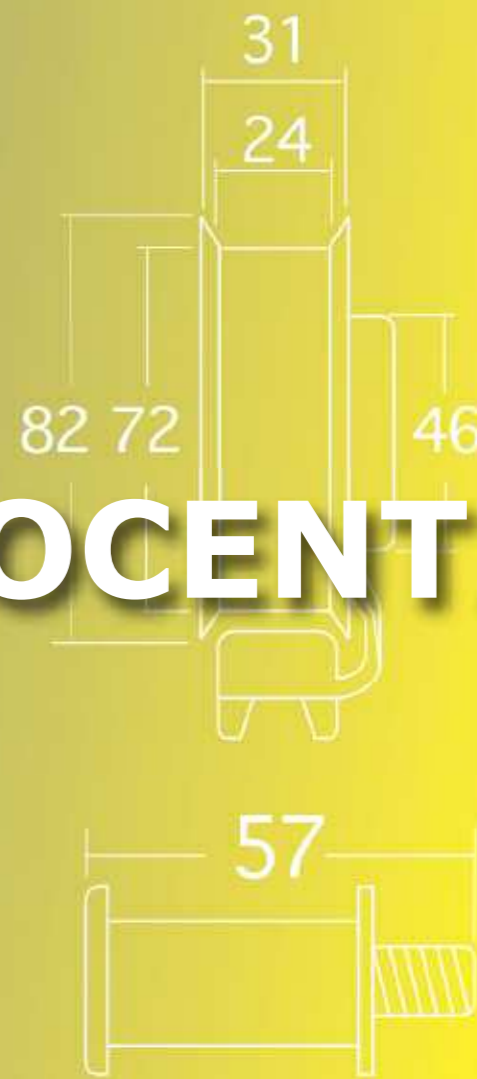

MODELO MODEL	COMB. / FUEL	MOTOR ENGINE	AÑO YEAR		CÓDIGO CODE		
			DESDE SINCE	HASTA TO	FIJO FIXED	MÓVIL MOBILE	NOTA NOTE

INNOCENTI ELBA

1.3	1297	N	146A/C/D50005000		1996	1822	
1.5	1499	N	149C1000		1996		1818
1.6	1581	N	146C/D6000		1996	1822	
1.7 D	1697	D	146B2000		1996	1820	1819

INNOCENTI MILLE - MILLECLIP

1.0	994	N	146C7000	1994		1822	
1.4	1372	N	160A1046	1994		1822	
1.7 D	1697	D	149B2000	1994		1820	1819

INNOCENTI MINI

3 cilindros	846	N	Daihatsu	1986			12495
-------------	-----	---	----------	------	--	--	-------

CÓDIGO CODE	EM	CÓDIGO ORIGINAL ORIGINAL CODE	CÓDIGO CODE	EM	CÓDIGO ORIGINAL ORIGINAL CODE	CÓDIGO CODE	EM	CÓDIGO ORIGINAL ORIGINAL CODE
1818		5997325	1819		7553564	1820		7553565
1822		5972277	12495		13505-87203			

EM euromotor®

VERSION PDF 2010



Ø18

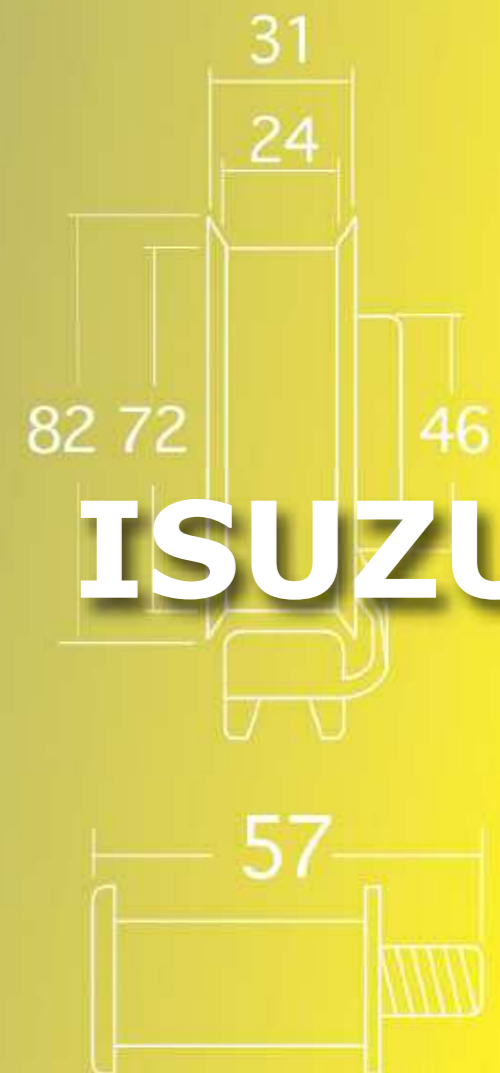

ISUZU



EM euromotor[®]

VERSION PDF 2010



Ø18

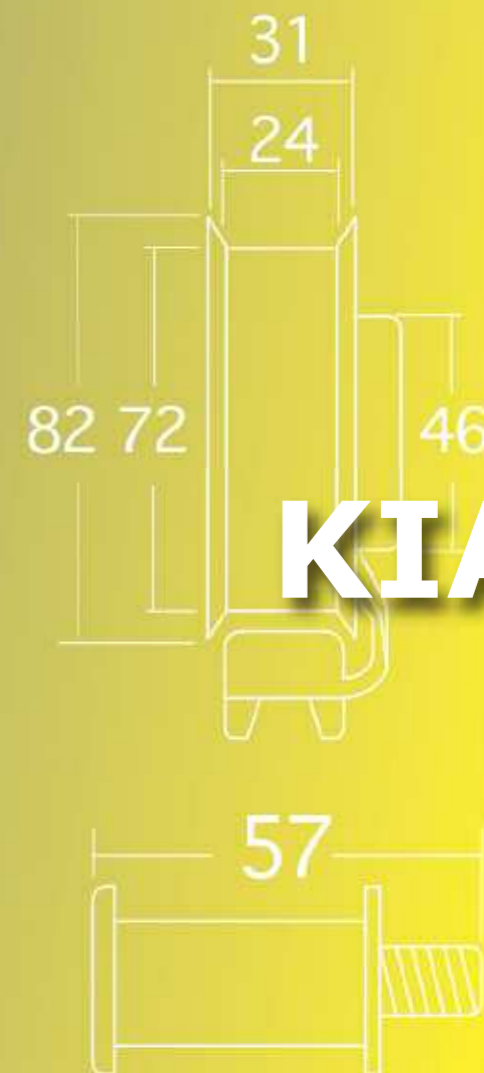

KIA



MODELO MODEL	COMB./FUEL	MOTOR ENGINE	AÑO YEAR		CÓDIGO CODE EM euromotor®		
			DESDE SINCE	HASTA TO	FIJO FIXED	MÓVIL MOBILE	NOTA NOTE

KIA AVELLA

1.3 16v	1343	N	B3 (SOHC)	03/94			12410 12410
---------	------	---	-----------	-------	--	--	----------------

KIA CAPITAL

1.5	1498	N	B5 (SOHC)	1990	1994		12410 12410
1.5 16v	1498	N	B5 (SOHC)	1990	1994	12235	12222
1.8	1793	N	F8	1990	1994		12220

KIA CARENS II

1.8 16v	1793	N		07/02			12235 12517
2.0 CRDI	1991	D	D4	08/02		12515	12513

KIA CARNIVAL

2.9 DTI 16v				09/98	05/00	12518 12519 12520	12220
2.9 CRDI 16v	2898	D	UP	06/00		12518 12519 12520	

KIA CLARUS

1.8 16v	1793	N	T8	07/96			12235 12517
2.0 16v	1998	N	FE	07/96		1075	12221

KIA JOICE

	1997	N		02/00		1075	12223
--	------	---	--	-------	--	------	-------

KIA PICANTO

1.1 12v		N	G4HG				12277
---------	--	---	------	--	--	--	-------

KIA POTENTIA

2.0	1998	N	FE20 (DOHC)	11/93	05/95	1075	12223 12221
2.2	2200	N	FE22 (DOHC)	11/93	05/95	1075	12223 12221

CÓDIGO CODE EM	CÓDIGO ORIGINAL ORIGINAL CODE
-------------------	----------------------------------

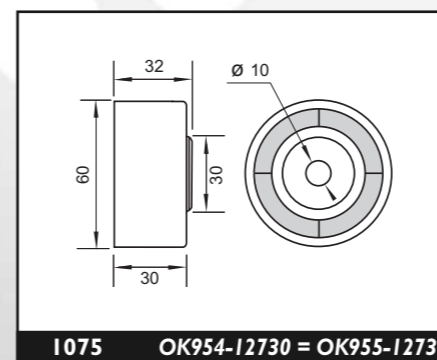

CÓDIGO CODE EM	CÓDIGO ORIGINAL ORIGINAL CODE
-------------------	----------------------------------

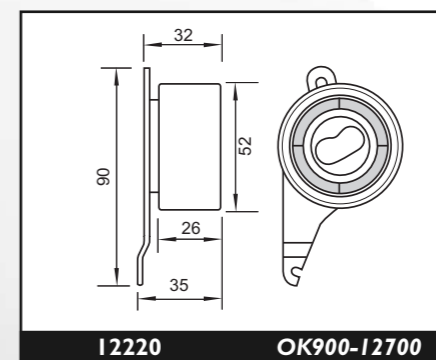

CÓDIGO CODE EM	CÓDIGO ORIGINAL ORIGINAL CODE
-------------------	----------------------------------

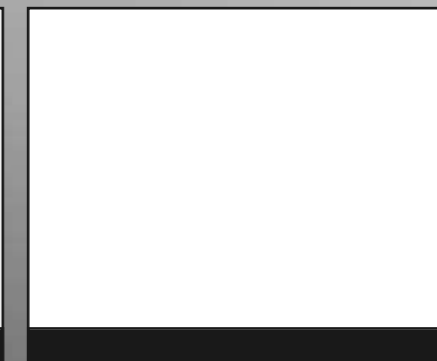
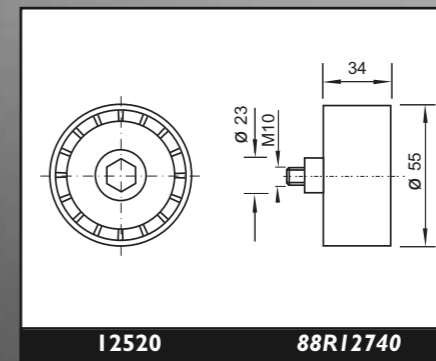
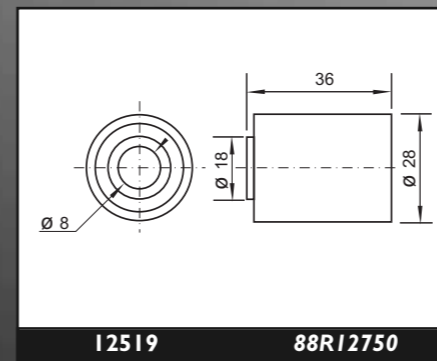
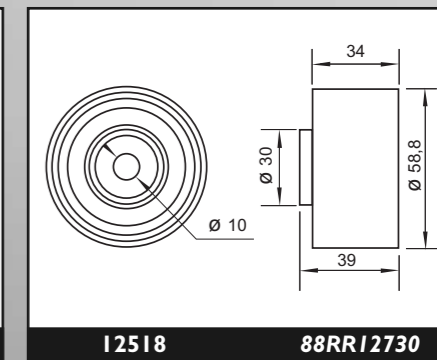
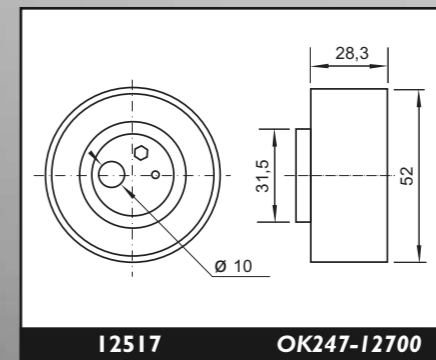
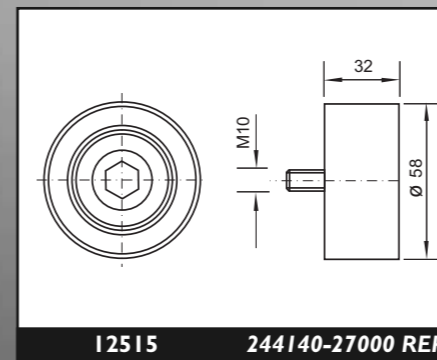
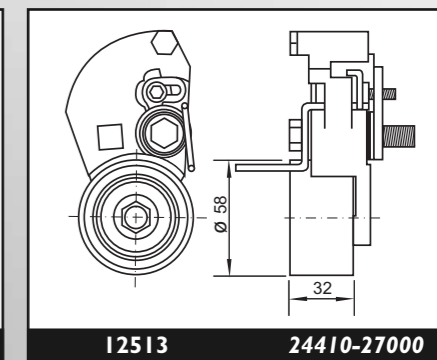
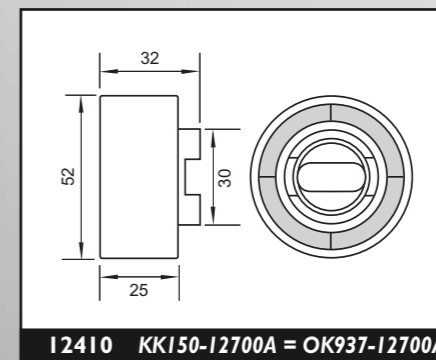
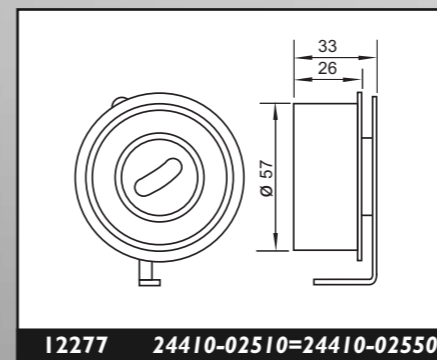
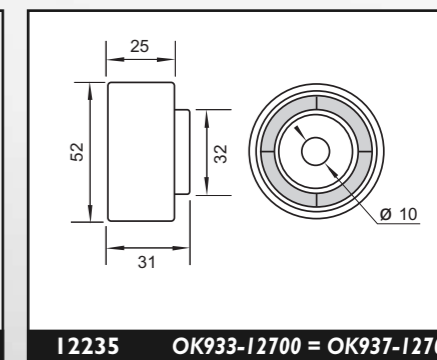
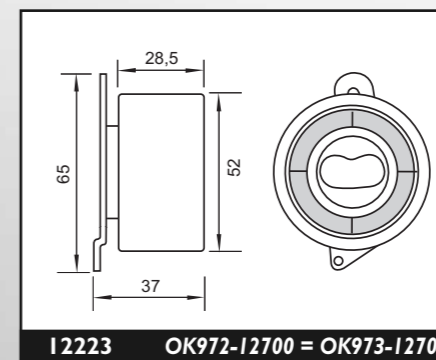
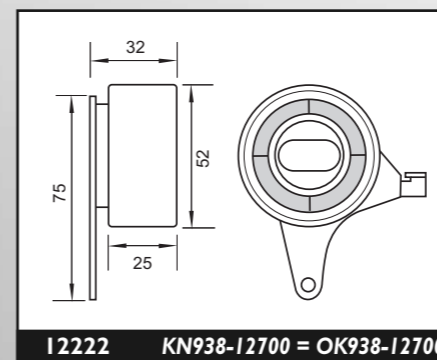
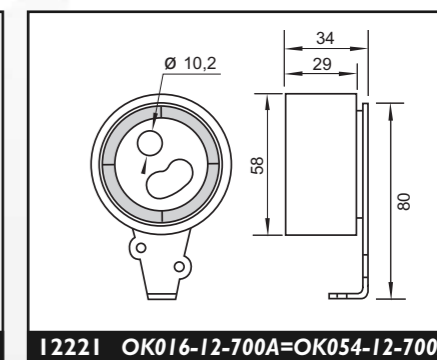

MODELO MODEL	COMB./FUEL	MOTOR ENGINE	AÑO YEAR		CÓDIGO CODE		
			DESDE SINCE	HASTA TO	FIJO FIXED	MÓVIL MOBILE	NOTA NOTE

KIA PRIDE

I.1	I138	N	B1	01/91			I2410	
I.3	I324	N	B3	01/90			I2410	

KIA RIO

I.3	I324	N	B3	08/00			I2410	
I.5 16v	I493	N		10/97		I2235	I2222	
I.5 16v	I498	N		08/00			I927	

KIA SEPHIA

I.5	I498	N	B5 (DOHC)	09/92	09/97		I2410	
I.5 16v	I498	N	B5 (DOHC)	09/92	09/97	I2235	I2410	
I.6	I598	N	B6	09/92	09/97	I2235	I2410	
I.6 16v	I598	N	B6	09/92	09/97	I2235	I2222	

KIA SHUMA

I.5 16v	I498	N		10/97		I2235	I2222	
---------	------	---	--	-------	--	-------	-------	--

KIA SPORTAGE

2.0	1998	N	FE	04/94		I075	I2223	
2.0 16v	1998	N	FE (DOHC)	04/94		I075	I2223	
2.2 D	2200	D	HW	05/93			I2221 I2221	

CÓDIGO CODE	EM	CÓDIGO ORIGINAL ORIGINAL CODE
I075		OK954-12730 = OK955-12730

CÓDIGO CODE	EM	CÓDIGO ORIGINAL ORIGINAL CODE
I927		I4510-PM7-004

CÓDIGO CODE	EM	CÓDIGO ORIGINAL ORIGINAL CODE
I2221		OK016-12-700A=OK054-12-700A

CÓDIGO CODE	EM	CÓDIGO ORIGINAL ORIGINAL CODE
I2222		KN938-12700 = OK938-12700

CÓDIGO CODE	EM	CÓDIGO ORIGINAL ORIGINAL CODE
I2223		OK972-12700 = OK973-12700

CÓDIGO CODE	EM	CÓDIGO ORIGINAL ORIGINAL CODE
I2235		OK933-12700 = OK937-12700

CÓDIGO CODE	EM	CÓDIGO ORIGINAL ORIGINAL CODE
I2410		KK150-12700A = OK937-12700A

CÓDIGO CODE	EM	CÓDIGO ORIGINAL ORIGINAL CODE

CÓDIGO CODE	EM	CÓDIGO ORIGINAL ORIGINAL CODE

CÓDIGO CODE	EM	CÓDIGO ORIGINAL ORIGINAL CODE

CÓDIGO CODE	EM	CÓDIGO ORIGINAL ORIGINAL CODE

CÓDIGO CODE	EM	CÓDIGO ORIGINAL ORIGINAL CODE

CÓDIGO CODE	EM	CÓDIGO ORIGINAL ORIGINAL CODE

CÓDIGO CODE	EM	CÓDIGO ORIGINAL ORIGINAL CODE

CÓDIGO CODE	EM	CÓDIGO ORIGINAL ORIGINAL CODE

EM euromotor®

VERSION PDF 2010

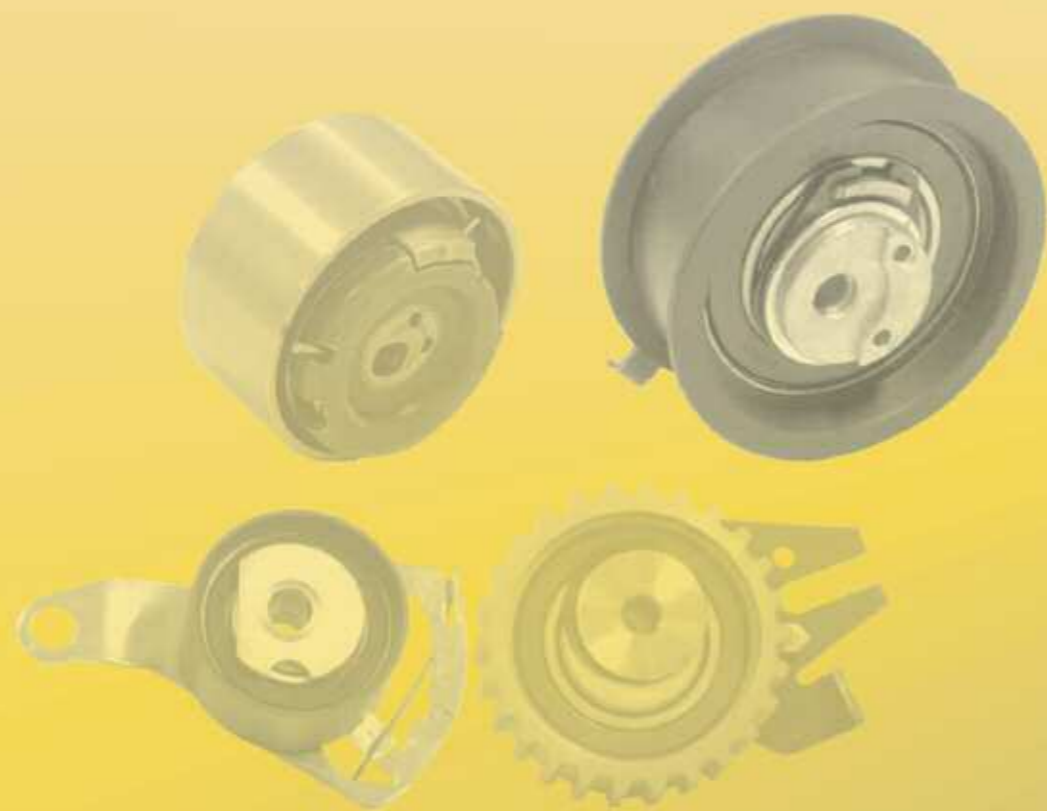

Ø18

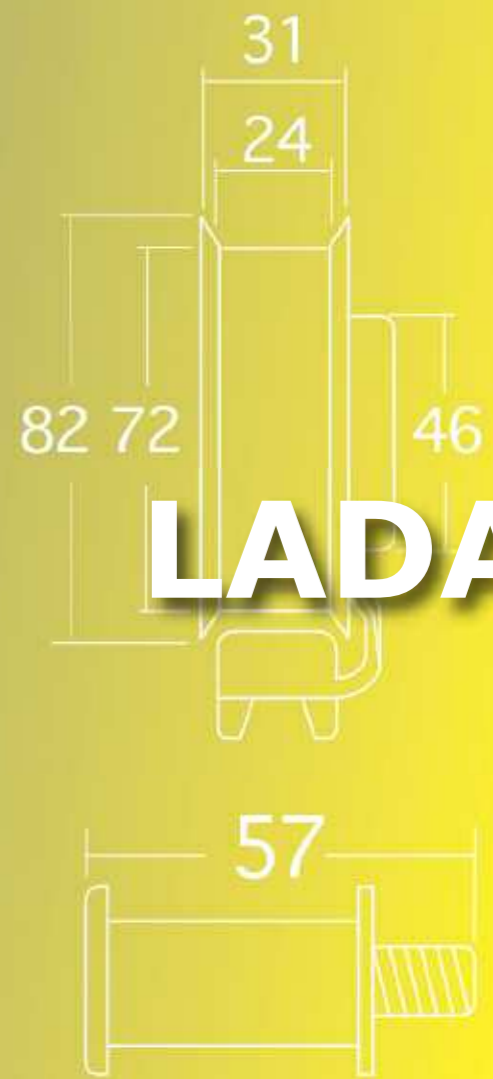

LADA



MODELO MODEL	MOTOR ENGINE	AÑO YEAR		CÓDIGO CODE		
		DESDE SINCE	HASTA TO	FIJO FIXED	MÓVIL MOBILE	NOTA NOTE

LADA

110	N	C20XE	1996		1906 1907	1100	
1300	N	BA32108	1992	1994	12190		

LADA NIVA

1.9 D	1905	D	XUD9	1987	12/93	1814	1813
1.9 D	1905	D	XUD9	01/94		1900	1901
1.9 TD	1905	D	XUD9	1987	12/93	1814	1813
1.9 TD	1905	D	XUD9	01/94		1900	1901

LADA NOVA

1.2	N	BA32101-2105	01/80		12190		
1.3	N	BA32101-2105	01/80		12190		
1.5	N	BA32101-2105	01/80		12190		

LADA SAGONA

1.5	N	BA321083	01/92	12/94	12190		
-----	---	----------	-------	-------	-------	--	--

LADA SAMARA

1.1	N	BA321081-83	01/80	12/94	12190		
1.3	N	BA321081-83	01/80	12/94	12190		
1.5	N	BA321081-83	01/80	12/94	12190		
1.5	N	BA32111	01/95		12190	12191	

CÓDIGO CODE	EM	CÓDIGO ORIGINAL ORIGINAL CODE	CÓDIGO CODE	EM	CÓDIGO ORIGINAL ORIGINAL CODE	CÓDIGO CODE	EM	CÓDIGO ORIGINAL ORIGINAL CODE
1100	90158004 = 90530125		1813	0829.11=0829.21		1814	0830.02=0830.15	
1900	9615923380		1901	9617188680		1906	90530126	
1907	636416		12190	2105-1006124		12191	2108-1006120	

EM euromotor[®]

VERSION PDF 2010



Ø18



LANCIA



MODELO MODEL	MOTOR ENGINE	AÑO YEAR		CÓDIGO CODE		
		DESDE SINCE	HASTA TO	FIJO FIXED	MÓVIL MOBILE	NOTA NOTE

LANCIA BETA

Montecarlo-2.0	1995	N	I34AS000	07/80	05/84	1852	
----------------	------	---	----------	-------	-------	------	--

LANCIA DEDRA

1.6 8v	1581	N	I59B8000-835A1000 835A1046-835C1000	08/89	07/99	1822	
1.6 16v	1581	N	I82A4000	01/96	07/99	1951	I2091
1.8 8v	1756	N	836A5000-835A2000 835A2046-835C5000	09/89	07/99		1832
1.8 16v	1747	N	I82A2000-I83A1000	03/96	07/99	I2204	I2090
2.0	1995	N	835A5000-835A5046	09/89	08/99		1832
2.0 TB 8v	1995	N	835A7000-835A7046 835A8000-835A8046	05/90	07/99		1832
2.0 16v	1995	N	836A3000	07/94	07/99		1818
1.9 TD	1930	D	I60D1000-835A4000	04/89	07/99	1889	1835

LANCIA DELTA

1.3		N			12/85	1855	
1.3		N		11/85	1986	1872	
Delta 1.3		N	831B000/1000/8000	1986	1992		1832
Delta 1.4	1372	N	I60A1046-836A4000	10/94	2000	1822	
Delta 1.5		N			1986	1872	
Delta 1.5		N	831B000/1000/8000	1986	1992		1818
Delta 1.6		N			1986	1872	
Delta 1.6	1585	N	I49C2000	1986	1992		1823
Delta 1.6 8v	1581	N	835C1000	06/93	2000	1822	
Delta 1.6 16v	1581	N	I82A4000-I82A6000	01/96	2000	1951	I2091 (90cv - 103cv)
Delta 1.6 Turbo	1585	N	831B3000/7000/7046	1986	05/93		1823
Delta 1.8 8v	1756	N	835C2000-835C4000 835A5000/6000/4000	06/93	2000		1832
Delta 1.8 16v	1747	N	I82A2000-I83A1000	03/96	2000	I2204	I2090 (115 cv-132cv)
Delta 2.0 16v	1995	N	I86A3000	06/93	2000		1818

CÓDIGO CODE	EM	CÓDIGO ORIGINAL ORIGINAL CODE	CÓDIGO CODE	EM	CÓDIGO ORIGINAL ORIGINAL CODE	CÓDIGO CODE	EM	CÓDIGO ORIGINAL ORIGINAL CODE
1818		5997325	1822		5972277	1823		5956109
1832		7541718	1835		7596728 = F0759628	1852		4443446
1855		4385583	1872		4386575	1889		5970621 = 7596727 = 7596876 = 60808692
1951		46400054=46554826	12090		55192323 = 60813592	12091		46416489
12393		60664403 = 60671573						

MODELO MODEL	MOTOR ENGINE	AÑO YEAR		CÓDIGO CODE		
		DESDE SINCE	HASTA TO	FIJO FIXED	MÓVIL MOBILE	NOTA NOTE

LANCIA DELTA

Delta 2.0 16v Turbo	1995	N	175A4000-186A2000	06/93	2000		1818	
Delta 4WD 2.0 8v TB	1995	N	831B5000-831C5000	11/86	12/92		1832	
Delta 4WD 2.0 16v TB	1995	N	831B5000	03/89	01/94		1818	
Delta 1.9 TD	1930	D	160D1000-835A4000	10/94	2000	1889	1835	

LANCIA KAPPA

Kappa 2.0 16v Turbo	1995	N	838A4000	02/95			1818	4Cil.
2.0 20v	1998	N	838A1000-838A6000	10/94		1950	1113	5 Cil.
2.0 20v Turbo	1998	N	175A3000	06/98		1950	1113	5 Cil.
2.4 20v	2446	N	838A2000-838A2027	08/94		1950	1113	5 Cil.
3.0 V6 24v	2959	N	838B000	08/94		12152 12152	12468	
2.4 TD	2387	D	838A3000	08/94	05/98	1950	1115	(124 cv)
2.4 JTD	2387	D	838A7000-838A8000	06/98		1950	1115	(136 cv)

LANCIA LYBRA

1.6 16v	1581	N	182A4000	07/99		1951	12091	
1.8 16v	1747	N	839A4000	07/99		12393	12354	
2.0 20v	1998	N	182B7000	07/99		12467	1113	
1.9 JTD	1910	D	AR32302	07/99		1950	1115	
2.4 JTD	2387	D	839A5000-AR32501	07/99	03/03	1950	1115	
2.4 JTD	2387	D	841C000	04/03		12467	1113	

LANCIA MUSA

1.4 16v	1400	N		09/04			12155	
1.9 MJ	1910	D		09/04		12467	1113	

CÓDIGO EM CÓDIGO ORIGINAL ORIGINAL CODE

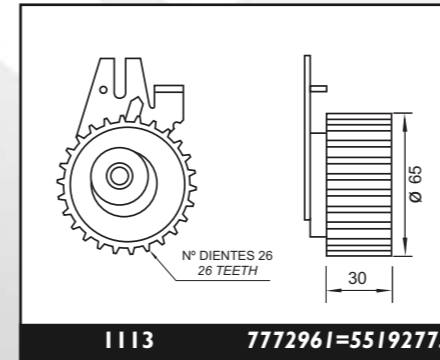

CÓDIGO EM CÓDIGO ORIGINAL ORIGINAL CODE

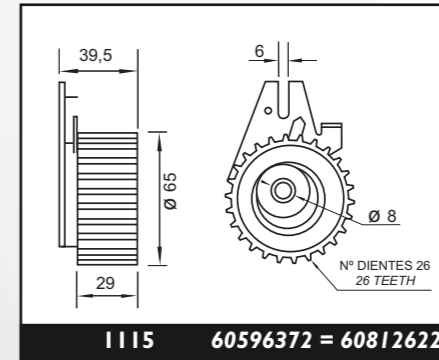

CÓDIGO EM CÓDIGO ORIGINAL ORIGINAL CODE

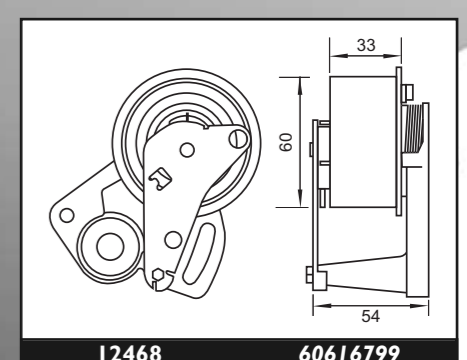
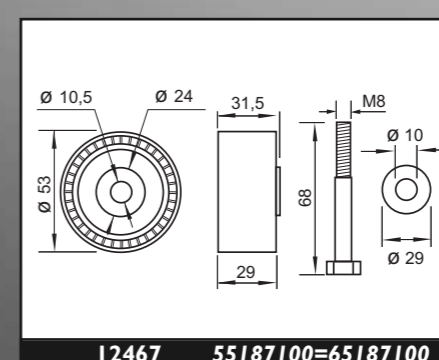
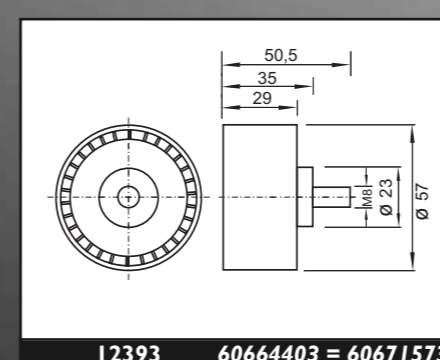
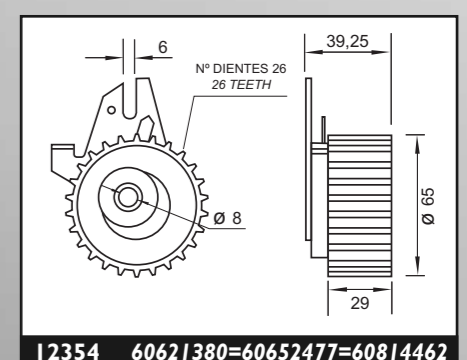
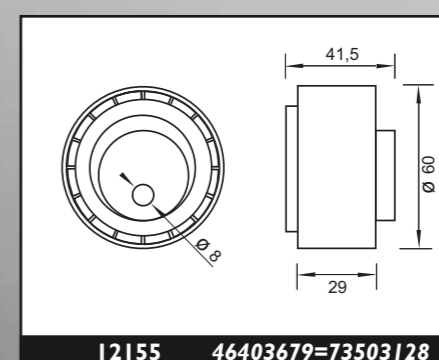
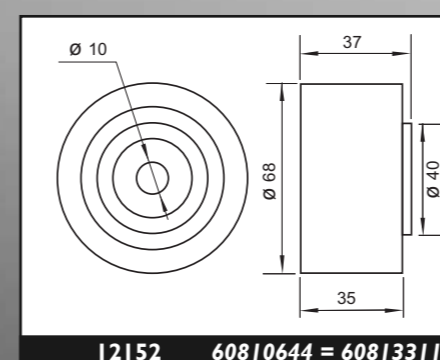
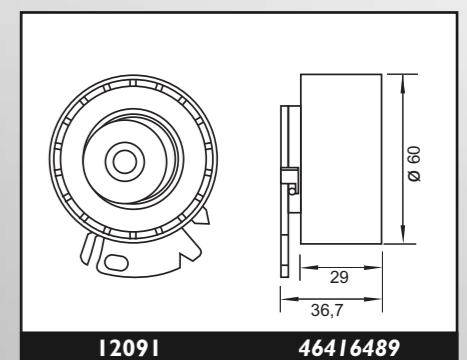
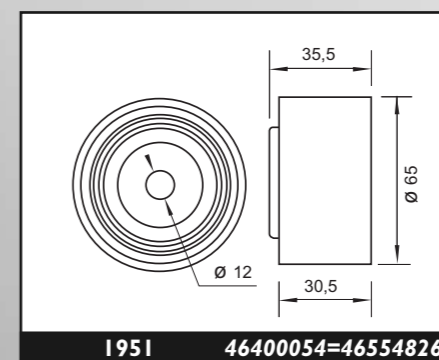
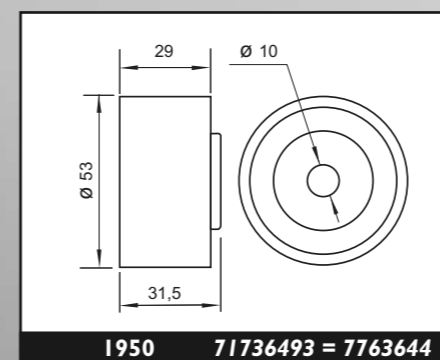
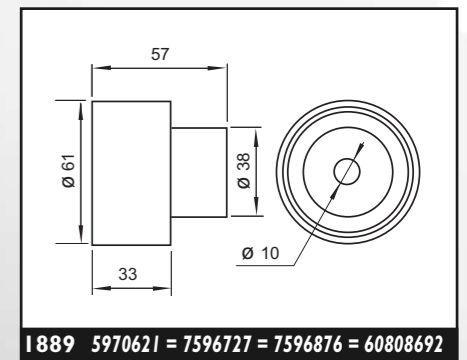
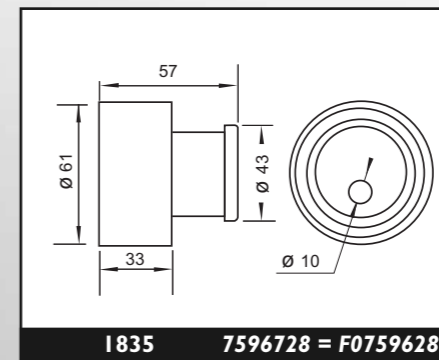
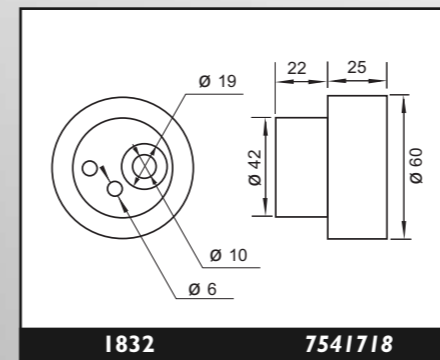
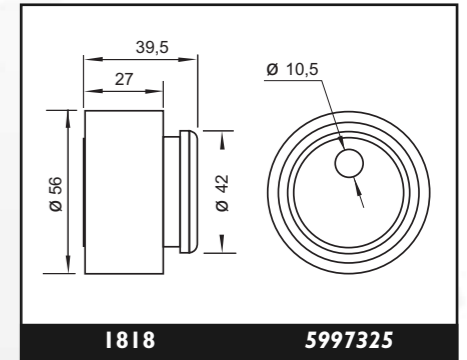

MODELO MODEL	AÑO YEAR	MOTOR ENGINE	CÓDIGO CODE			NOTA NOTE
			DESDE SINCE	HASTA TO	EM euromotor®	

LANCIA PHEDRA

2.0 16v	1997	N	RFN	08/02		92102	12334	
3.0 V6 24v	2946	N	ES9J4S	09/02		1170 1170 1171	12465	
2.0 JTD	1997	D	RHS	09/02		12094	12093	
2.4 JTD	2179	D	4HX	10/02		12094	12093	

LANCIA PRISMA

1.3	1301	N		01/83	12/86		1818	
1.3	1301	N		01/83	12/86	1872		
1.5	1498	N	I38C2048	01/83	12/86		1818	
1.5	1498	N	I38C2048	01/83	12/86	1872		
1.6	1585	N	831A4000	01/82	04/86	1872		
1.6	1585	N	I49C2000	12/82	04/86	12500		Hasta motor Up to engine 488950
1.6	1585	N	381B7000	1987	1989		1823	
2.0 8v	1995	N	831B4000	1986	1989		1832	

LANCIA THEMA

2.0 8v	1995	N	834B146-834B1000	11/84	1994		1832	
2.0 8v Turbo	1995	N	834C146	11/84	05/90		1832	
2.0 16v	1995	N	834B2000-834B2246 834F1000	05/88	12/93		1818	
2.0 16v Turbo	1995	N	834C1000-834C1246 834F2000	12/88	07/94		1818	
3.0 V6	2959	N	834F000	08/92	07/94	12153		

LANCIA THESIS

2.0 T	1998	N	841E000	04/02		1950	1113	5Cil.
2.4 20v	2446	N	841E000	04/02		1950	1113	5Cil.

CÓDIGO CODE	EM	CÓDIGO ORIGINAL ORIGINAL CODE	CÓDIGO CODE	EM	CÓDIGO ORIGINAL ORIGINAL CODE	CÓDIGO CODE	EM	CÓDIGO ORIGINAL ORIGINAL CODE
1113		7772961=55192773	1170		9616660580	1171		9616660780
1818		5997325	1823		5956109	1832		7541718
1872		4386575	1950		71736493 = 7763644	12093		9400829629
12094		9400830319=9400830289	12153		60580235	12334		9643329681
12465		9642184080	12500		4443703	92102		9632722180

MODELO MODEL	COMB./ FUEL	MOTOR ENGINE	AÑO YEAR		CÓDIGO CODE			NOTA NOTE
			DESDE SINCE	HASTA TO	FIJO FIXED	MÓVIL MOBILE	EM euromotor®	

LANCIA THESIS

3.0V6	2959	N	841A000	04/02		12152 12153	12468	
3.2V6 24v	3179	N	841A000	04/02		12152 12153	12468	
2.4JTD	2387	D	841C000	04/02		1950	1115	

LANCIA Y10

1.0	999	N	156A2000	1985	1993	1822		Motor FIRE Engine
1.1	1108	N	156A2000	1985	1993	1822		Motor FIRE Engine
1.1	1050	N		1985	1993		12027 comp.	BRASIL
1.3	1301	N	156A2000	1985	1993	1822		Motor FIRE Engine
1.3	1298	N		1985	1993		12027 comp.	BRASIL

LANCIA Y

1.1	1108	N	176B2000	04/97	12/00	1822		Motor FIRE Engine
1.2	1242	N	840A3000	03/96	02/03	1822		Motor FIRE Engine
1.2 16v	1242	N	176B9000	04/97			12155	

LANCIA YPSILON

1.2 8v		N		02/03		1822		
1.2 16v		N		02/03			12155	
1.4 16v		N		02/03			12155	

LANCIA ZETA

2.0 16v	1998	N	RFV	07/98	07/00	1862	1861	
2.0 16v	1998	N	RFN	08/00		92102	12334	
2.0 Turbo	1998	N	RGX, XUJ2CTE	05/95			1811	

CÓDIGO EM CÓDIGO ORIGINAL ORIGINAL CODE

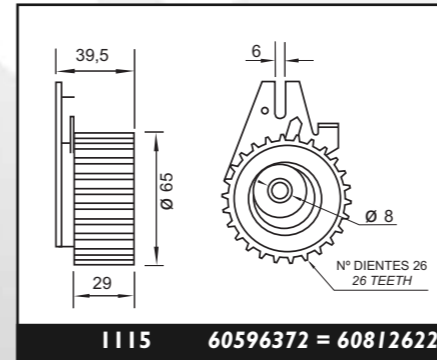

CÓDIGO EM CÓDIGO ORIGINAL ORIGINAL CODE

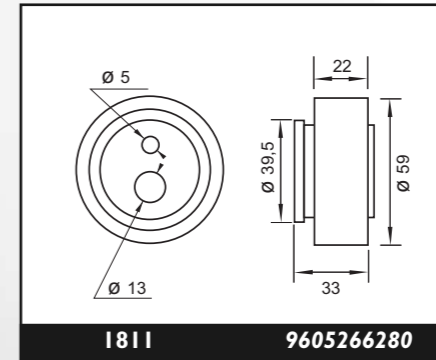

CÓDIGO EM CÓDIGO ORIGINAL ORIGINAL CODE

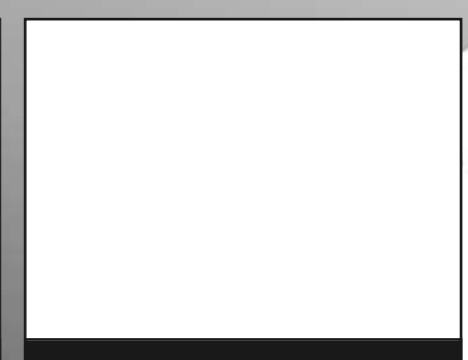
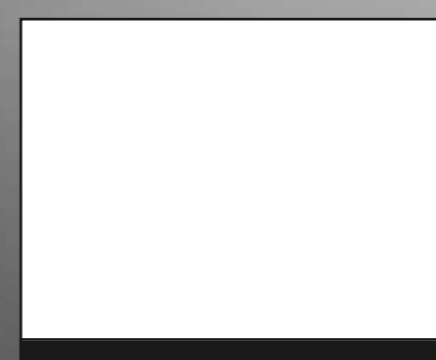
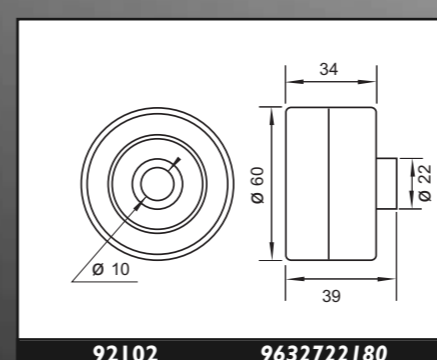
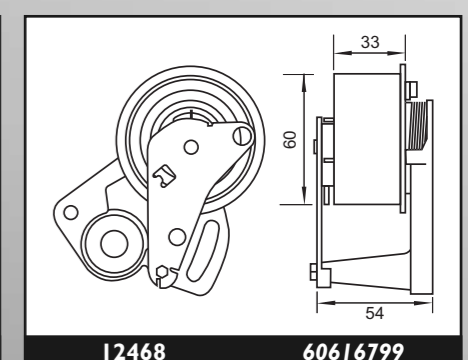
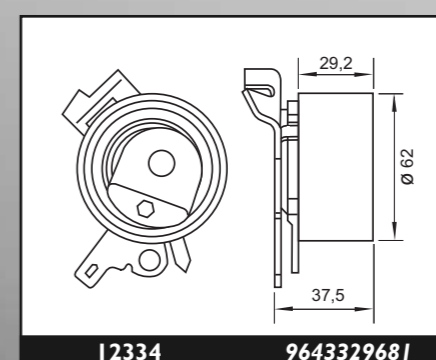
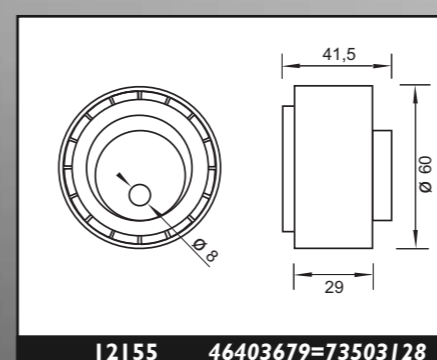
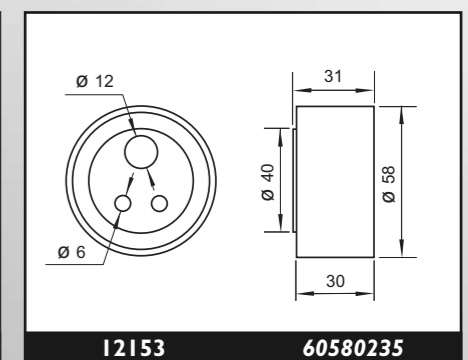
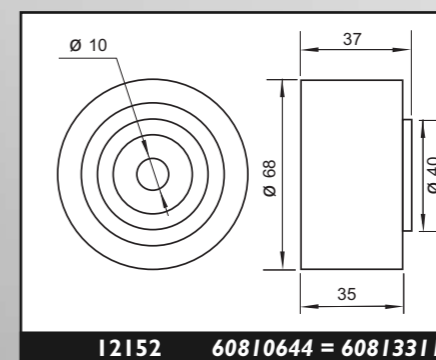
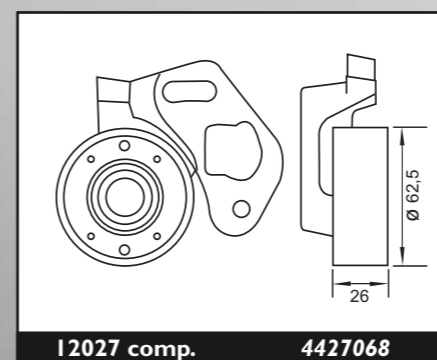
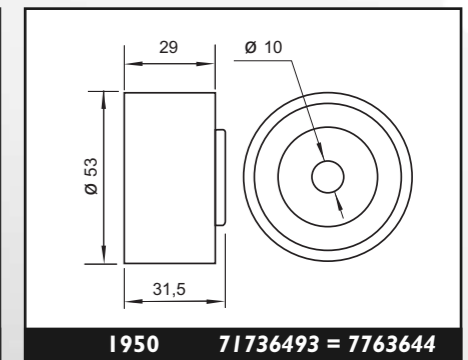
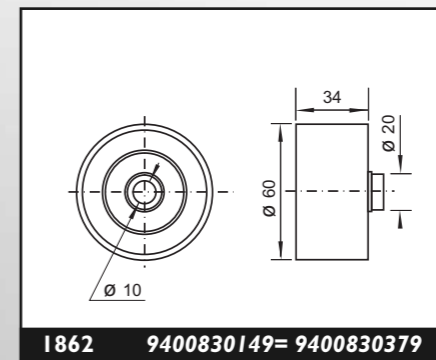
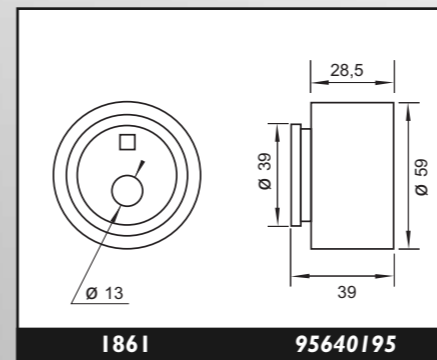
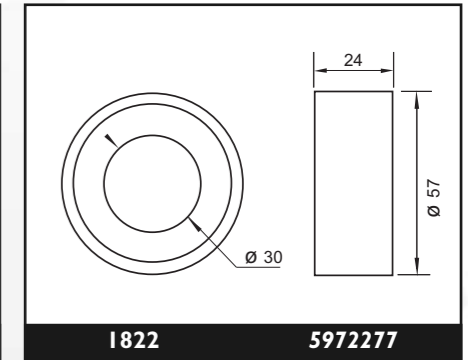

MODELO MODEL	AÑO YEAR	MOTOR ENGINE	CÓDIGO CODE		FIJO FIXED	MÓVIL MOBILE	NOTA NOTE
			DESDE SINCE	HASTA TO			

LANCIA ZETA

2.0 JTD 16v	1997	D	RHZ - RHW	10/99		12094 ó 1119	12093 ó 1118	
2.1 TD	2088	D	P8C	05/96	09/99	1862	1861	

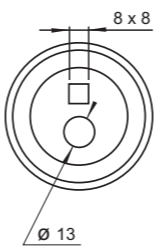
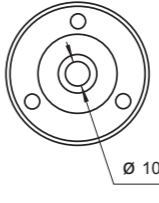
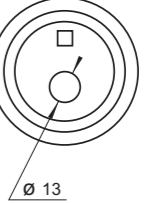
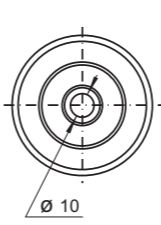
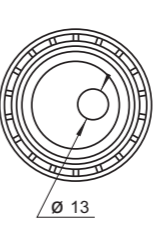
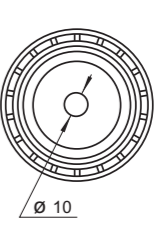
CÓDIGO CODE	EM	CÓDIGO ORIGINAL ORIGINAL CODE	CÓDIGO CODE	EM	CÓDIGO ORIGINAL ORIGINAL CODE	CÓDIGO CODE	EM	CÓDIGO ORIGINAL ORIGINAL CODE
	1118	9400829629		1119	9400830319		1861	95640195
	1862	9400830149=9400830379		12093	9400829629		12094	9400830319=9400830289

EM euromotor®

VERSION PDF 2010



Ø18



LAND-ROVER

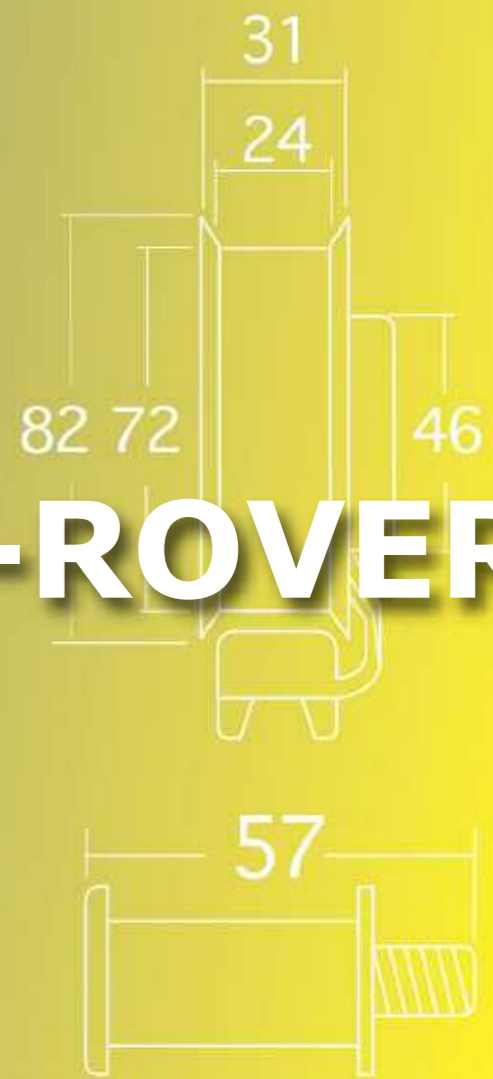

MODELO MODEL	COMB./ FUEL	MOTOR ENGINE	AÑO YEAR		CÓDIGO CODE			NOTA NOTE
			DESDE SINCE	HASTA TO	FIJO FIXED	MÓVIL MOBILE	EM euromotor®	

LAND-ROVER DEFENDER

2.5 D	2495	D	I2L - I9L	06/98		12164	12163	Hasta Up to chassis VAI17353
2.5 D	2495	D	I2L - I9L	06/98		1892	1968	Desde From chassis VAI17354
2.5 TD	2495	D	200TDi	01/86		12164	12163	
3.0 TDi	2926	D	200TDi	01/86		1892	1968	Desde From chassis VAI17354

LAND-ROVER DEFENDER 90

2.5 D	2495	D	I2L	10/95		1892		
-------	------	---	-----	-------	--	------	--	--

LAND-ROVER DEFENDER 110

2.5 TDi	2500	D	I2J	10/95		1892		
---------	------	---	-----	-------	--	------	--	--

LAND-ROVER DISCOVERY

2.0	1994	N	F20	06/93	12/98	1178	1905	
2.5 TD	2495	D		01/99		12164	12163	Desde From chassis VA393361
3.0 TDi	2926	D		01/99		1892	1968	Desde From chassis VA393361
3.0 TDi	2926	D		01/99		1892	1968	Desde From chassis VA393361

LAND-ROVER FREELANDER

1.8	1796	N	K18	02/98			1894	Tens. mecánico Mechanic tens.
2.0 SDi	1994	D	20T2N	02/98	11/00		12432	

LAND-ROVER RANGE ROVER

2.5 TD5	2495	D		01/99		1892	12163	
---------	------	---	--	-------	--	------	-------	--

CÓDIGO CODE	EM	CÓDIGO ORIGINAL ORIGINAL CODE	CÓDIGO CODE	EM	CÓDIGO ORIGINAL ORIGINAL CODE	CÓDIGO CODE	EM	CÓDIGO ORIGINAL ORIGINAL CODE
1178		LHP100490	1892		LHV 100150	1894		LHP 10015
1905		LHP100450	1968		LHP100680	12163		ERR1972
12164		ETC 8560	12432		LPH100390			

EM euromotor®

VERSION PDF 2010



$\varnothing 18$

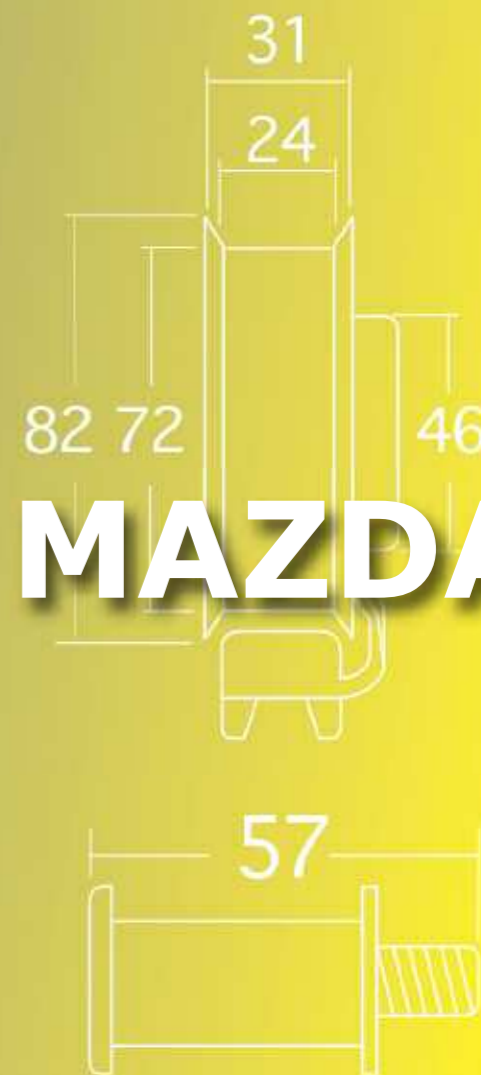

MAZDA



MODELO MODEL	COMB./FUEL	MOTOR ENGINE	AÑO YEAR		CÓDIGO CODE EM euromotor®		
			DESDE SINCE	HASTA TO	FIJO FIXED	MÓVIL MOBILE	NOTA NOTE

MAZDA 121

1.2 16v	1242	N	DHA - DHB	04/96			12297	
1.3 16v	1324	N	B3 (16v)	11/90	03/96		12410	
1.8 D	1753	D	RT	03/96	08/96	1902	1985 1915	Bomba inyectora Injection pump

MAZDA 323

1.3	1296	N	E3	09/85	12/87		12410	
1.3	1324	N	B3E - B383	09/89	03/94		12410	
1.3 16v	1324	N	B3 (16v)	09/89	07/94		12410	
1.3 16v	1324	N	B3 (16v)	08/94	09/98	12235	12410	
1.4	1324	N	B3	09/87	10/89		12410	
1.4 16v	1324	N	B3ME	10/98		12235	12410	
1.5	1490	N	B5 - E5	08/85	05/89		12410	
1.5 16v	1489	N	Z5 - DE	08/94	09/98	12235	12410	
1.5 16v	1498	N		10/98		12235	12410	
1.6	1597	N	B6	08/85	10/89		12410	
1.6	1598	N	B6E	09/89	06/91		12410	
1.6 GT Turbo	1597	N	B6 Turbo	10/85	11/91	12235	12222	
1.6 16v	1598	N	B6	03/91	10/94		12410	
1.8 16v	1840	N	BP - BP52	04/91	10/94		12410	
1.8 16v	1840	N	B5/BP (DOHC)	09/89	03/93	12235	12222	
1.8 16v	1840	N	BP - ZE	08/94	05/98	12235	12222	
1.8 16v	1840	N	BP - ZE	06/98	09/98	12523	12325	
1.8 16v	1840	N		10/98		12523	12325	
1.8 16v Turbo	1840	N		09/90	07/94	12235	12222	
1.7 D	1720	D	PN27 - PN46	04/86	05/89	1878	12196 1126	
2.0 D	1998	D	RF	10/96		12524 12524	12525	

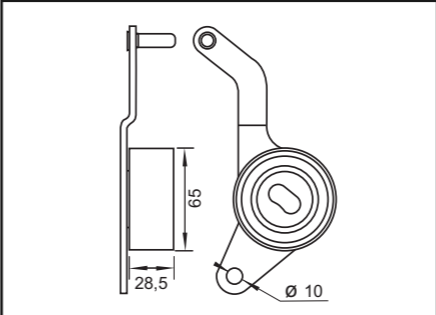
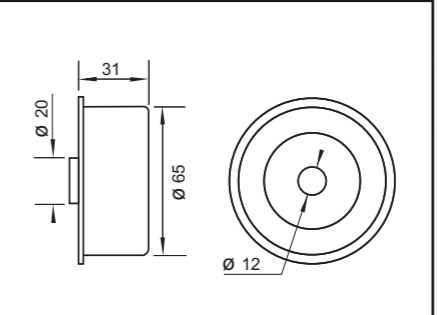
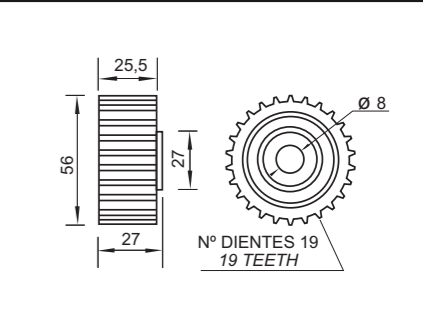
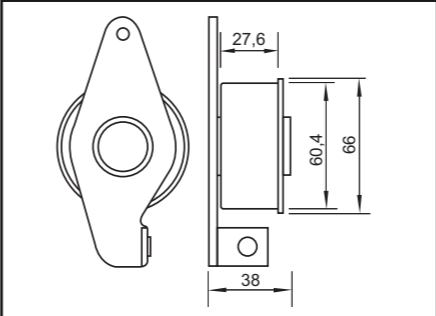
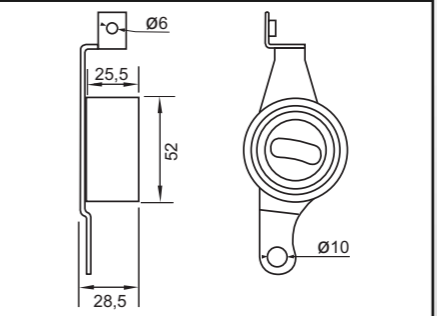
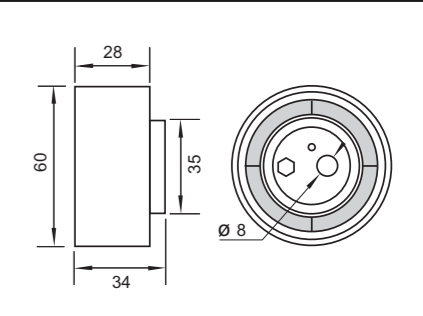
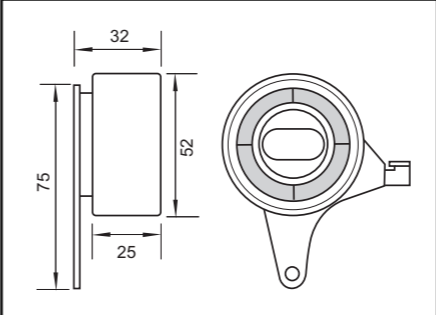
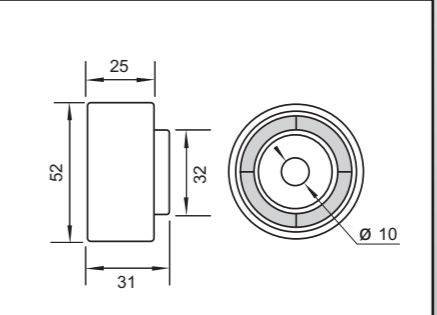
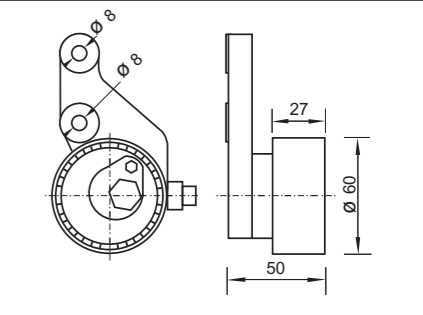
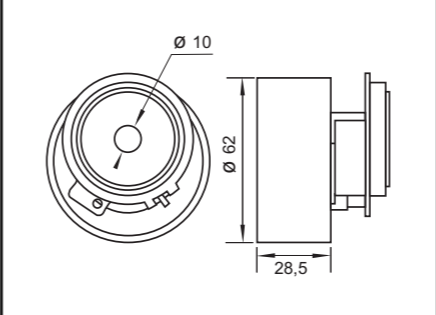
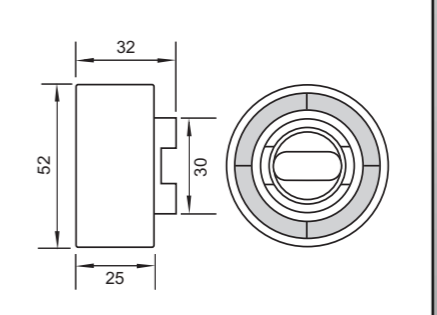
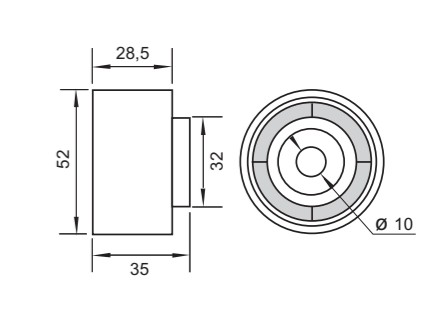
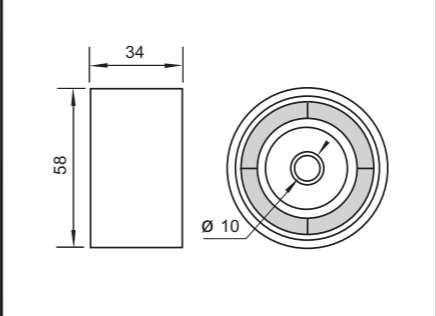
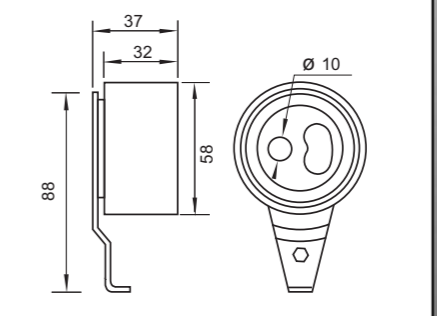
CÓDIGO CODE EM	CÓDIGO ORIGINAL ORIGINAL CODE	CÓDIGO CODE EM	CÓDIGO ORIGINAL ORIGINAL CODE	CÓDIGO CODE EM	CÓDIGO ORIGINAL ORIGINAL CODE
	1126	Y701-12700A		1878	Y701-12730
	1902	IE07-23915A = IE07-23915B		1915	IE07-02720
	1985	IE07-12700		12196	PN11-12700
	12222	B660-12700D=B660-12700E		12235	B660-12730C
	12297	IE66-12700A		12325	FP05-12700A=FP01-12700
	12410	B630-12700C=B630-12700D		12523	FS01-12730=FS01-12730A
	12524	RF71-12730A		12525	RF71-12700C=RFC6-12700

MODELO MODEL	COMB./FUEL	MOTOR ENGINE	AÑO YEAR		CÓDIGO CODE EM euromotor®		
			DESDE SINCE	HASTA TO	FIJO FIXED	MÓVIL MOBILE	NOTA NOTE

MAZDA 2

1.2 16v		N		01/03			12505
1.4 16v	1388	N		01/03			12505
1.4 DiT	1398	D	DV4TD	01/03		12377	12498

MAZDA 3

1.6 16v		N		07/03		1122	12451
1.6 CD 16v	1560	D	DV6TED4	07/03		12377	12498

MAZDA 626

1.6	1587	N	F6	03/83	09/87		12526
1.6	1587	N	F6	07/85	12/86		12220
1.8	1789	N	F8	11/87	05/92	12197 1075	12223
1.8	1798	N	FP	01/91	12/97	12523	12325
1.9	1840	N	GW	05/97		12523	12325
2.0	1998	N	FE	03/83	09/87		12220
2.0	1998	N	FE - FE (16v)	09/87	10/90	12197 1075	12223
2.0 12v	1984	N	FE (12v)	11/87	12/92	12197 1075	12223
2.0 16v	1998	N	FE - FE (16v)	09/87	10/90	12197 1075	12223
2.2 16v	2184	N	F2	06/88	04/92	12197 1075	12223
2.0 D	1984	D	RF46	03/84	06/87	12524	12527 12525
2.0 D	1998	D	RF OHC-RF-CX	05/92	12/97	12524	12525
2.0TD	1998	D	GF	01/98		12524	12525

MAZDA 929

2.0	1998	N	FE	03/84	09/87	12197	12526
2.0	1984	N	FE	06/87	12/88	12197	12223
2.2	2184	N	F2 - F21 - F2E	01/88	04/89	12197	12223

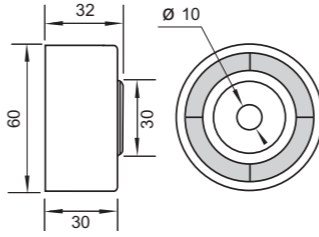
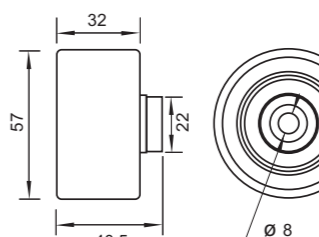
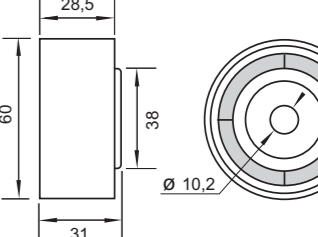
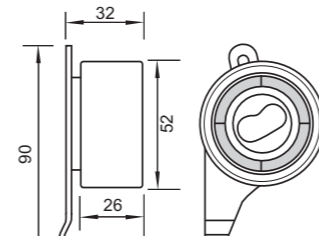
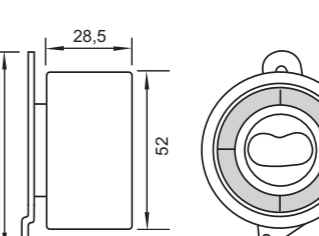
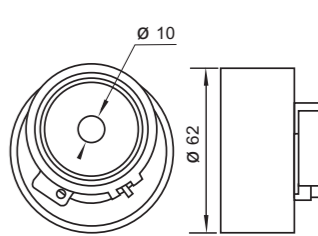
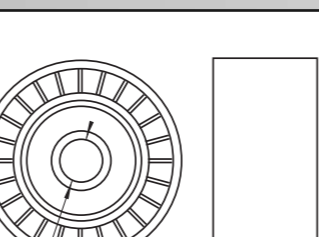
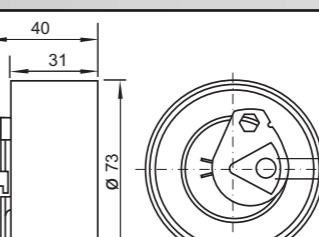
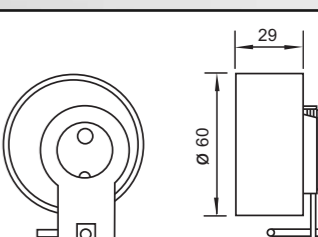
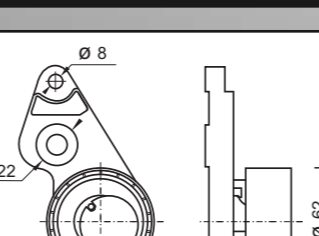
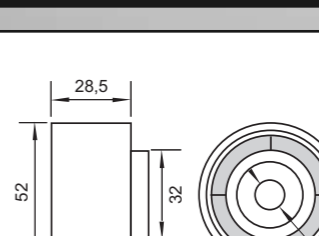
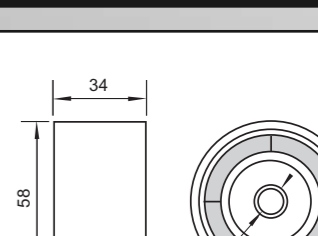
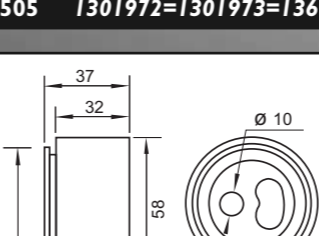
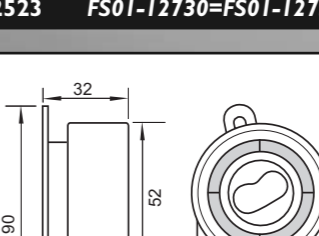
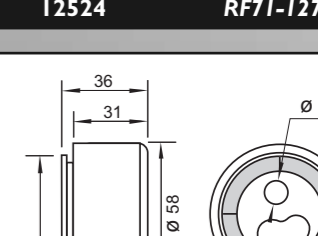
CÓDIGO CODE EM	CÓDIGO ORIGINAL ORIGINAL CODE	CÓDIGO CODE EM	CÓDIGO ORIGINAL ORIGINAL CODE	CÓDIGO CODE EM	CÓDIGO ORIGINAL ORIGINAL CODE
	FE3N-12730		0830.20		FE1H-12730A
1075		1122		12197	
	F805-12700A		FE1H-12700A		FP05-12700A=FP01-12700
12220		12223		12325	
	Y401-12730		0829.82=96374926		Y401-11270
12377		12451		12498	
	1301972=1301973=1361840		FS01-12730=FS01-12730A		RF71-12730A
12505		12523		12524	
	RF71-12700C=RFC6-12700		F801-12700=F802-12700		RF03-12700A
12525		12526		12527	

MODELO MODEL	COMB./ FUEL	MOTOR ENGINE	YEAR		CÓDIGO ORIGINAL CODE		
			DESDE SINCE	HASTA TO	FIJO FIXED	MOVIL MOBILE	NOTA NOTE

CÓDIGO ORIGINAL ORIGINAL CODE	CÓDIGO ORIGINAL ORIGINAL CODE	CÓDIGO ORIGINAL ORIGINAL CODE	CÓDIGO ORIGINAL ORIGINAL CODE
----------------------------------	----------------------------------	----------------------------------	----------------------------------

MAZDA B1600

1600	1587	N	F6	01/85	02/95		12220	
------	------	---	----	-------	-------	--	-------	--

MAZDA B2000

2000	1998	N	FE	01/85	02/95		12220	
------	------	---	----	-------	-------	--	-------	--

MAZDA B2200

2.2	2184	N	F2	1990	1995		12197 1075	12223
-----	------	---	----	------	------	--	---------------	-------

2.2 D	2169	D	R2	1990	1995			12221
-------	------	---	----	------	------	--	--	-------

MAZDA DEMIO

1.3 16v	1324	N		08/98			12235	12410
---------	------	---	--	-------	--	--	-------	-------

1.5 16v	1498	N		04/00			12235	12410
---------	------	---	--	-------	--	--	-------	-------

MAZDA E1800

1800	1789	N	F8	01/84	12/86		12220	
------	------	---	----	-------	-------	--	-------	--

1800	1789	N	F8	01/88	02/92		12197 12220	12223
------	------	---	----	-------	-------	--	----------------	-------

MAZDA E2000

2.0 SRY	1998	N	FE	01/84	12/86		12220	
---------	------	---	----	-------	-------	--	-------	--

2.0 SRY	1998	N	FE	01/88			12197	12223
---------	------	---	----	-------	--	--	-------	-------

MAZDA E2200

2.2 D	2169	D	R207	01/86	1996			12221
-------	------	---	------	-------	------	--	--	-------

MAZDA EUNOS ROADSTER

1.6	1587	N	B6	09/89	1990		12235	12222
-----	------	---	----	-------	------	--	-------	-------

MAZDA MPV

2.0i 16v	1991	N	FS - DS	09/99			12523	12325
----------	------	---	---------	-------	--	--	-------	-------

MAZDA MX3

1.6	1598	N	B6 - B6D	07/91				12410
-----	------	---	----------	-------	--	--	--	-------

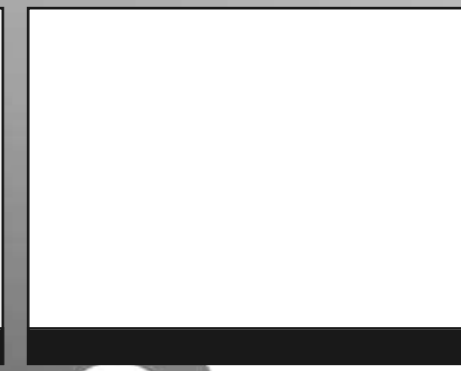
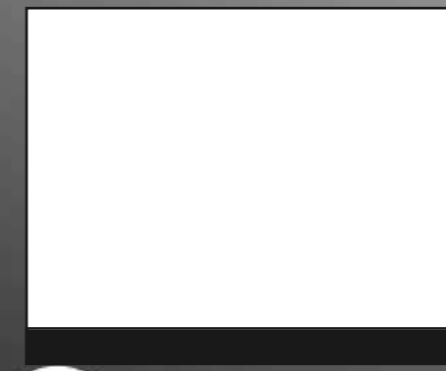
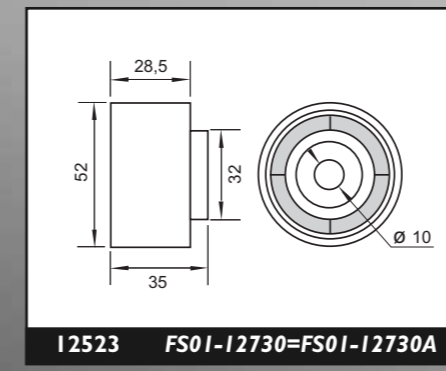
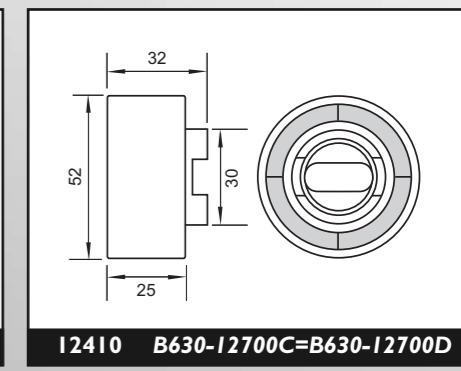
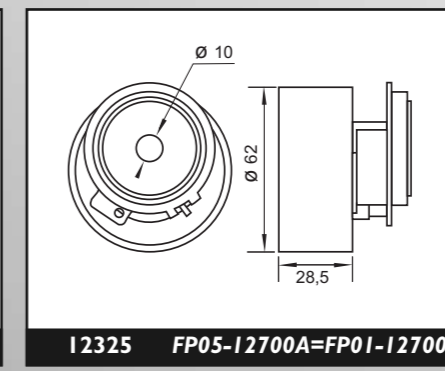
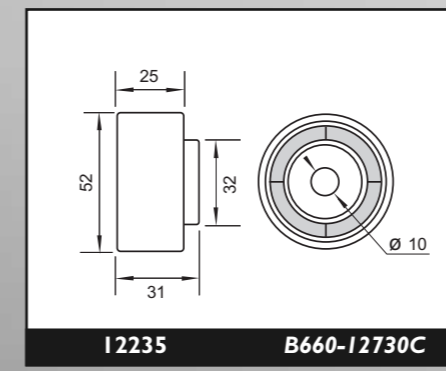
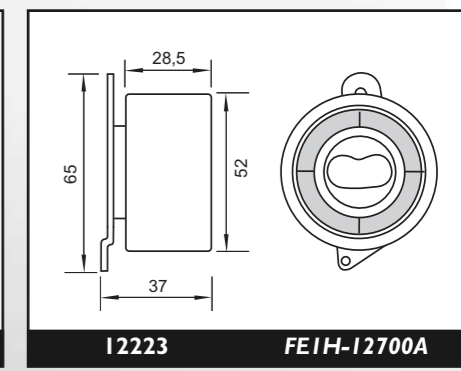
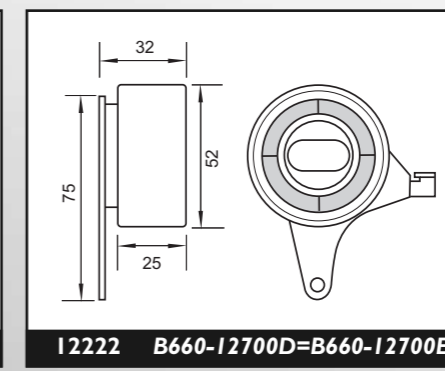
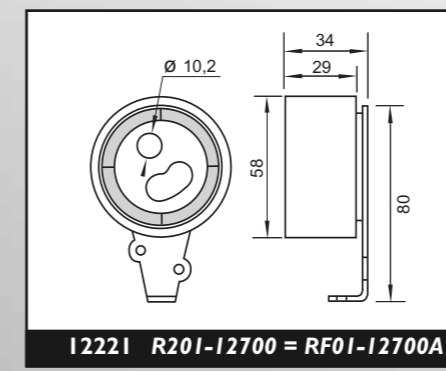
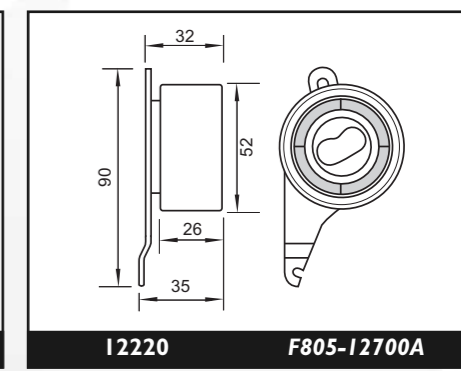
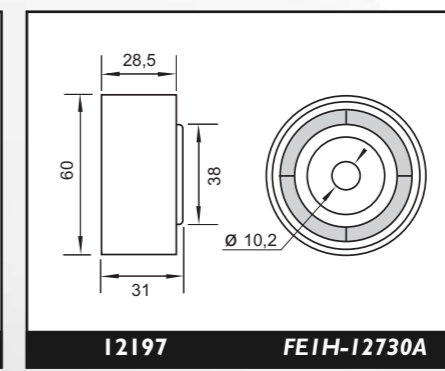
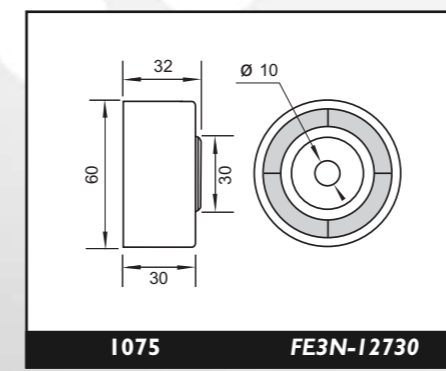

MODELO MODEL	COMB./FUEL	MOTOR ENGINE	AÑO YEAR		CÓDIGO CODE			NOTA NOTE
			DESDE SINCE	HASTA TO	FIJO FIXED	MÓVIL MOBILE	EM euromotor®	

MAZDA MX5

1.6	1598	N	B64F	06/90	04/98	12235	12222	
1.6 16v	1597			05/98		12235	12222	
1.8	1840		BPF1	02/94	04/98	12235	12222	
1.8 16v	1839			05/98		12235	12222	

MAZDA MX6

2.0	1991	N	FS	02/92		12523	12325	
2.2	2184	N	F2	02/92		12197	12223	

MAZDA PREMACY

1.8 16v	1840	N		07/99		12523	12325	
2.0	1991	N	FS	09/99		12523	12325	

MAZDA PROTEGE

1.8	1840	N	BP (DOHC)	1992		12235	12222	
-----	------	---	-----------	------	--	-------	-------	--

MAZDA TELSTAR

1.8	1840	N	F8	02/88	03/89	12197	12223	
2.0	1991	N	FS	08/91		12523	12325	

MAZDA TRIBUTE

2.0 16v	1988	N		03/00		1904 1096	1903	
---------	------	---	--	-------	--	--------------	------	--

MAZDA XEDOS 6

1.6 16v	1598	N	B6 - B69	08/92		12235	12222	
---------	------	---	----------	-------	--	-------	-------	--

CÓDIGO CODE	EM	CÓDIGO ORIGINAL ORIGINAL CODE	CÓDIGO CODE	EM	CÓDIGO ORIGINAL ORIGINAL CODE	CÓDIGO CODE	EM	CÓDIGO ORIGINAL ORIGINAL CODE
1096		6744307	1903		6635941	1904		6635942
12197		FEIH-12730A	12222		B660-12700D=B660-12700E	12223		FEIH-12700A
12235		B660-12730C	12325		FP05-12700A=FP01-12700	12523		FS01-12730=FS01-12730A

EM euromotor[®]

VERSION PDF 2010



MERCEDES BENZ

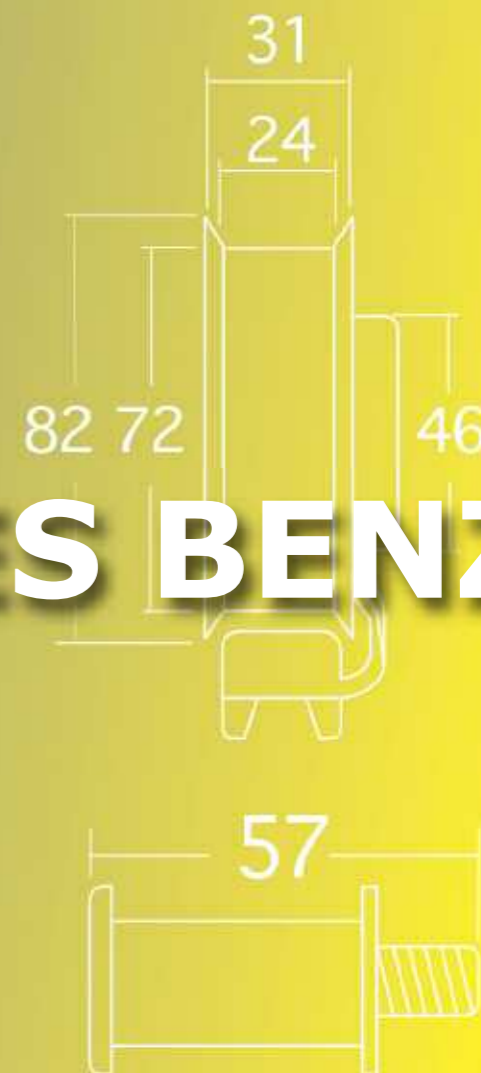

MODELO MODEL	MOTOR ENGINE	AÑO YEAR	CÓDIGO CODE EM euromotor®				
			DESDE SINCE	HASTA TO	FIJO FIXED	MÓVIL MOBILE	NOTA NOTE

MERCEDES BENZ

SPRINTER 310	2498	D	2.5 Maxion	09/97	05/01	1892	1968	Engran. cigueñal Crankshaft gear E1621
--------------	------	---	------------	-------	-------	------	------	--

CÓDIGO CODE EM	CÓDIGO ORIGINAL ORIGINAL CODE	CÓDIGO CODE EM	CÓDIGO ORIGINAL ORIGINAL CODE	CÓDIGO CODE EM	CÓDIGO ORIGINAL ORIGINAL CODE
1892	0000300169	1968	0000300069	E1621	0000520303

MERCEDES BENZ

MERCEDES BENZ

EM euromotor®

VERSION PDF 2010



Ø18

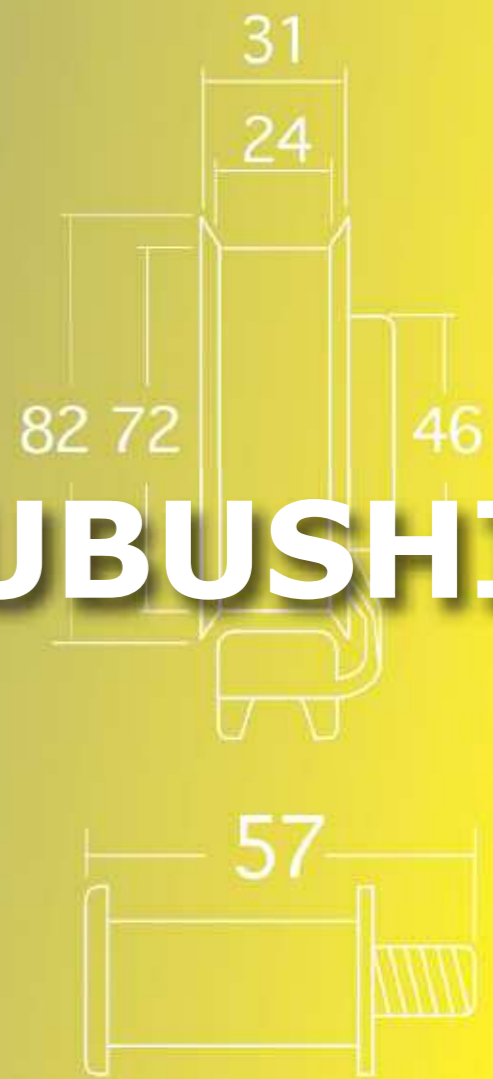

mitsubishi



MODELO MODEL	COMB./FUEL	MOTOR ENGINE	AÑO YEAR		CÓDIGO CODE			MÓVIL MOBILE	NOTA NOTE
			DESDE SINCE	HASTA TO	FIJO FIXED	EM euromotor®			

MITSUBISHI 300 GT

2972	N	6G72	1990				12227	
------	---	------	------	--	--	--	-------	--

MITSUBISHI 3000 GT

2972	N	6G72	06/92			12306	12341	
------	---	------	-------	--	--	-------	-------	--

MITSUBISHI CARISMA

1.6	1597		4G92				12323	
1.8	1834		4G93				12529	
1.8 16v	1834	N	4G93 (DOHC)	07/95		1055	12226	
1.8 GDI		N	4G93 (GDI)	09/97		1055	12226	
2.0 16v GT	1997	N		05/00		1055	12194 12528	
1.9TD	1870	D	F8Q	10/96	09/00	1854	1173	

MITSUBISHI COLT

1.3	1299	N	4G13	05/88	05/90		12400	
1.3	1299	N	4G13	06/90	04/96		12413	
1.3 12v	1299	N	4G13	06/90	04/96		12413	
1.3 12v	1299	N	4G13	05/96			12413	
1.3 12v	1299	N	4G13	05/96			12322	
1.4	1410	N	4G12	05/79	01/84		12400	
1.4 Turbo	1410	N	4G12 Turbo	05/79	01/84		12400	
1.5	1468	N	G15B - 4G15	09/84	05/90		12400	
1.5	1468	N	4G15	06/90	05/92		12413	
1.5 16v	1468	N	4G15	11/95			12400	
1.6 Turbo	1597	N	4G32T/C	02/84	12/86		12279	

CÓDIGO CODE	EM	CÓDIGO ORIGINAL ORIGINAL CODE	CÓDIGO CODE	EM	CÓDIGO ORIGINAL ORIGINAL CODE	CÓDIGO CODE	EM	CÓDIGO ORIGINAL ORIGINAL CODE
1055		MD156604	1173		MD343741=MD855993	1854		MD855992
12194		MD129355=MD182537	12226		MD169592	12227		MD104578
12279		MD008965	12306		MD319022=MD151447	12322		MD329976
12323		MD320174	12341		MD140071	12400		MD030605
12413		MD146186	12528		MD192068	12529		MD175375=MD315265

MITSUBISHI

MITSUBISHI

MODELO MODEL	COMB./FUEL	MOTOR ENGINE	AÑO YEAR		CÓDIGO CODE EM euromotor®		
			DESDE SINCE	HASTA TO	FIJO FIXED	MÓVIL MOBILE	NOTA NOTE

MITSUBISHI COLT



1.6 Turbo	1597	N	4G32T/C	01/87	04/88		12280
1.6 Gti 16v	1596	N	4G61	05/88	05/90	1055	12194
1.6	1597	N	4G92	06/92	04/96	1055	12529
1.6 16v	1597	N		05/96			12323
1.6	1600	N	G32B	01/81	03/82		12279
1.6	1600	N	G32B	04/82	12/93		12279
1.8 Gti 16v	1836	N	4G67	06/90	05/92	1055	12194 12206
1.8 Gti 16v	1834	N	4G93	06/92	04/96	1055	12226
1.8 D	1796	D	4D65	02/84	05/92	12309	12401 12530

MITSUBISHI ECLIPSE

2.0	1997	N	4G63	04/91	11/95	1055	12194 12206
2.0	1997	N	4G63	01/96		1055	12194 12528

MITSUBISHI GALANT

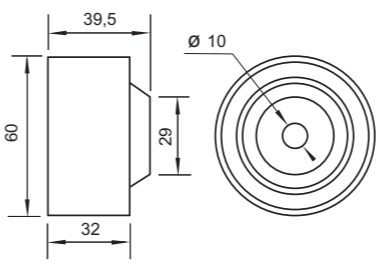
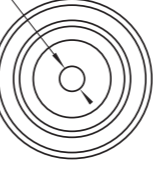
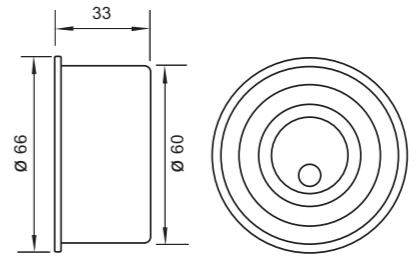
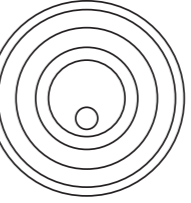
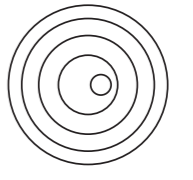
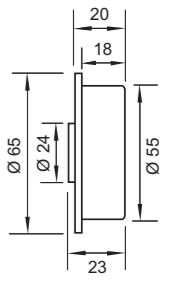
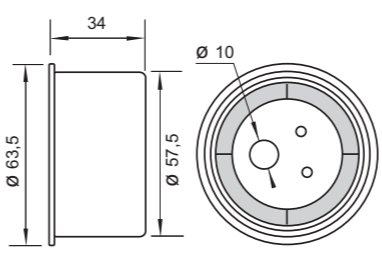
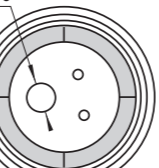
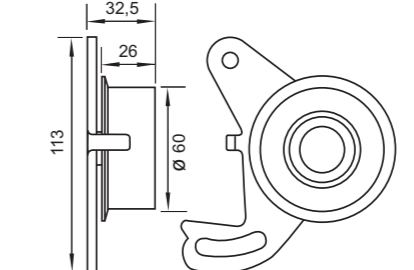
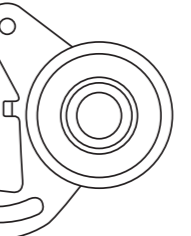
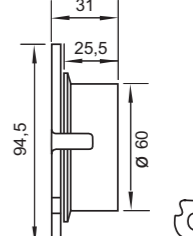
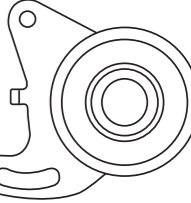
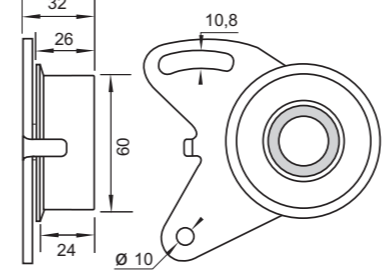
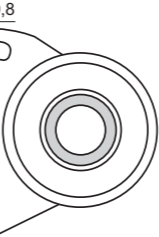
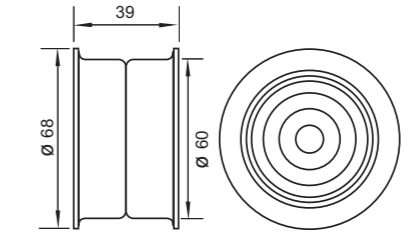
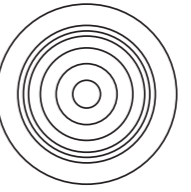
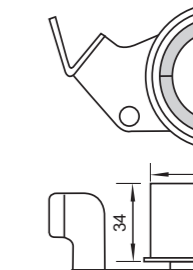
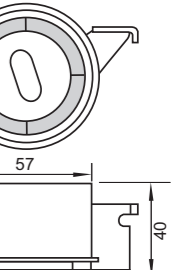
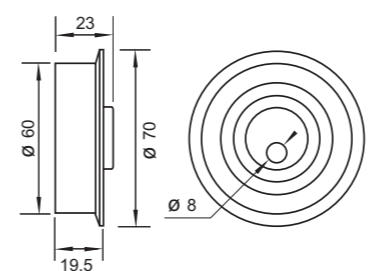
1.8	1755	N	4G37	11/88	10/92		12415 12280
1.8	1834	N	4G93	11/92	08/96		12529
2.0	1997	N	4G63 (SOHC)	04/89	10/92	1055	12305 12401
2.0	1997	N	4G63 (SOHC)	07/89	10/92	1055	12194 12206
2.0	1997	N	4G63	11/92	08/96	1055	12206 12194
2.4	2400	N	G64B	07/85	12/98		12401 12305
2.4	2400	N	4G64 (SOHC)	02/93	05/94	1055	12206 12194
2.4 GDI	2400	N	4G64	01/99		1055	12194 12206

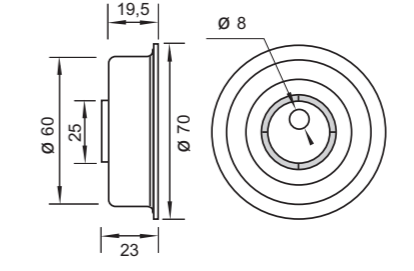
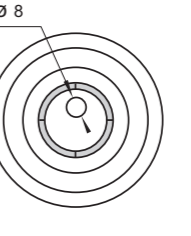
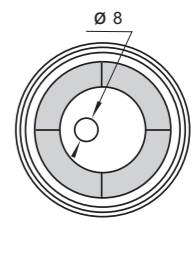
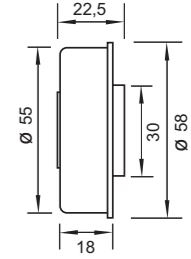
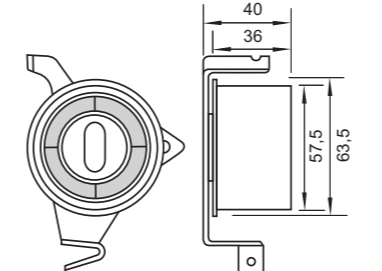
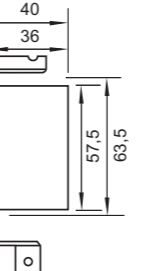
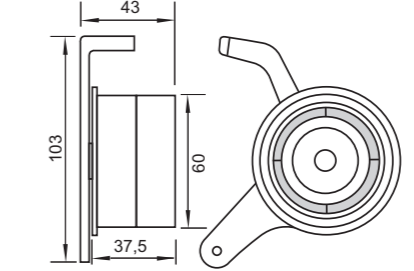
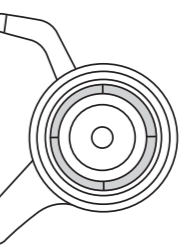
CÓDIGO CODE EM	CÓDIGO ORIGINAL ORIGINAL CODE	CÓDIGO CODE EM	CÓDIGO ORIGINAL ORIGINAL CODE	CÓDIGO CODE EM	CÓDIGO ORIGINAL ORIGINAL CODE
					
1055	MD156604	12194	MD129355=MD182537	12206	MD115976
					
12226	MD169592	12279	MD008965	12280	MD109958
					
12305	MD011536=MD040774	12309	MD012587	12323	MD320174
					
12401	MD040754	12415	MD009650	12528	MD192068
					
12529	MD175375=MD315265	12530	MD064641		

MODELO MODEL	COMB./ FUEL	MOTOR ENGINE	AÑO YEAR		CÓDIGO CODE		
			DESDE SINCE	HASTA TO	FIJO FIXED	MÓVIL MOBILE	NOTA NOTE

MITSUBISHI GALANT

2.5V6	2497	N	6G73	11/92	08/96	12306	12341	
1.8TD	1795	D	4D65T	06/84	10/92	12309	12401 12530	
2.0TD	1998	D	4D68T	11/92		12309	12530 12206	
2.3TD	2347	D	4D55T	09/80	05/84		1061 1184	

MITSUBISHI GALLOPER

3.0V6	2972	N	G6AT	02/98			12227	
2.5 D	2477	D	D4BH	02/98			1061 1184	

MITSUBISHI LANCER

1.5 12v	1468	N	4415	05/89	05/92		12413	
1.5 16v	1468	N	4415	12/95			12400	
1.6	1597	N	4G92	06/92			12529	
1.8	1755	N	4G37	09/89	06/92		12280	
1.8 16v Gti	1836	N	4G67	11/89	05/92	1055	12194 12206	
1.8 16v Gti	1834	N	4G93	06/92	12/93	1055	12226	
S.W. 1.8	1755	N	437 - 437B	01/87	06/92		12280	
2.0 16v	1997	N	4G63	01/99			12305 12401 12416	
1.8 D	1796	D	4D65	01/84	05/92	12309	12401 12530	

CÓDIGO CODE	EM	CÓDIGO ORIGINAL ORIGINAL CODE	CÓDIGO CODE	EM	CÓDIGO ORIGINAL ORIGINAL CODE	CÓDIGO CODE	EM	CÓDIGO ORIGINAL ORIGINAL CODE
12194		MD129355=MD182537	12206		MD115976	12226		MD169592
12227		MD104578	12280		MD109958	12305		MD011536=MD040774
12306		MD319022=MD151447	12309		MD012587	12341		MD140071
12400		MD030605	12401		MD040754	12413		MD146186
12416		MD129033	12529		MD175375=MD315265	12530		MD064641

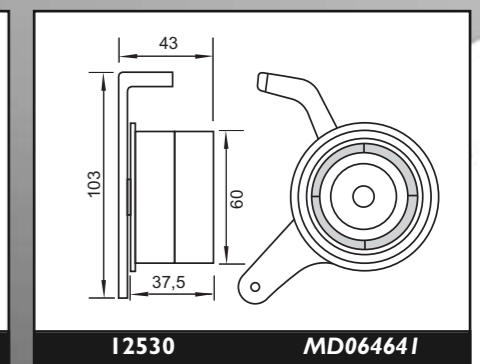
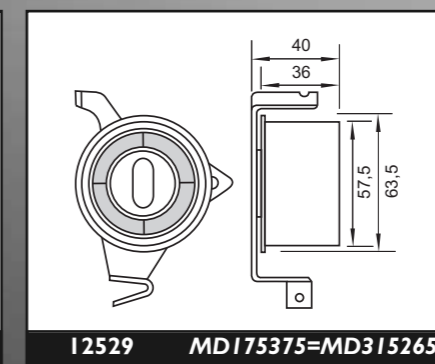
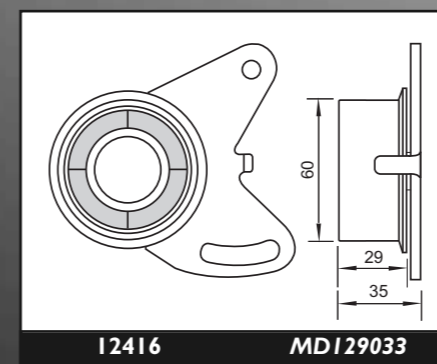
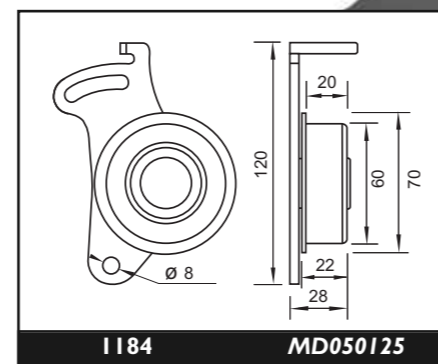
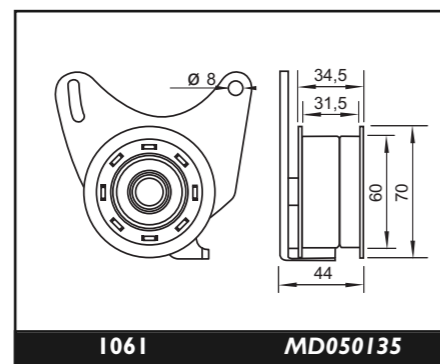
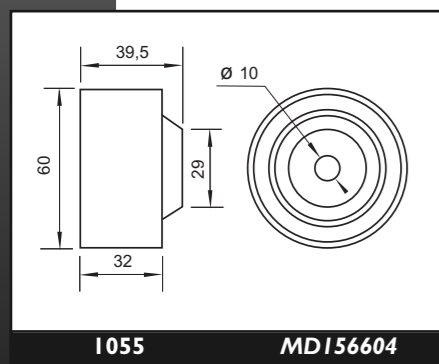

MODELO MODEL	AÑO YEAR	MOTOR ENGINE	CÓDIGO CODE			NOTA NOTE
			DESDE SINCE	HASTA TO	EM euromotor®	

MITSUBISHI LANCER

2.0 D	1998	D	4D68	06/92	11/95	12309	12206 12328
S.W. I.8 D	1796	D	4D65	09/85	06/92		12401 12530

MITSUBISHI L200 4x4

2.0	1997	N	4G63 - G36B	01/96			12531 12416
2.4	2351	N	4G64	01/96			12206 12305 12416
2.5 D	2477	D	4D56 - 4D56T	01/96			1184 1061
2.5 TD	2477	D	4D56 - 4D56T	01/96			1184 1061

MITSUBISHI MONTERO

3.0	2995	N	6G72	05/88			12227
2.3 TD	2351	D	4D55T	1983			1184 1061
2.5 TD	2477	D	4D56T				1184 1061

MITSUBISHI PAJERO PININ

1.8 GDI	1834	N		10/99		1055	12226
2.0	2000	N		01/01		1055	12226

MITSUBISHI PAJERO

1.8 GDI	1834	N	4G93 (GDI)	06/98	04/00	1055	12226
2.4	2351	N	4G64	04/91	04/00		12531 12206 12305
3.0V6	2972	N	6G72	12/90	04/00		12227
3.0V6 24v	2972	N	6G72	06/94	04/00	12306	12341
2.5 TD	2477	D	4D56T	12/90	04/00		1184 1061

CÓDIGO CODE	EM	CÓDIGO ORIGINAL ORIGINAL CODE	CÓDIGO CODE	EM	CÓDIGO ORIGINAL ORIGINAL CODE	CÓDIGO CODE	EM	CÓDIGO ORIGINAL ORIGINAL CODE
1055		MD156604	1061		MD050135	1184		MD050125
12206		MD115976	12226		MD169592	12227		MD104578
12305		MD011536=MD040774	12306		MD319022=MD151447	12309		MD012587
12328		MD174352	12341		MD140071	12401		MD040754
12416		MD129033	12530		MD064641	12531		MD128765

MODELO MODEL	COMB./ FUEL	MOTOR ENGINE	AÑO YEAR		CÓDIGO CODE		
DESDE SINCE	HASTA TO	FIJO FIXED	MÓVIL MOBILE	NOTA NOTE	EM euromotor®		

MITSUBISHI PAJERO SPORT

2.5 TD	2477	D	4D56T	11/98			1184 1061
3.0 V6	2972	N	6G72	11/98			12227

MITSUBISHI SANTAMO

2.0 16v	1997	D	4G63	1999		1055	12206 12194
---------	------	---	------	------	--	------	----------------

MITSUBISHI SAPPORO

1.6	1597	N	4G32	09/80	12/84		12279 12415
2.0	1997	N	4G63	01/81	12/83		12305 12401

MITSUBISHI SIGMA

3.0	2972	N	6G72 (SOHC)	12/90	07/96		12227
3.0 V6 24v	2972	N	6G72	12/90		12306	12341

MITSUBISHI SPACE GEAR

2.0	1997	N	4G63	05/95		1055	12206 12194
2.4i	2351	N	4G64	05/95		1055	12206 12194
2.5 D	2477	D	4D56T - 4D56TD	05/95			1184 1061
2.5 TD	2477	D	4D56T - 4D56TD	05/95			1184 1061

MITSUBISHI SPACE RUNNER

1.8	1834	N	4G93	10/91	08/99		12529
2.0 16v	1997	N	4G63	06/97		1055	12206 12194
2.4 GDI	2351	N	4G64	09/99		1055	12206 12194
2.0 TD	1998	D	4D68T	10/92	08/99	12309	12206 12328

CÓDIGO CODE	EM	CÓDIGO ORIGINAL ORIGINAL CODE	CÓDIGO CODE	EM	CÓDIGO ORIGINAL ORIGINAL CODE	CÓDIGO CODE	EM	CÓDIGO ORIGINAL ORIGINAL CODE
1055		MD156604	1061		MD050135	1184		MD050125
12194		MD129355=MD182537	12206		MD115976	12227		MD104578
12279		MD008965	12305		MD011536=MD040774	12306		MD319022=MD151447
12328		MD174352	12341		MD140071	12401		MD040754
12415		MD009650	12529		MD175375=MD315265			

MODELO MODEL	COMB./FUEL	MOTOR ENGINE	AÑO YEAR		CÓDIGO CODE		
			DESDE SINCE	HASTA TO	FIJO FIXED	MÓVIL MOBILE	NOTA NOTE

MITSUBISHI SPACE STAR

1.3 16v	I299	N	4G13	06/98	10/98		I2322
1.6 16v	I597	N	4G13	11/98			I2322
1.8 GDI	I834	N	4G93 (GDI)	06/98		I055	I2226

MITSUBISHI SPACE WAGON

1.8	I755	N	4G37	01/84	12/86		I2279 I2415
1.8	I755	N	4G37	01/87	12/88		I2415 I2280
1.8	I934	N	4G93	05/91	10/98		I2529
2.0	I997	N	G63B	06/86	04/87		I2401 I2416
2.0	I997	N	G63B	05/87	05/88		I2531 I2416
2.0	I997	N	4G63	06/88	04/91		I2531 I2305
2.0	I997	N	4G63	10/92	10/98	I055	I2206 I2194
2.4 GDI	I2351	N	4G64 (GDI)	11/98		I055	I2206 I2194
1.8 TD	I796	D	4D65	06/86	10/98	I2309	I2401 I2530
2.0 TD	I998	D	4D68	10/92	10/98	I2309	I2206 I2328

MITSUBISHI STARION

2.0 Turbo ECI	I997	N	4G63T - 4G63T/C	06/82	08/87		I2305 I2401 I2531
---------------	------	---	-----------------	-------	-------	--	-------------------------

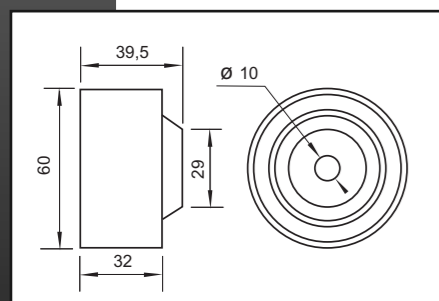

I055 MD156604

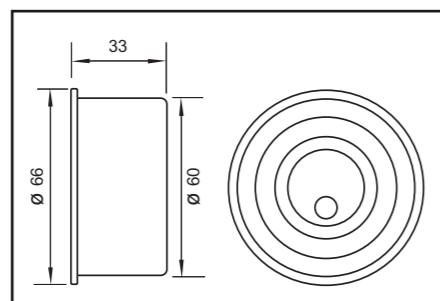

I2194 MD129355=MD182537

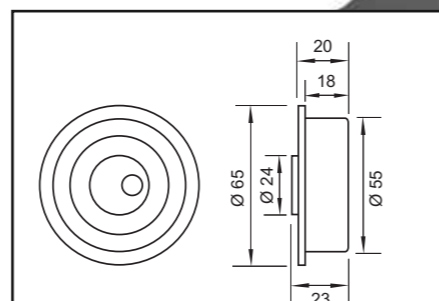

I2206 MD115976

CÓDIGO CODE	EM	CÓDIGO ORIGINAL ORIGINAL CODE
----------------	----	----------------------------------

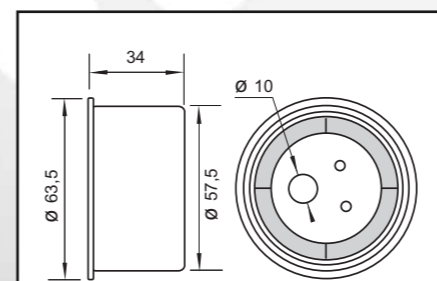

I2226 MD169592

CÓDIGO CODE	EM	CÓDIGO ORIGINAL ORIGINAL CODE
----------------	----	----------------------------------

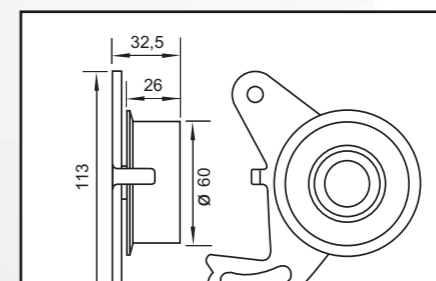

I2279 MD008965

CÓDIGO CODE	EM	CÓDIGO ORIGINAL ORIGINAL CODE
----------------	----	----------------------------------

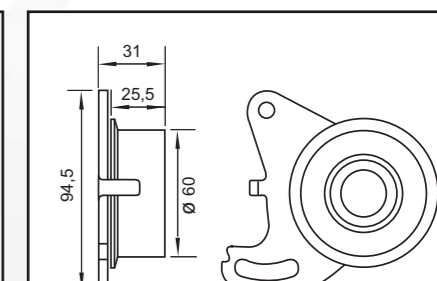

I2280 MD109958

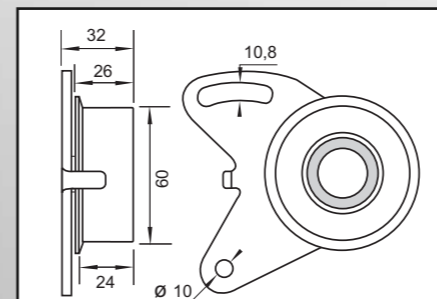

I2305 MD011536=MD040774

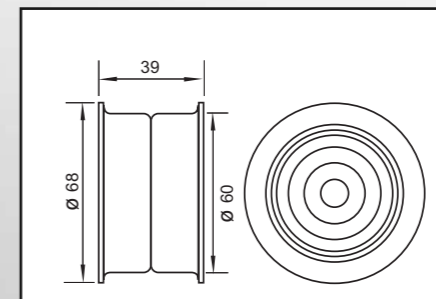

I2309 MD012587

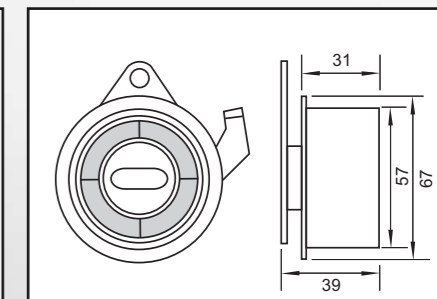

I2322 MD329976

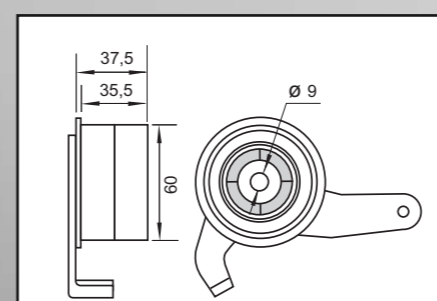

I2328 MD174352

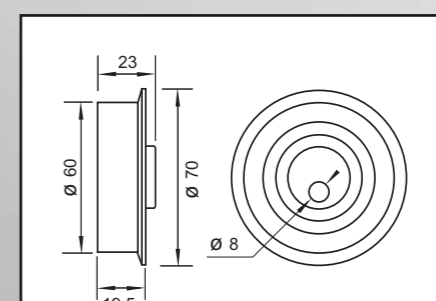

I2401 MD040754

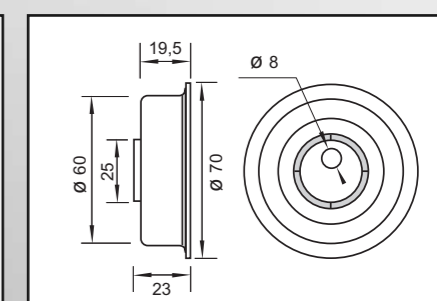

I2415 MD009650

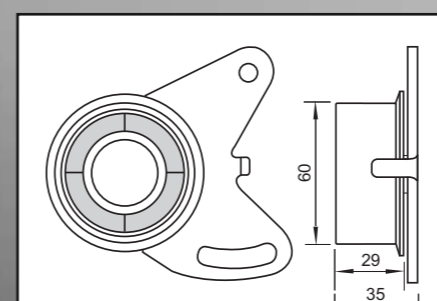

I2416 MD129033

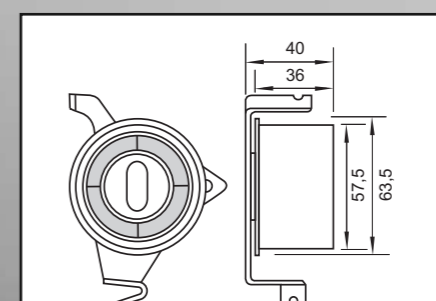

I2529 MD175375=MD315265

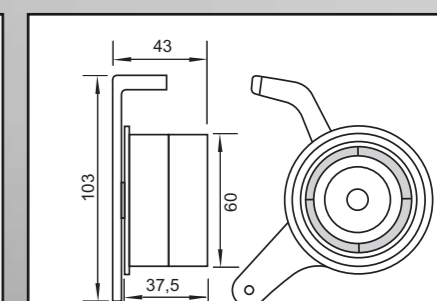

I2530 MD064641

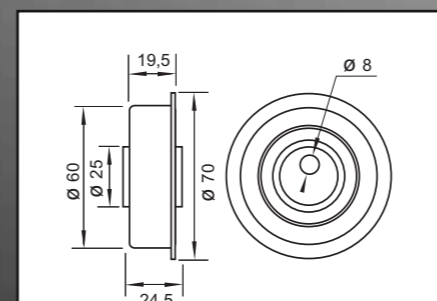

I2531 MD128765



MODELO MODEL	COMB./FUEL	MOTOR ENGINE	AÑO YEAR		CÓDIGO CODE EM euromotor®		
			DESDE SINCE	HASTA TO	FIJO FIXED	MÓVIL MOBILE	NOTA NOTE

Utilitarios

MITSUBISHI L 100 - MINICAB

550	N	3G81				12533
600	N	3G83				12533
800	N					12532
1000	N					12533 12534

MITSUBISHI L 200

1.6	1597	N	4G32	01/81	12/86	12279
1.6	1597	N	4G32	01/87	12/95	12529
2.0	1997	N	4G63 - G36B	09/81	04/87	12401 12416
2.0	1997	N	4G63 - G36B	05/87	01/91	12531 12416
2.0	1997	N	4G63 - G36B	01/96		12531 12416
2.4	2351	N	4G64	06/89	05/92	12531 12305 12416
2.4	2351	N	4G64	06/92	12/95	12206 12305 12416
2.4	2351	N	4G64	01/96		12206 12305 12416
2.3 D	2347	D	4D55	06/86	12/86	1184 1061
2.5 D	2477	D	4D56T - 4D56T	11/86	12/95	1184 1061
2.5 D	2477	D	4D56 - 4D56T	01/96		1184 1061
2.5 TD	2477	D	4D56T - 4D56T	11/86	12/95	1184 1061
2.5 TD	2477	D	4D56 - 4D56T	01/96		1184 1061

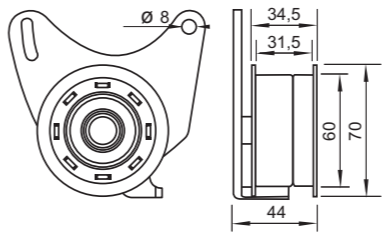
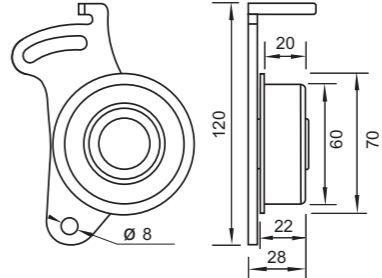
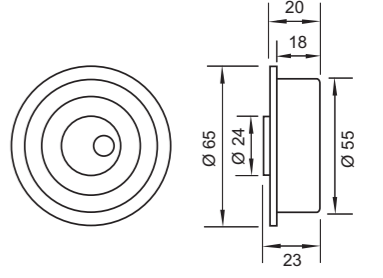
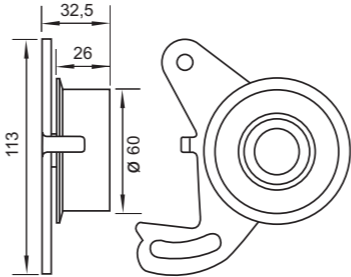
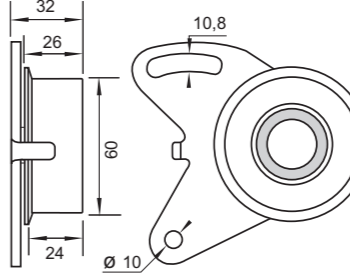
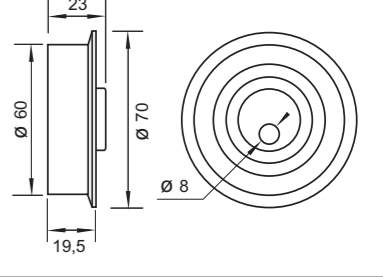
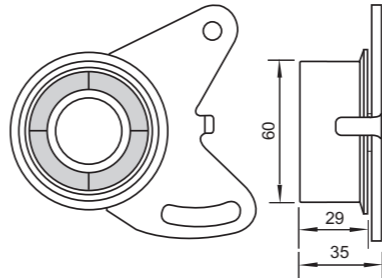
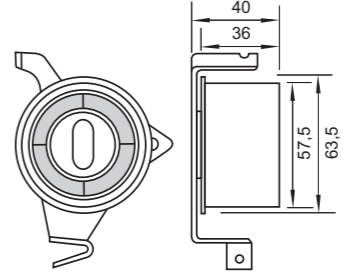
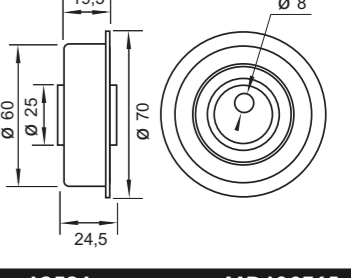
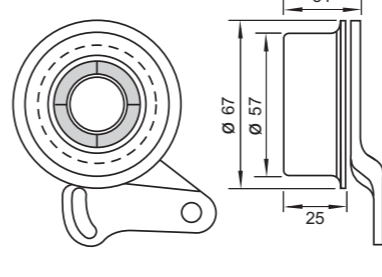
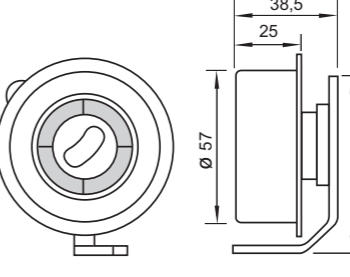
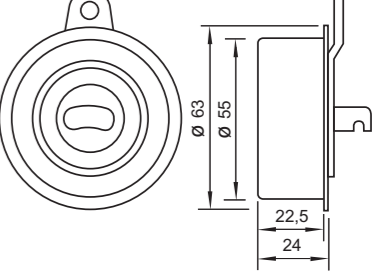
CÓDIGO CODE EM	CÓDIGO ORIGINAL ORIGINAL CODE	CÓDIGO CODE EM	CÓDIGO ORIGINAL ORIGINAL CODE	CÓDIGO CODE EM	CÓDIGO ORIGINAL ORIGINAL CODE
	MD050135		MD050125		MD115976
1061		1184		12206	
	MD008965		MD011536=MD040774		MD040754
12279		12305		12401	
	MD129033		MD175375=MD315265		MD128765
12416		12529		12531	
	MD068999		MD120266		MD114691
12532		12533		12534	

MODELO MODEL	COMB. / FUEL	MOTOR ENGINE	AÑO YEAR		CÓDIGO CODE		
			DESDE SINCE	HASTA TO	FIJO FIXED	MÓVIL MOBILE	NOTA NOTE

MITSUBISHI L 300

1.6	1597	N	4G32	09/81	04/94		12279	
1.6	1597	N	4G32	11/84	04/94		12280	
1.8	1934	N	4G62	08/84	02/87		12401 12416	
2.0	1997	N	4G63	11/86	02/87		12305 12401 12416	
2.0	1997	N	G36B - 4G63	11/86		1055	12531 12194 12305 12401 12416	
2.4	2351	N	G64B - 4G64	11/86		1055	12531 12194 12206 12305 12401 12416	
2.3 D	2347	D	4D55	04/83	10/86		1184 1061	
2.5 D	2477	D	4D56	12/86			1184 1061	

CÓDIGO CODE	EM	CÓDIGO ORIGINAL ORIGINAL CODE	CÓDIGO CODE	EM	CÓDIGO ORIGINAL ORIGINAL CODE	CÓDIGO CODE	EM	CÓDIGO ORIGINAL ORIGINAL CODE
1055		MD156604	1061		MD050135	1184		MD050125
12194		MD129355=MD182537	12206		MD115976	12279		MD008965
12280		MD109958	12305		MD011536=MD040774	12401		MD040754
12416		MD129033	12531		MD128765			

EM euromotor®

VERSION PDF 2010



$\varnothing 18$

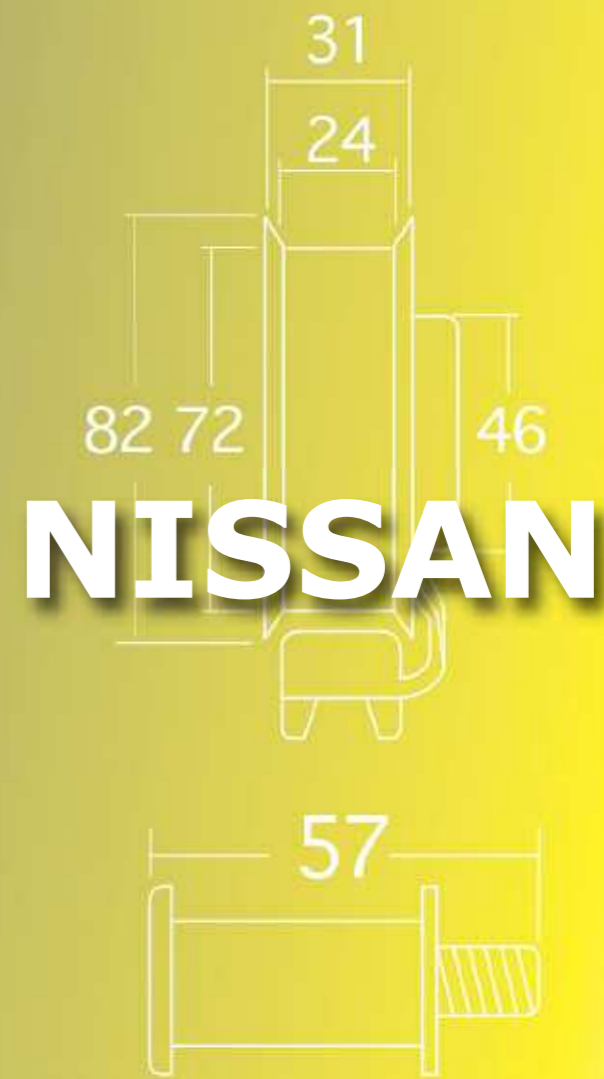

NISSAN



MODELO MODEL	COMB./ FUEL	MOTOR ENGINE	AÑO YEAR		CÓDIGO CODE		
			DESDE SINCE	HASTA TO	FIJO FIXED	MÓVIL MOBILE	NOTA NOTE

NISSAN ALMERA

1.5dci	1461	D	K9K	02/01			12298	
2.0 D	1974	D	CD20	11/95	03/00	12308	12536 12540	

NISSAN 200 SX

1.8 Turbo	1809	N	CA18ET	07/86	04/87		12326	
1.8 Turbo	1809	N	CA18DET	07/88	11/93	12541	12537	
3.0	1809	N	VG30E	07/86	04/87		12217	

NISSAN 300 ZX

3.0	2960	N	VG30E	01/84	12/87		12217	
3.0 Turbo	2960	N	VG30ET	04/84	10/90		12217	
3.0 Turbo	2960	N	VG30DEET	11/90	09/95	12552 12539	12553	2 x motor 2 x engine

NISSAN BLUBIRD

1.8	1809	N	CA18D - CA18T	02/89	05/90	12541	12537	
1.8 Turbo	1809	N	CA18D - CA18T	02/89	05/90	12541	12537	
2.0	1974	N	CA20E	04/84	12/90		12326	
2.0 D	1952	D	LD20	01/80	12/90	12538	12535	

NISSAN CEDRIC

3.0	2960	N	VG30E - VG30S	10/83	10/90		12217	
-----	------	---	---------------	-------	-------	--	-------	--

NISSAN CHERRY

1.4	1379	N	A14S	08/80	07/81		12215	
1.5	1488	N	E15S-E15T	11/83	10/86		12215	
1.5 Turbo	1488	N	E15S-E15T	11/83	10/86		12215	

CÓDIGO
CODE **EM**

CÓDIGO ORIGINAL
ORIGINAL CODE

CÓDIGO
CODE **EM**

CÓDIGO ORIGINAL
ORIGINAL CODE

CÓDIGO
CODE **EM**

CÓDIGO ORIGINAL
ORIGINAL CODE

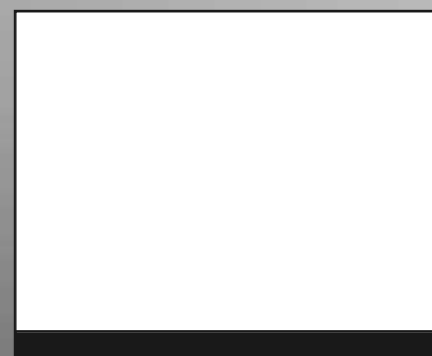
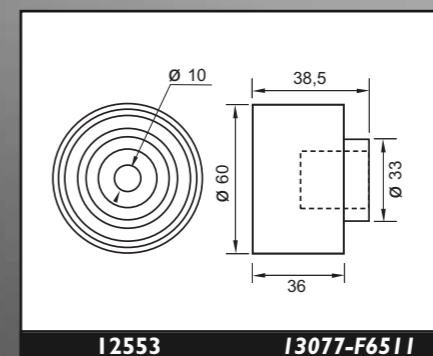
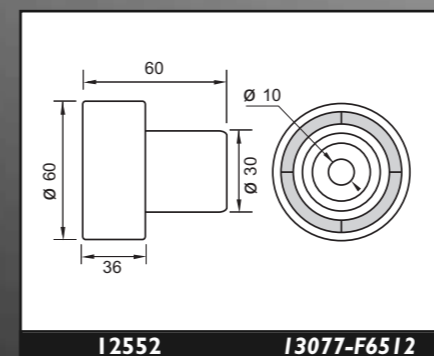
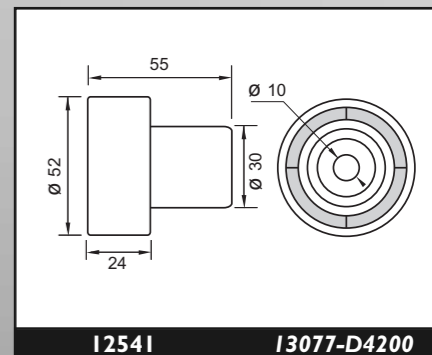
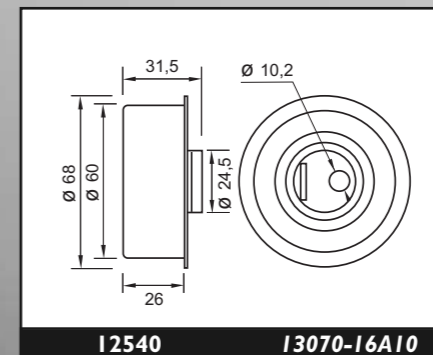
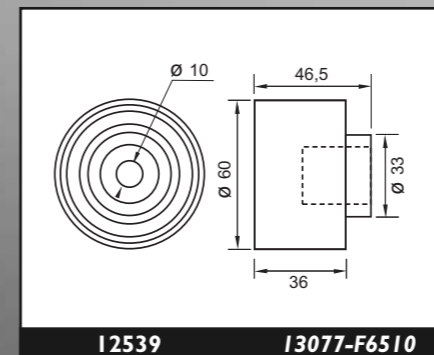
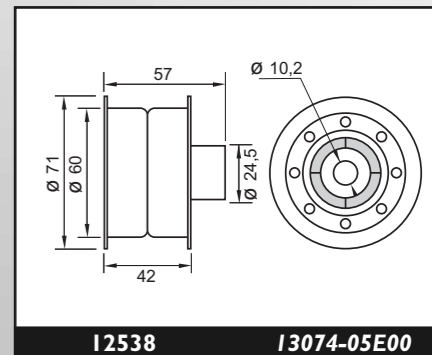
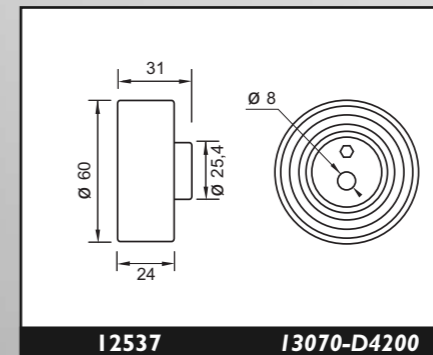
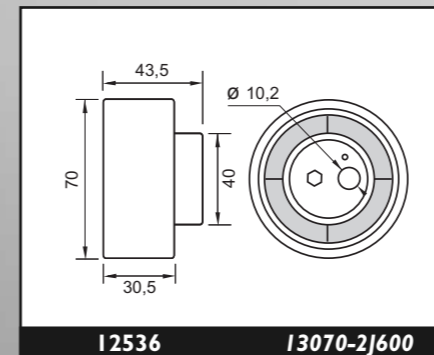
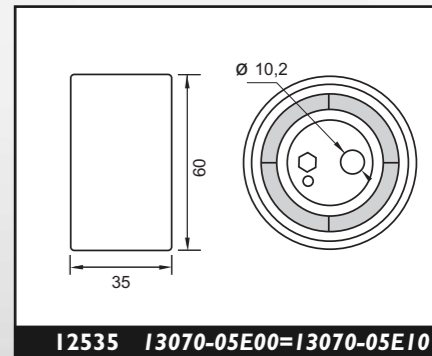
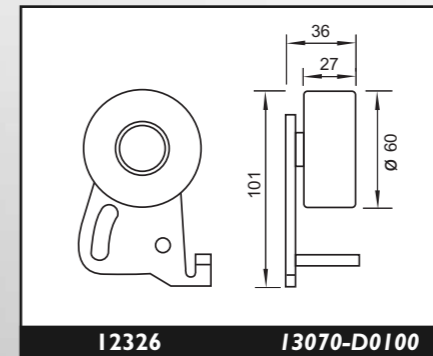
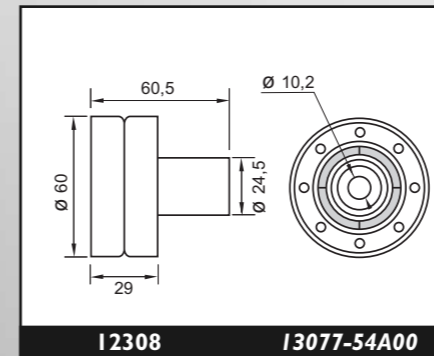
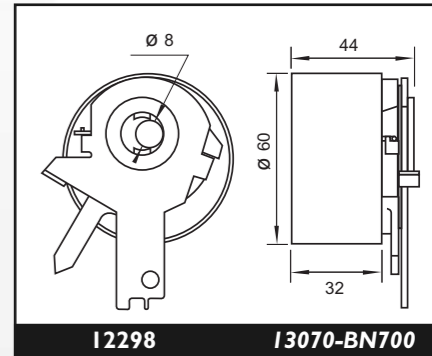
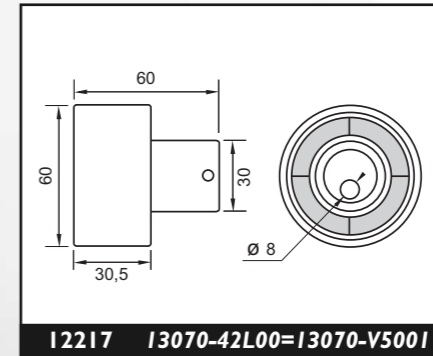
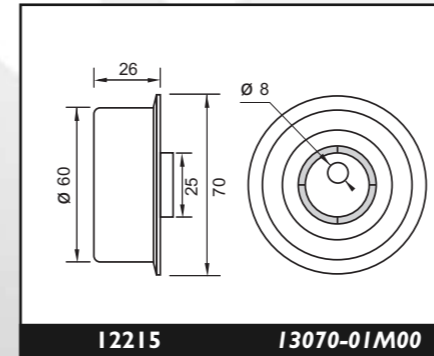

MODELO MODEL	COMB./FUEL	MOTOR ENGINE	AÑO YEAR		CÓDIGO CODE		
			DESDE SINCE	HASTA TO	FIJO FIXED	MÓVIL MOBILE	NOTA NOTE

NISSAN CHERRY

1.7 D	1681	D	CD17	10/82	12/86	12542 12540	12327
-------	------	---	------	-------	-------	----------------	-------

NISSAN MAXIMA

1.8	1809	N	CA18DET	03/89		12541	12537
2.4	2400	N	RB24S	10/88	06/94		12217
3.0	2960	N	VG30E	10/88	06/94		12217

NISSAN MICRA

1.5 D	1527	D	TUD5 -VJZ	02/98	02/03	1862	1861
1.5 dci	1461	D	K9K	01/03			12298

NISSAN PATROL

2.8 TD	2826	D	RD28T	09/88	06/97	12313	12312
3.0	2960	N	VG30E	09/88	06/91		12217

NISSAN PATROL GR1

2.8 TD	2826	D	RD28T	05/86	11/95	12313	12312
--------	------	---	-------	-------	-------	-------	-------

NISSAN PATROL GR2

2.8 TD	2826	D	RD28ETI	07/97	05/00	12313	12312
--------	------	---	---------	-------	-------	-------	-------

NISSAN PATHFINDER

3.0	2960	N	VG30E	07/86	05/94		12217
-----	------	---	-------	-------	-------	--	-------

NISSAN PRAIRE

1.5	1488	N	E15S	01/84	12/87		12215
1.8	1809	N	CA18S	07/83	10/87		12326
2.0	1974	N	CA20S	06/86	09/88		12326

NISSAN PRAIRE PRO

2.0	1974	N	CA20E	10/88	12/92	12308	12536 12326 12540
-----	------	---	-------	-------	-------	-------	-------------------------

CÓDIGO EM CÓDIGO ORIGINAL ORIGINAL CODE

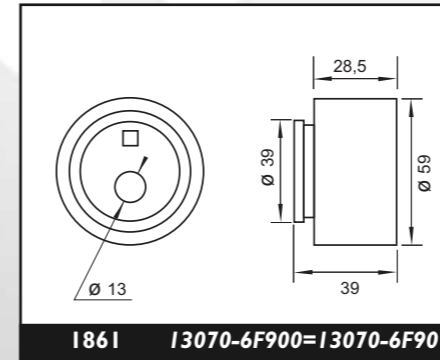

CÓDIGO EM CÓDIGO ORIGINAL ORIGINAL CODE

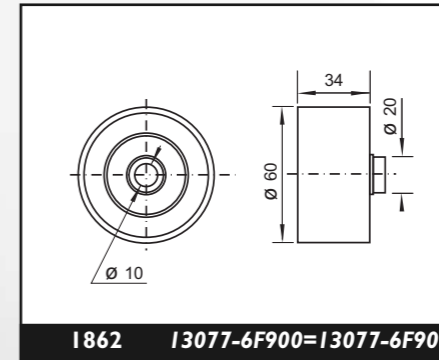

CÓDIGO EM CÓDIGO ORIGINAL ORIGINAL CODE

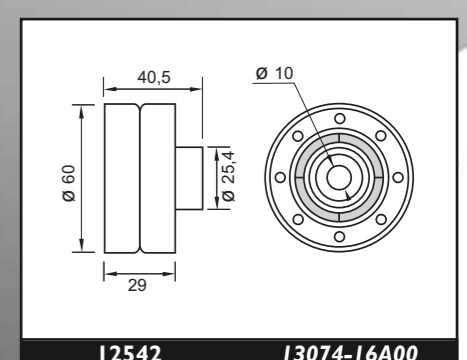
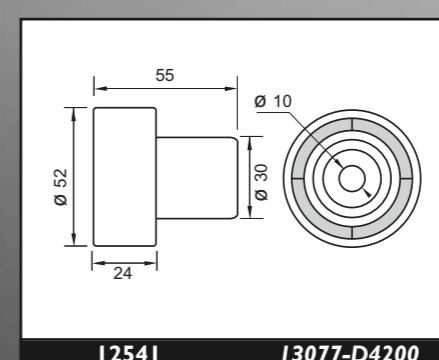
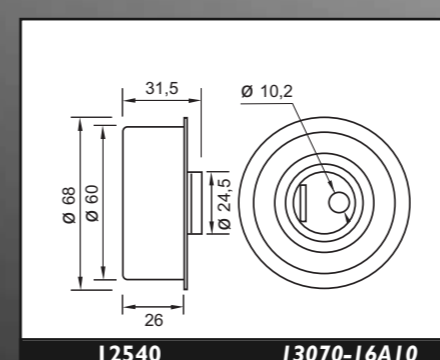
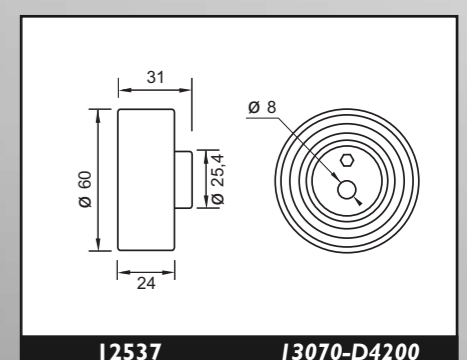
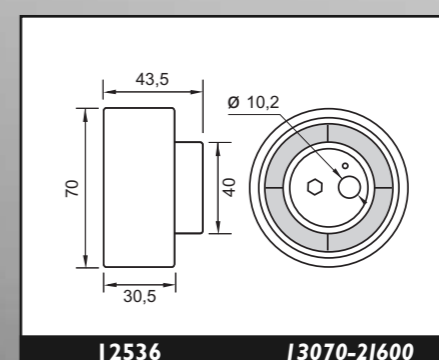
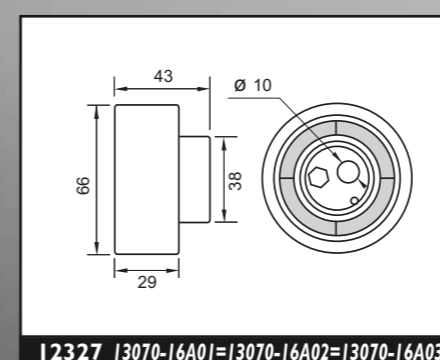
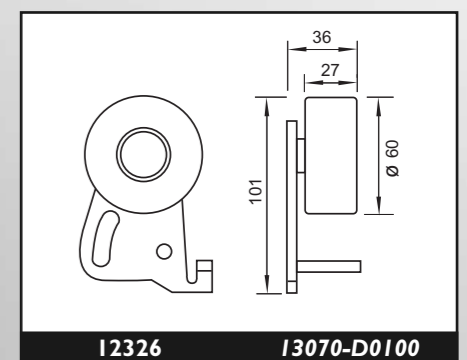
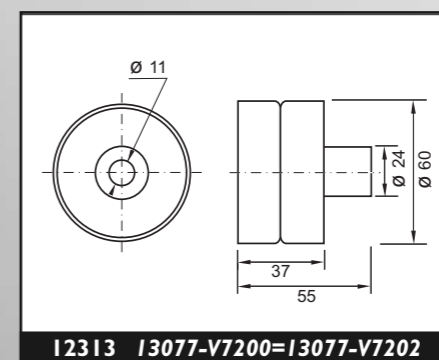
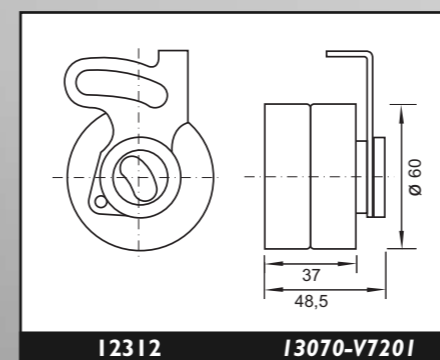
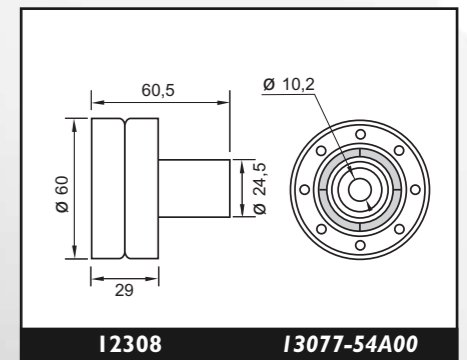
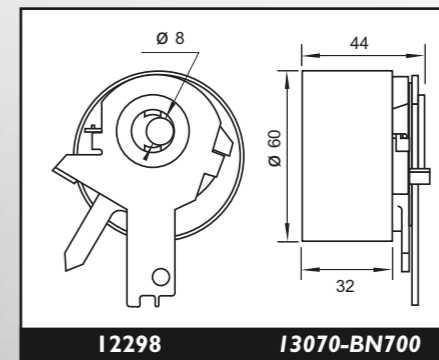
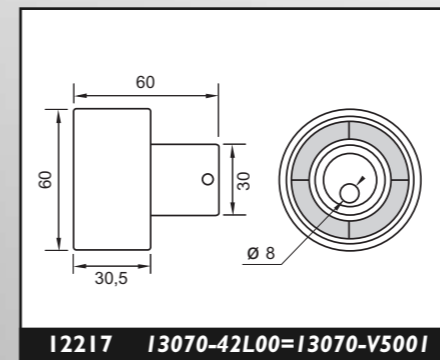
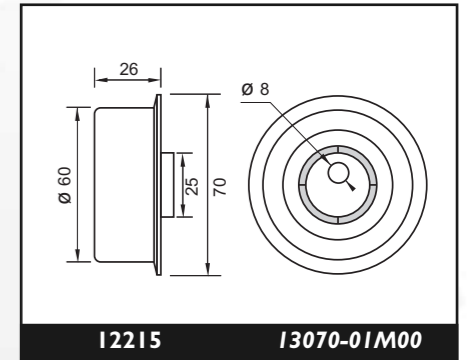

MODELO MODEL	AÑO YEAR	MOTOR ENGINE	CÓDIGO CODE		FIJO FIXED	MÓVIL MOBILE	NOTA NOTE
			DESDE SINCE	HASTA TO			

NISSAN PRIMERA

2.0 D	1974	D	CD20	07/90	01/96	12308	12536 12540
2.0 TD	1974	D	CD20T	09/96	09/97	12543	12536 12540
2.0 TD	1974	D	CD20T	10/97		12543	12536

NISSAN PULSAR

1.6	1598	N	EI6S-EI6I/S	06/85	08/90		12215
1.6	1598	N	CA16D	02/87	10/88	12541	12537
1.8	1809	N	CA18DE	10/88	08/90	12541	12537
1.7 D	1681	D	CD17	10/82	07/86	12542	12327 12540
1.7 D	1681	D	CD17	08/86	08/90	12308	12327 12540
2.0 D	1974	D	CD20	10/90		12308	12536 12540

NISSAN SENTRA

1.5	1488	N	EI5S	04/82	08/90		12215
1.6	1598	N	EI6S-EI6I/S	06/85	08/90		12215
1.6	1598	N	CA16D	02/87	10/88	12541	12537
1.8	1809	N	CA18DE	10/88	08/90	12541	12537
1.7 D	1681	D	CD17	10/82	07/86	12542	12327 12540
1.7 D	1681	D	CD17	08/86	08/90	12308	12327 12540
2.0 D	1974	D	CD20	10/90		12308	12327 12540

NISSAN SERENA

2.0 D	1974	D	LD20	11/92		12538	12535
2.3 D	2283	D	CD23	01/95		12538	12535

CÓDIGO CODE	EM	CÓDIGO ORIGINAL ORIGINAL CODE	CÓDIGO CODE	EM	CÓDIGO ORIGINAL ORIGINAL CODE	CÓDIGO CODE	EM	CÓDIGO ORIGINAL ORIGINAL CODE
12215		I3070-01M00	12308		I3077-54A00	12327		I3070-16A01=I3070-16A02=I3070-16A03
12535		I3070-05E00=I3070-05E10	12536		I3070-2J600	12537		I3070-D4200
12538		I3074-05E00	12540		I3070-16A10	12541		I3077-D4200
12542		I3074-16A00	12543		I3077-54A02			

MODELO MODEL	COMB./FUEL	MOTOR ENGINE	AÑO YEAR		CÓDIGO CODE		
			DESDE SINCE	HASTA TO	FIJO FIXED	MÓVIL MOBILE	NOTA NOTE

NISSAN SUNNY

1.6	1598	N	EI6S-EI6I/S	06/86	10/90		12215
1.6	1598	N	CA16D	02/87	10/88	12541	12537
1.8	1809	N		02/87	10/88	12541	12537
1.8	1809	N	CA18D	10/88	08/90	12541	12537
1.7 D	1681	D	CD17	03/82	05/89	12542	12327 12540
1.7 D	1681	D	CD17	08/86	08/90	12308	12327 12540
2.0 D	1974	D	CD20	10/90	12/95	12308	12327 12540

NISSAN TERRANO

3.0	2960	N	VG301	07/86	08/89		12217
-----	------	---	-------	-------	-------	--	-------

NISSAN TERRANO 2

3.0	2960	N	VG30E	01/90	12/95		12217
-----	------	---	-------	-------	-------	--	-------

NISSAN TIIDA

1.6 16v	1598	N	K4M	09/07		12208	12177
1.5 DCI	1461	D	K9K 700	09/07			12298

Utilitarios

NISSAN AD MAX Van

1.7 D	1681	D	CD17	05/92	07/95	12308	12327 12540
-------	------	---	------	-------	-------	-------	----------------

NISSAN SUNNY

2.0 D	1974	D	CD20	05/92	07/95	12308	12327 12540
-------	------	---	------	-------	-------	-------	----------------

NISSAN CARAVAN

3.0	2960	N	VG30E	10/88	10/90		12217
2.0 D	1974	D	LD20T	09/86	10/90	12538	12535

CÓDIGO EM CÓDIGO ORIGINAL ORIGINAL CODE

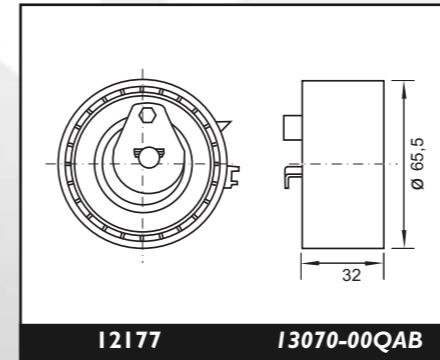

CÓDIGO EM CÓDIGO ORIGINAL ORIGINAL CODE

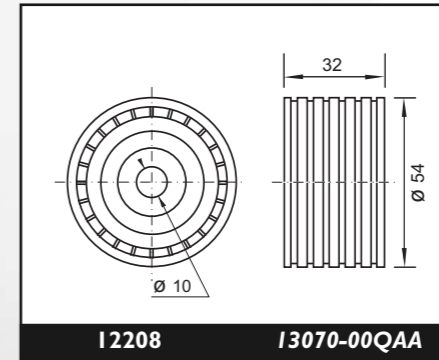

CÓDIGO EM CÓDIGO ORIGINAL ORIGINAL CODE

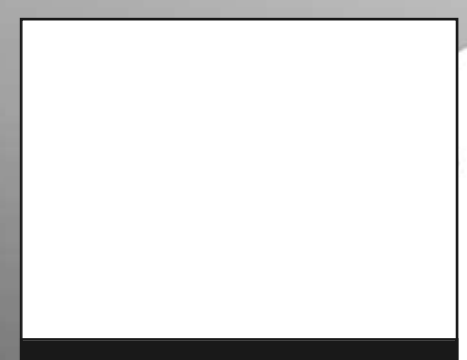
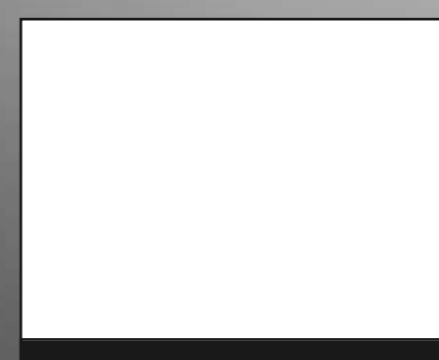
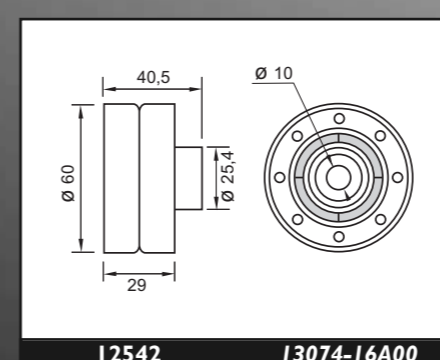
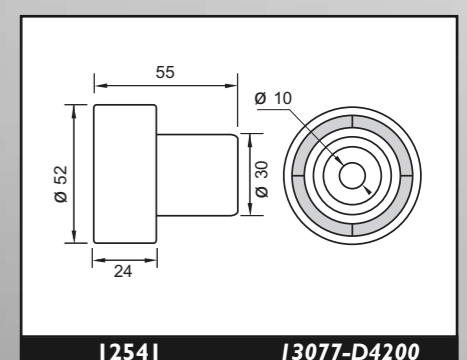
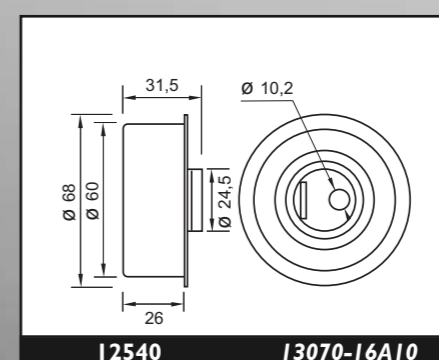
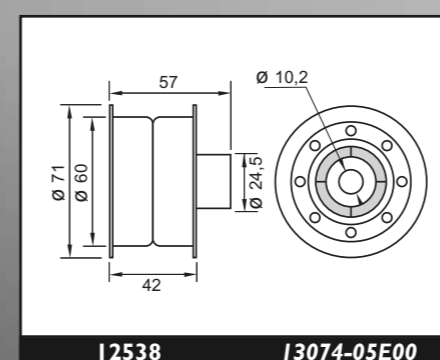
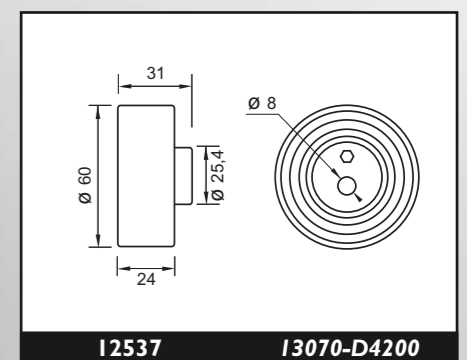
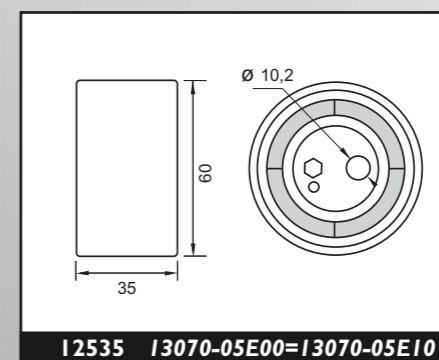
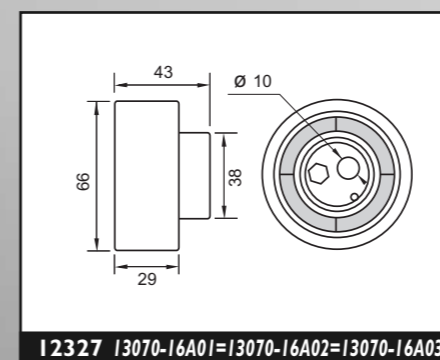
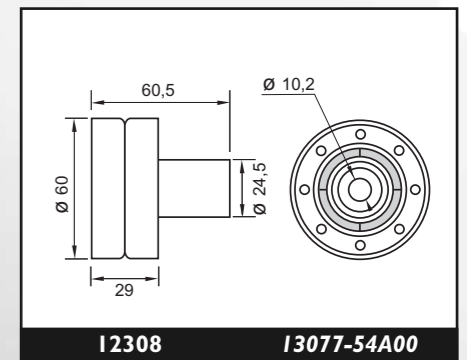
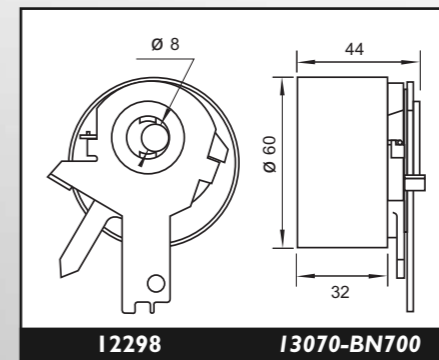
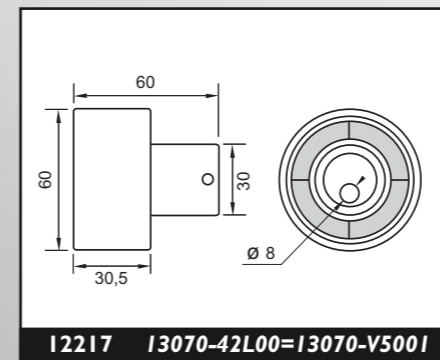
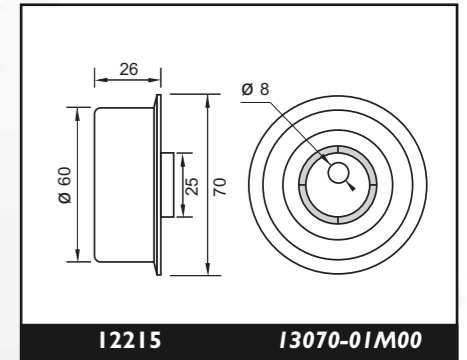

MODELO MODEL	AÑO YEAR	MOTOR ENGINE	CÓDIGO CODE		FIJO FIXED	MÓVIL MOBILE	NOTA NOTE
			DESDE SINCE	HASTA TO			

NISSAN CHERRY VANETTE

2.0 D	1974	D	LD20T	07/86	01/90	I2538	I2535
-------	------	---	-------	-------	-------	-------	-------

NISSAN HOMY VAN

3.0	2960	N	VG30E	10/88	10/90		I2217
2.0 D	1974	D	LD20T	09/86	10/90	I2538	I2535

NISSAN PICKUP

3.0	2960	N	VG30E	11/85	11/94		I2217
-----	------	---	-------	-------	-------	--	-------

NISSAN TRUCK

3.0	2960	N	VG30E	11/85	11/94		I2217
-----	------	---	-------	-------	-------	--	-------

NISSAN URVAN

3.0	2960	N	VG30E	10/88	10/90		I2217
2.0 D	1974	D	LD20T	09/86	10/90	I2538	I2535

NISSAN VANETTE

2.0 D	1974	D	LD20	07/86	03/93	I2538 I2538	I2535
2.3 D	2283	D	CD23	01/95		I2538 I2538	I2535

NISSAN PRIMASTAR

2.0 16v	1998	N	F4R	03/01		I2424 I2246	I2261
---------	------	---	-----	-------	--	----------------	-------

NISSAN TRADE

2.0 D	1974	D	LD20	07/86		I2538 I2538	I2535
2.3 D	2283	D	CD23	07/86		I2538 I2538	I2535

CÓDIGO CODE	EM	CÓDIGO ORIGINAL ORIGINAL CODE	CÓDIGO CODE	EM	CÓDIGO ORIGINAL ORIGINAL CODE	CÓDIGO CODE	EM	CÓDIGO ORIGINAL ORIGINAL CODE
12217		I3070-42L00=I3070-V5001	12246		82000-64664	12261		82000-86697
12424		82004-83288	12535		I3070-05E00=I3070-05E10	12538		I3074-05E00

EM euromotor®

VERSION PDF 2010



Ø18

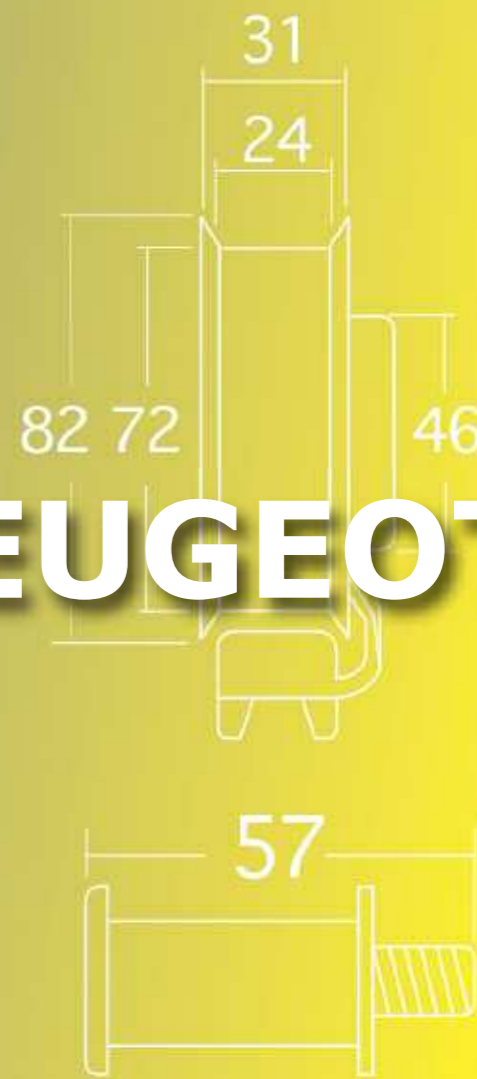

PEUGEOT



MODELO MODEL	COMB./ FUEL	MOTOR ENGINE	AÑO YEAR		CÓDIGO CODE EM euromotor®		
			DESDE SINCE	HASTA TO	FIJO FIXED	MÓVIL MOBILE	NOTA NOTE

PEUGEOT 106

1.0	954	N	TU9	09/91			1811	
1.1	1124	N	HDZ/Y(TUIM) - HFX	09/91			1811	
1.4	1360	N	TU3	09/91			1811	
1.6	1587	N	TU5J2 - TU5JP	09/91			1811	
1.6 SI6	1587	N	NFX (TU5J4)	06/96		1122	1121	
1.4 D	1527	D	K9Y (TUD3Y)	09/92		1122	1121	
1.5 D	1527	D	VJY (TUD5)	06/94		1122	1121	

PEUGEOT 205

1.0	954	N	TU9	01/87	09/98		1811	
1.1	1124	N	TU1	01/87	09/98		1811	
1.4	1360	N	TU3	01/87	09/98		1811	
1.6	1580	N	XU5	10/87	01/92		1812	
1.6	1580	N	XU5	02/92	09/98		1811	
1.6 GTI	1580	N	XU5	10/87	01/92		1812	
1.6 GTI	1580	N	XU5	02/92	09/98		1811	
1.9 GTI	1905	N	XU9	10/87	01/92		1812	
1.9 GTI	1905	N	XU9	02/92	09/98		1811	
1.7 D	176	D	161 A (XUD7)	03/83	06/93	1814	1813	
1.7 D	1769	D	161A (XUD7)	07/93	09/98	1900	1901	
1.9 D	1905	D	XUD9	10/87	06/93	1814	1813	
1.9 D	1905	D	XUD9	07/93	09/98	1900	1901	
1.9 TD	1905	D	XUD9	10/87	06/93	1814	1813	
1.9TD	1905	D	XUD9	07/93	09/98	1900	1901	

PEUGEOT 206

1.1	1124	N	HFZ (TU1M)	09/98			1811	
1.4	1360	N	KFX (TU3JP)	09/98			1811	

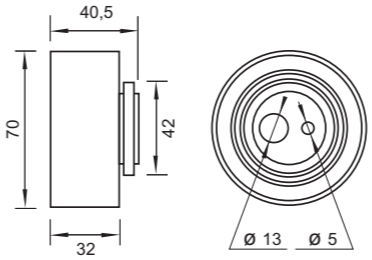
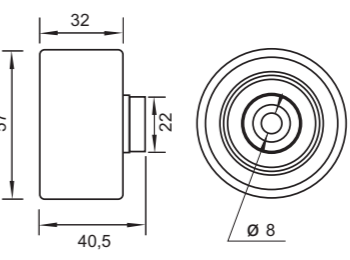
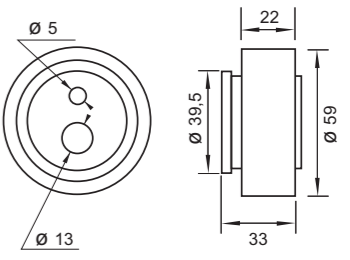
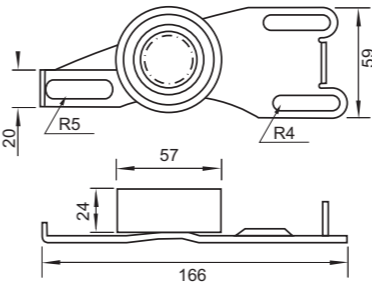
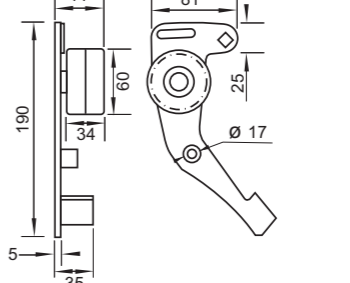
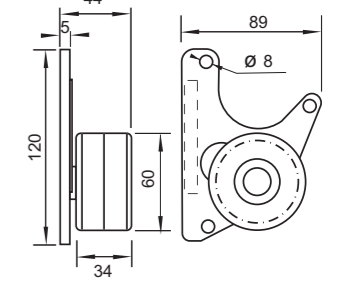
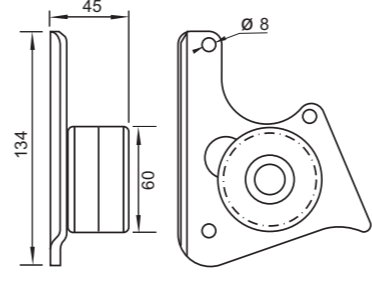
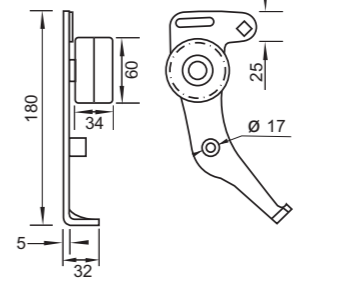
CÓDIGO CODE EM	CÓDIGO ORIGINAL ORIGINAL CODE	CÓDIGO CODE EM	CÓDIGO ORIGINAL ORIGINAL CODE	CÓDIGO CODE EM	CÓDIGO ORIGINAL ORIGINAL CODE
	0829.49		0830.20		0829.19=9605266280
1121		1122		1811	
	0829.12		0829.11=0829.21		0830.02=93501405
1812		1813		1814	
	0830.13=9615923380		0829.47=9617188680		
1900		1901			

MODELO MODEL	COMB./FUEL	MOTOR ENGINE	AÑO YEAR		CÓDIGO CODE EM euromotor®		
			DESDE SINCE	HASTA TO	FIJO FIXED	MÓVIL MOBILE	NOTA NOTE

PEUGEOT 206

1.4 16v	I360	N	ET3J4	02/02		I2545	I2544	
1.6	I587	N	NFZ (TU5JP)	09/98			I811	
1.6 16v	I587	N	TU5J4	06/96		I122	I121	
1.6 16v	I587	N	NFU	08/00		I122	I2451	Hasta motor Up to engine 1806404
1.6 16v	I587	N	NFU (TU5JP4)	07/01		I2594	I2551	Desde motor From engine 1806405
2.0 16v	I997	N	RFR	04/99		I122	I121	
1.4 HDi	I398	D	DV4TD	08/00		I2377	I2498	
1.9 D	I867	D	WJZ - DW8	09/98		I119	I118	
1.9 D	I867	D	WJZ - DW8	09/98		I2094	I2093	
2.0 HDi	I997	D	RHY - DW10TD	09/98		I2094	I2093	

PEUGEOT 207

1.4 8v	360	N	TU3JP	2008			I8119	
1.4 16v	I360	N	ET3J4	2008		I2545	I2544	
1.6 16v	I587	N	TU5JP4S	2008		I2594	I2551	
1.9 D	I867	D	DW8	2008		I2094	I2093	
2.0 HDI	I997	D	DW10TD	2008		I2094	I2093	

PEUGEOT 305

1.6	I580	N	XU5	10/82	06/88		I812	
1.9	I905	N	XU9	10/82	12/88		I812	
1.9 D	I905	D	XUD9	10/82	07/88	I814	I813	

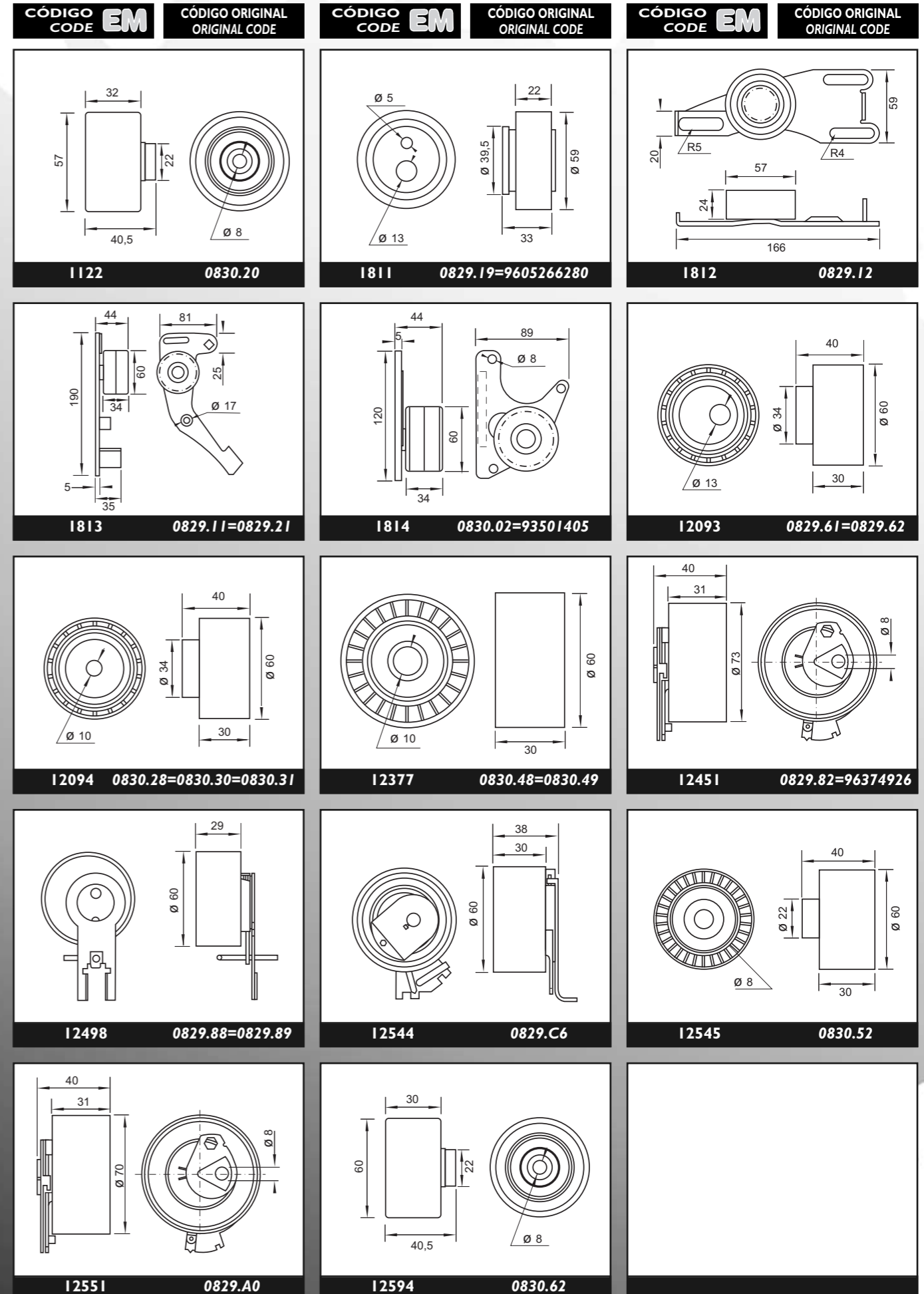
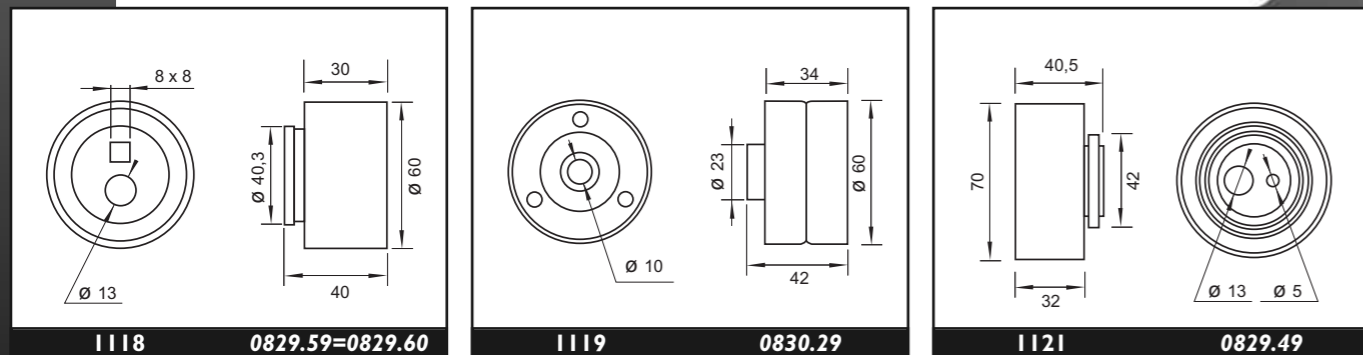

MODELO MODEL	COMB./FUEL	MOTOR ENGINE	AÑO YEAR		CÓDIGO CODE			NOTA NOTE
			DESDE SINCE	HASTA TO	FIJO FIXED	MÓVIL MOBILE	CÓDIGO ORIGINAL ORIGINAL CODE	

PEUGEOT 306

1.1i	I124	N	HDZ (TU1M)	05/93			1811	
1.4i	I360	N	KDX - KFX (TU3)	05/93			1811	
1.6	I587	N	NFZ (TU5JP)	05/93			1811	
1.8i	I761	N	LFZ (XU7JP)	05/93			1811	
1.8i 16v	I761	N	LFY (XU7JP4)	03/97		1862	1943	
1.8i 16v	I761	N	LFY	03/97		1862	92100	Desde motor From engine 8070
2.0 Xsi	I998	N	RFX (XU10J2C)	05/93			1811	121 CV
2.0 16v	I998	N	RFV (XU10J4R)	03/97		1862	1943	
2.0i 16v	I998	N	RFT- RFY (XU10J4Z)	05/93		1862	1869 12276	
2.0i 16v	I998	N	RFS (XU10J4RS)	03/96		1862	1943	
1.8 D	I769	D	A9A (XUD7)	09/98		1900	1901	
1.9 D	I868	D	WJZ - WJY (DW8)	09/98		12094	12093	
1.9 D	I905	D	XUD9	05/93	06/93	1814	1813	
1.9 D	I905	D	XUD9	07/93		1900	1901	
1.9 TD	I905	D	XUD9	05/93	06/93	1814	1813	
1.9 TD	I905	D	XUD9	07/93		1900	1901	
2.0 HDI	I997	D	RHY (DW10)	02/99		12094	12093	

PEUGEOT 307

1.4 16v	I360	N	KFW (TU3JT)	08/00			1811	Hasta motor Up to engine 3666766
1.4 16v	I360	N	KFW (TU3JT)	08/00			12376	Desde motor From engine 3666767

CÓDIGO CODE	EM	CÓDIGO ORIGINAL ORIGINAL CODE	CÓDIGO CODE	EM	CÓDIGO ORIGINAL ORIGINAL CODE	CÓDIGO CODE	EM	CÓDIGO ORIGINAL ORIGINAL CODE
1811	0829.19=9605266280		1813	0829.11=0829.21		1814	0830.02=93501405	
1862	9609908980=0830.11=0830.14		1869	0829.20=0829.42		1900	0830.13=9615923380	
1901	0829.47=9617188680		1943	0829.32		12093	0829.61=0829.62	
12094	0830.28=0830.30=0830.31		12276	0829.31=0829.46=9613700180		12376	0829.90=0829.91	
92100	0829.69=9635336880							

MODELO MODEL	COMB./ FUEL	MOTOR ENGINE	AÑO YEAR		CÓDIGO CODE EM euromotor®		
			DESDE SINCE	HASTA TO	FIJO FIXED	MÓVIL MOBILE	NOTA NOTE

PEUGEOT 307

1.4 16v	I360	N	ET3J4	02/04		I2545	I2544	
1.6 16v	I587	N	NFU	08/00		I122	I2451	Hasta motor <i>Up to engine</i> I806404
1.6 16v	I587	N	NFU (TU5JP4)	07/01		I2594	I2551	Desde motor <i>From engine</i> I806405
1.6 16v	I587	N	TU5JP4S			I2094	I2093	
2.0 16v	I997	N	EW10J4S			92102	I2334	
2.0 16v	I997	N	RFN	08/00		92102	I2334	
1.4 HDi	I398	D	DV4TD	08/00		I2377	I2498	
2.0 HDi	I997	D	DW10TD	08/00		I2094	I2093	
2.0 HDi	I997	D	DW10BTED	01/04		I2507	I2522	
2.0 HDi	I997	D	DW10BTD	2006		I2094	I2093	

PEUGEOT 309

1.1	I124	N	EI-HDZ	10/85	12/93		1811	
1.3	I298	N	GIA	10/85	12/93		1811	
1.4	I360	N	KID	03/89	03/93		1811	
1.6	I580	N	BIA	10/85	07/89		1812	
1.9		N	D2B	10/85	07/89		1812	
1.8 D	I769	D	I61 A (XUD7)	07/89	06/93	I814	I813	

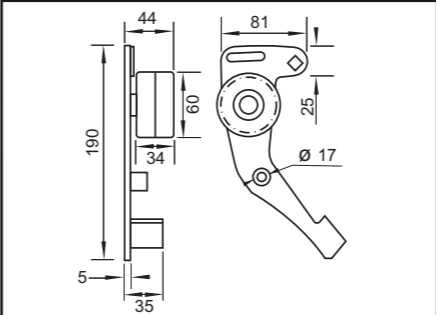
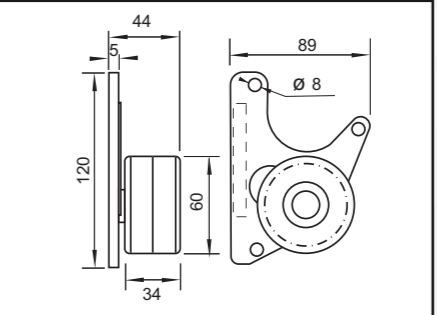
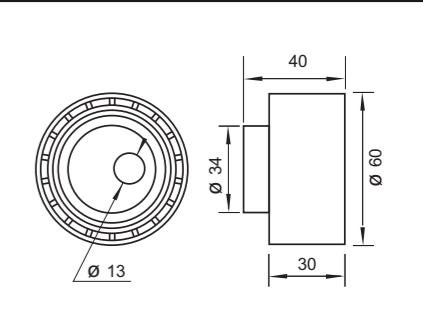
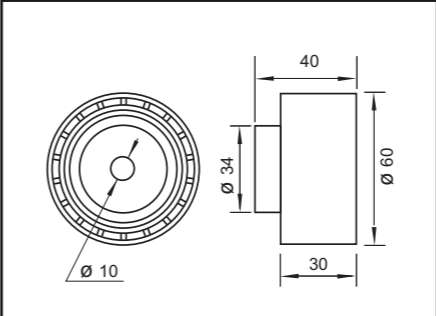
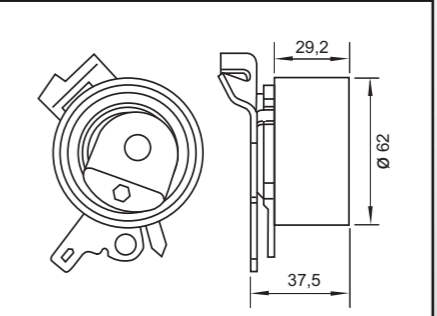
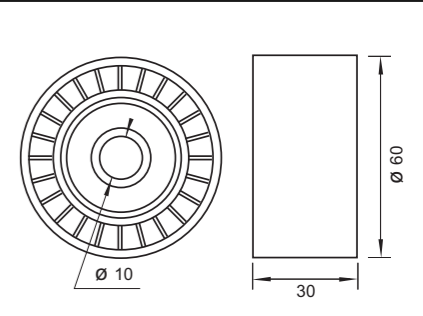
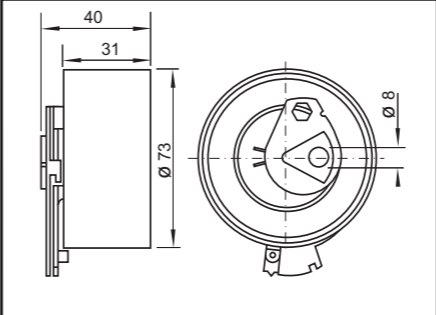
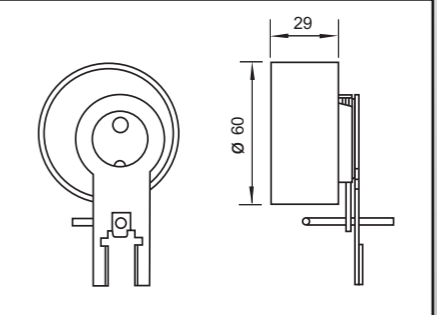
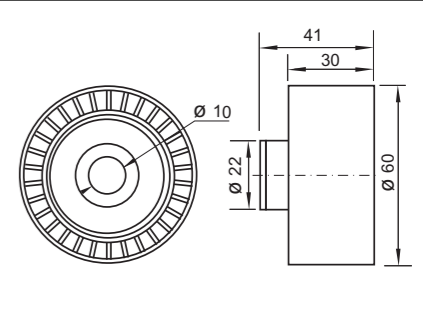
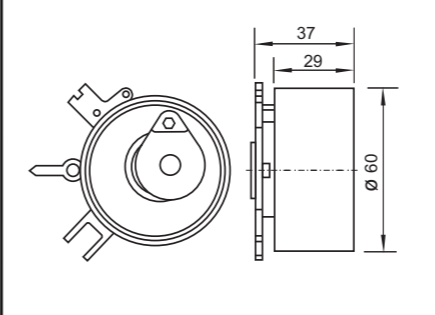
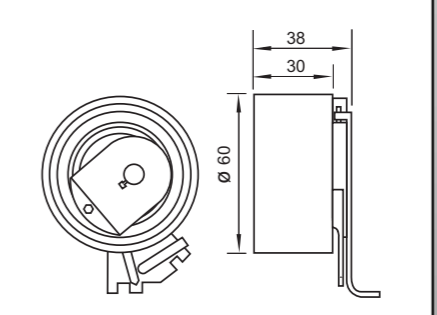
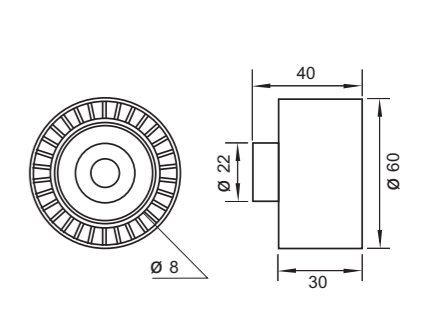
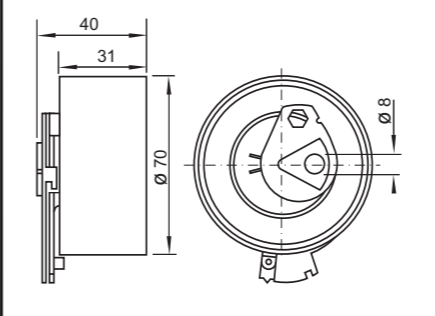
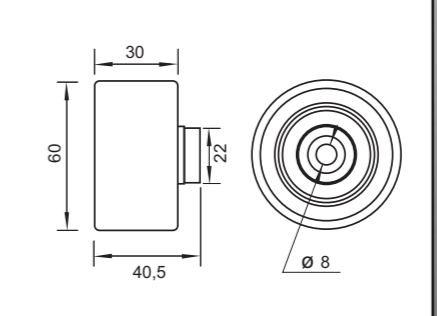
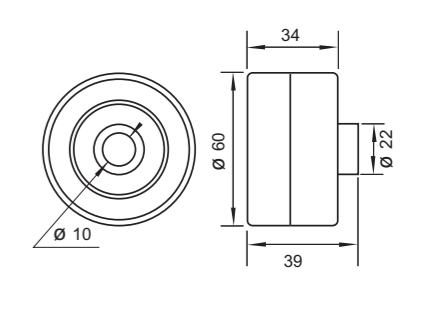
CÓDIGO CODE EM	CÓDIGO ORIGINAL ORIGINAL CODE	CÓDIGO CODE EM	CÓDIGO ORIGINAL ORIGINAL CODE	CÓDIGO CODE EM	CÓDIGO ORIGINAL ORIGINAL CODE
					
1813	0829.11=0829.21	1814	0830.02=93501405	12093	0829.61=0829.62
					
12094	0830.28=0830.30=0830.31	12334	0829.77=9400829969	12377	0830.48=0830.49
					
12451	0829.82=96374926	12498	0829.88=1145947	12507	0830.51=9400829969
					
12522	0829.A4	12544	0829.C6	12545	0830.52
					
12551	0829.A0	12594	0830.62	92102	0830.42=9400830429

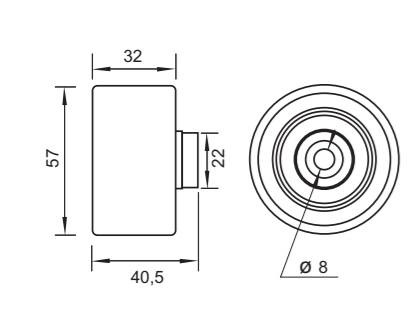

1122 **0830.20**

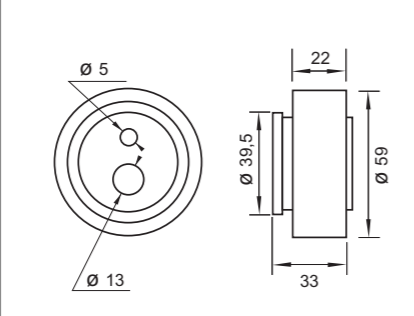

1811 **0829.19=9605266280**

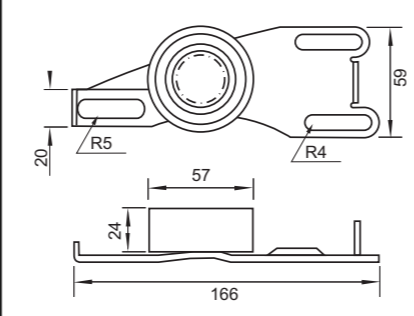

1812 **0829.12**

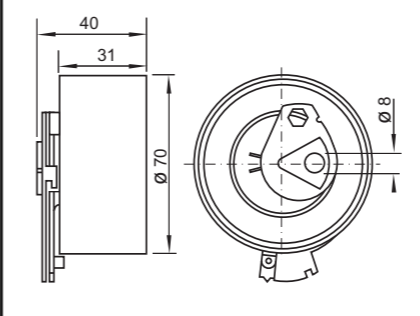

12551 **0829.A0**

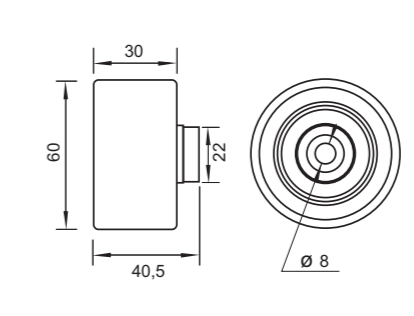

12594 **0830.62**

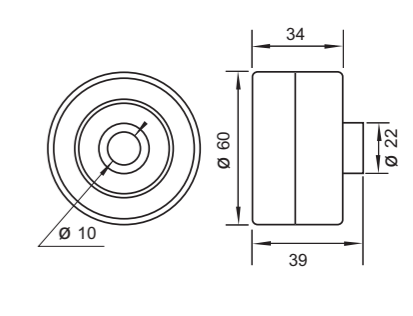

92102 **0830.42=9400830429**

MODELO MODEL	COMB./FUEL	MOTOR ENGINE	AÑO YEAR		CÓDIGO CODE		
			DESDE SINCE	HASTA TO	FIJO FIXED	MÓVIL MOBILE	NOTA NOTE

PEUGEOT 309

1.8 D	1769	D	161A (XUD7)	07/93	12/93	1900	1901	
1.9 D	1905	D	XUD9	06/86	06/93	1814	1813	
1.9 D	1905	D	XUD9	07/93	12/93	1900	1901	

PEUGEOT 405

1.4	1360	N	KDX (TU3MC)	01/87	10/95		1811	
1.6	1580	N	XU5	07/87	01/92		1812	
1.6	1580	N	XU5	02/92	10/95		1811	
1.8	1750	N	LFZ (XU7JP)	08/92	10/95		1811	
1.9	1905	N	XU9	07/87	01/92		1812	
1.9	1905	N	XU9	02/92	12/92		1811	
2.0	1998	N	RFX (XU10J2C)	08/92	10/95		1811	
2.0i 16v	1998	N	RFT	08/92	10/95	1862	1869	
2.0i 16v	1998	N	RFT	08/92	10/95	1862	12276	
2.0 MI 16v	1998	N	RFY (XU10J4/Z)	08/92	10/95	1862	12276	
2.0 Turbo 16v	1998	B	RGZ (XU10J4TE/Z)	08/92	10/95		1811 12276	
1.8TD	1769	D	XUD7	03/88	12/92	1814	1813	
1.9 D	1905	D	XUD9	03/88	06/93	1814	1813	
1.9 D	1905	D	XUD9	07/93	10/95	1900	1901	
1.9TD	1905	D	XUD9	03/88	06/93	1814	1813	
1.9TD	1905	D	XUD9	07/93	10/95	1900	1901	

PEUGEOT 406

1.6i	1580	N	BFZ (XU5JP)	11/95			1811	
1.8i	1761	N	LFZ (XU7JB)	05/97			1811	
1.8i 6v	1761	N	LFY (XU7JP4)	11/95		1862	1943	
2.0		N	LFY (XU7JP4)	11/95		1862	1943	
2.0 16v	1997	N	RFR	01/99		1122	1121	

CÓDIGO CODE	EM	CÓDIGO ORIGINAL ORIGINAL CODE	CÓDIGO CODE	EM	CÓDIGO ORIGINAL ORIGINAL CODE	CÓDIGO CODE	EM	CÓDIGO ORIGINAL ORIGINAL CODE
1121		0829.49	1122		0830.20	1811		0829.19=9605266280
1812		0829.12	1813		0829.11=0829.21	1814		0830.02=93501405
1862		9609908980=0830.11=0830.14	1869		0829.20=0829.42	1900		0830.13=9615923380
1901		0829.47=9617188680	1943		0829.32	12276		0829.31=0829.46=9613700180

MODELO MODEL	COMB./FUEL	MOTOR ENGINE	AÑO YEAR		CÓDIGO CODE EM euromotor®		
			DESDE SINCE	HASTA TO	FIJO FIXED	MÓVIL MOBILE	NOTA NOTE

PEUGEOT 406

3.0 24v	2946	N	XFZ	12/99		1170 1170 1171	12465
1.9 D	1905	D	XUD9	01/96		1900	1901
1.9 TD	1905	D	XUD9	01/96		1900	1901
2.0 HDI	1997	D	RHZ (DW10ATED)	02/99		12094	12093
2.1 TD	2088	D	P8C (XUD11BTE)	01/96		1862	1871
2.2 HDI	2179	D	DW12TED4	02/00		12094	12093

PEUGEOT 407

1.8 16v	1749	N		03/04		92102	12334
2.2 16v	2230	N		03/04		92102	12334
3.0i 24v	2946	N	AFX (ES9J45)	03/04		1170 1170 1171	12465
1.6 16v HDi	1560	D	DV6TED4	05/04		12377	12498
2.0 16v HDi	1997	D	DW10BTED4	05/04		12507	12522

PEUGEOT 505

2.0		N		05/79	12/93		1817
2.2		N		05/79	12/93		1817

PEUGEOT 605

2.0i	1998	N	RFZ (XU10J2)	06/89	06/93	1862	12156
2.0i	1998	N	RFZ (XU10J2)	07/93	10/99		1811

CÓDIGO EM CÓDIGO ORIGINAL ORIGINAL CODE

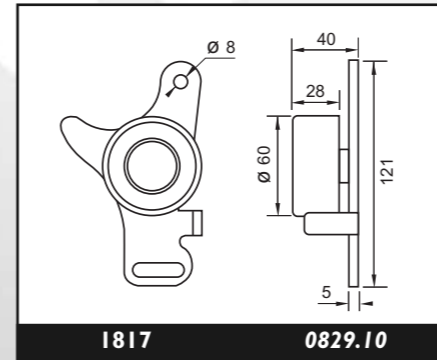

CÓDIGO EM CÓDIGO ORIGINAL ORIGINAL CODE

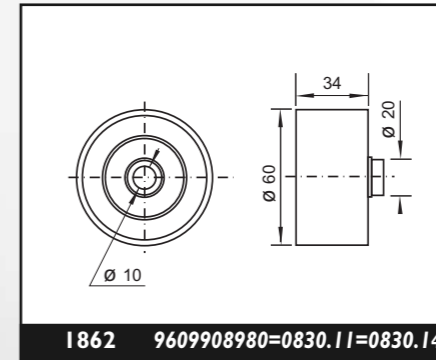

CÓDIGO EM CÓDIGO ORIGINAL ORIGINAL CODE

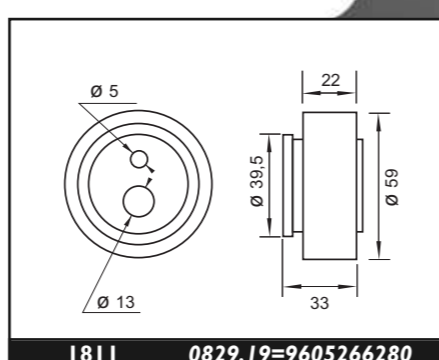
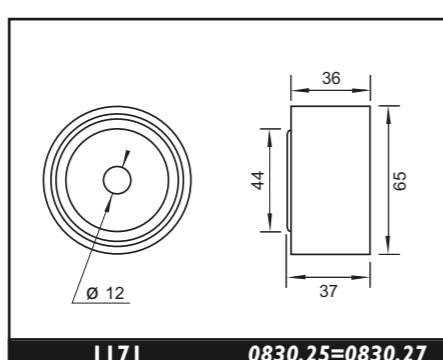
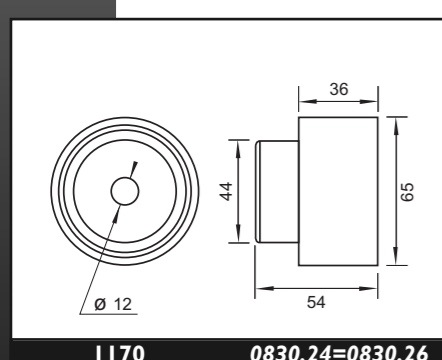
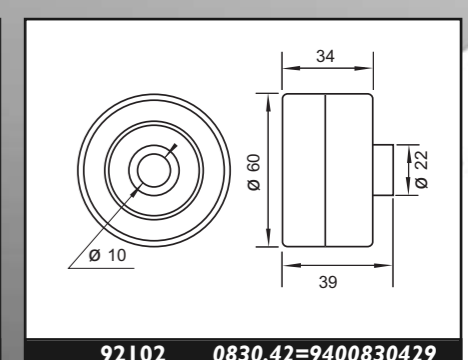
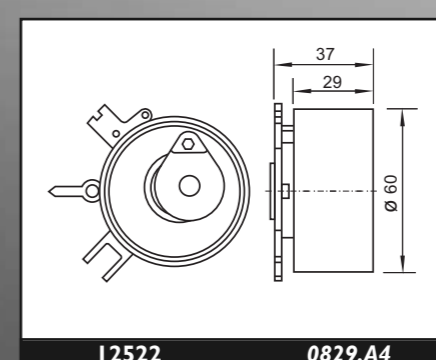
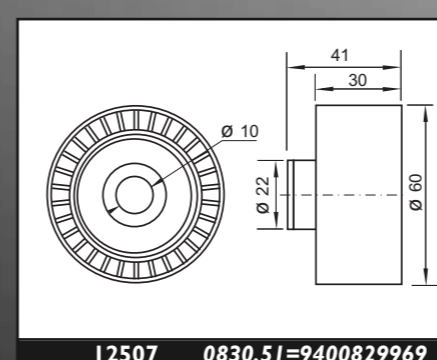
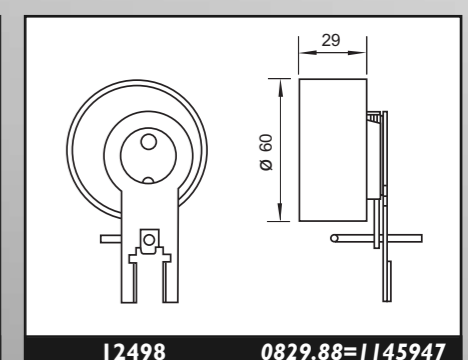
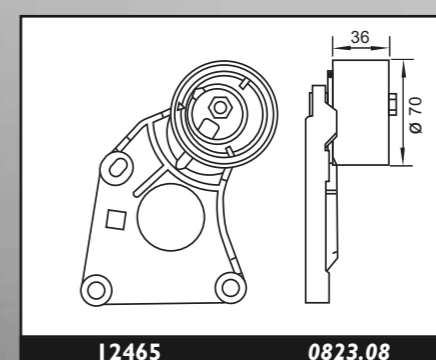
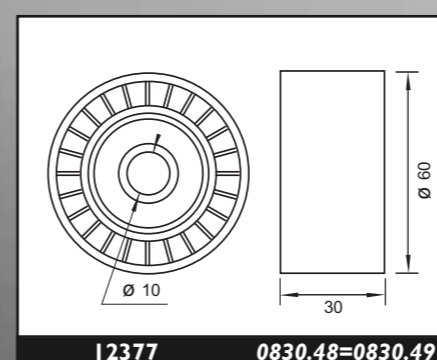
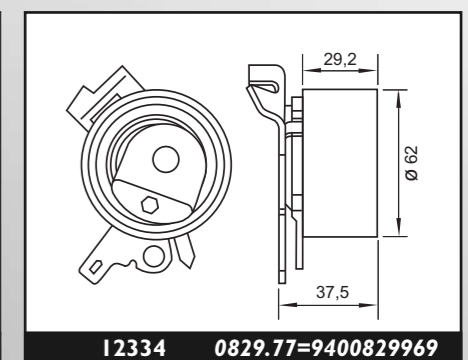
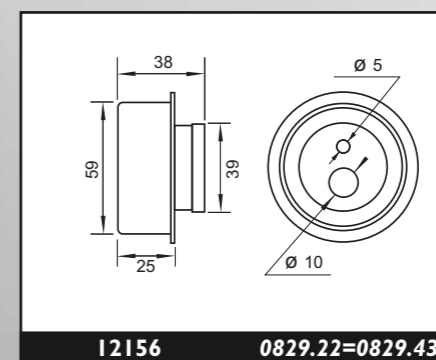
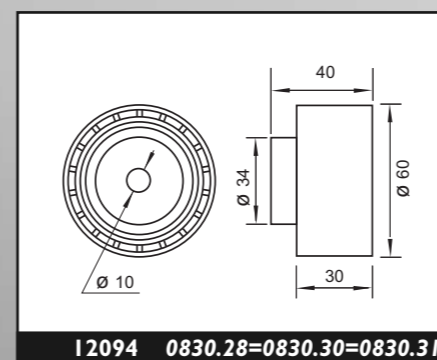
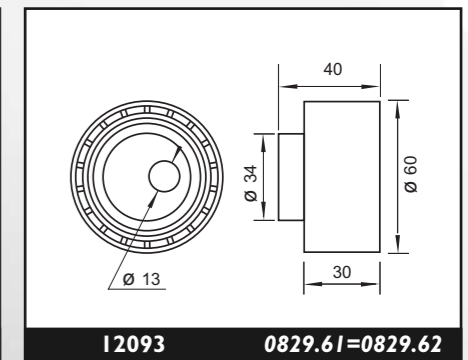
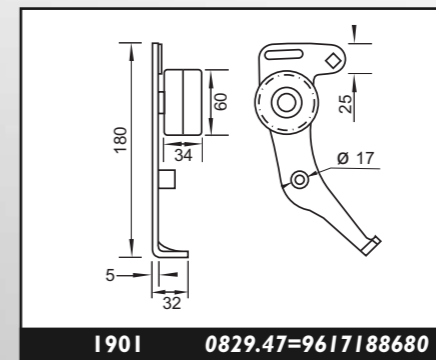
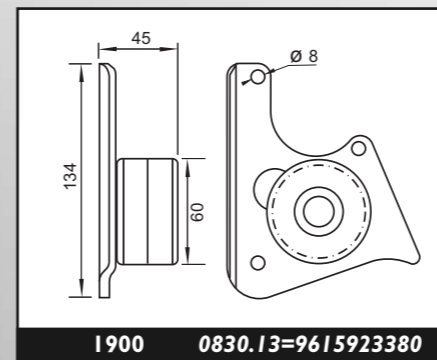
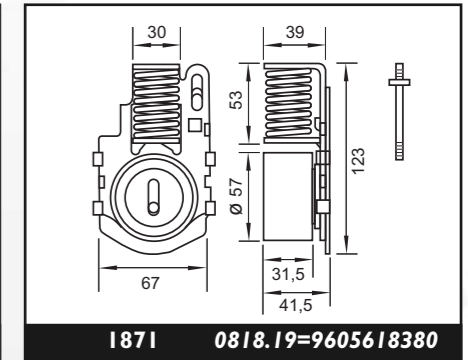

PEUGEOT

PEUGEOT

MODELO MODEL	AÑO YEAR	MOTOR ENGINE	CÓDIGO CODE			FIJO FIXED	MÓVIL MOBILE	NOTA NOTE
			DESDE SINCE	HASTA TO	EM euromotor®			

PEUGEOT 605

2.0i Turbo	1998	N	RGY/X (XU10J2TE/Z)	09/92			1811	
2.0 16v	1998	N	RFV (XU10J4R)	07/94		1862	1943	
3.0 V6 24v	2946	N	ES9J4 - ZPJ/Z	06/90		1170 1170 1171	1161	
2.1 D	2088	D	XUD11A/A/ATE/BTE	05/89		1862	1871	
2.1 TD	2088	D	XUD11A/A/ATE/BTE	05/89		1862	1871	
2.5 TD	2446	D	THY (DK5ATE)	05/94		1945	1944	

PEUGEOT 607

2.2 16v	2230	N	3FZ (EW12J4)	02/00		92102	12334	
3.0 V6 24v	2946	N	XFX (ES9J45)	02/00		1170 1170 1171	12465	
2.2 HDI	2179	D	DW12TED4	02/00		12094	12093	

Utilitarios

PEUGEOT 806

1.8	1750	N	LFW (XU7JP)	07/95			1811	
2.0 8v	1998	N	RFU (XU10J2)	06/94			1811	
2.0 8v	1998	N	RFU (XU10J2)	06/94			12276	
2.0 8v Turbo	1998	N	RGX (XU10J2TE)	06/94			1811	
2.0 16v	1998	N	XU10J4R	05/98	08/00	1862	1943	
2.0 16v	1998	N	RFN (EW10J4)	09/00		92102	12334	

CÓDIGO CODE	EM	CÓDIGO ORIGINAL ORIGINAL CODE	CÓDIGO CODE	EM	CÓDIGO ORIGINAL ORIGINAL CODE	CÓDIGO CODE	EM	CÓDIGO ORIGINAL ORIGINAL CODE
1171		0830.25=0830.27	1811		0829.19=9605266280	1862		9609908980=0830.11=0830.14
1871		0818.19=9605618380	1943		0829.32	1944		0818.20
1945		0830.12=96094102	12093		0829.61=0829.62	12094		0830.28=0830.30=0830.31
12276		0829.31=0829.46=9613700180	12334		0829.77=9400829969	12465		0823.08
92102		0830.42=9400830429						

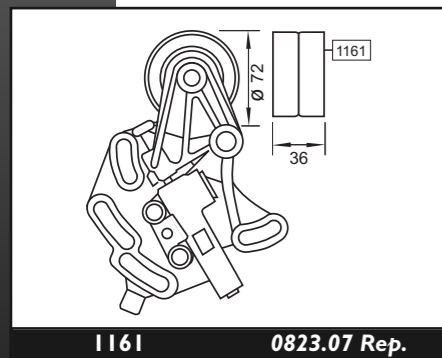

1161 0823.07 Rep.

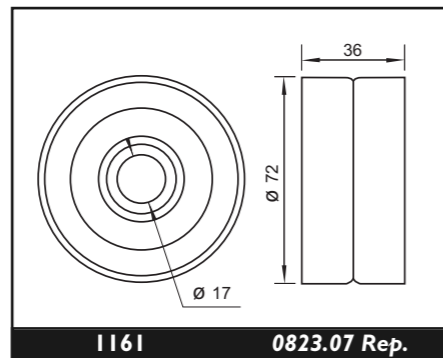

1161 0823.07 Rep.

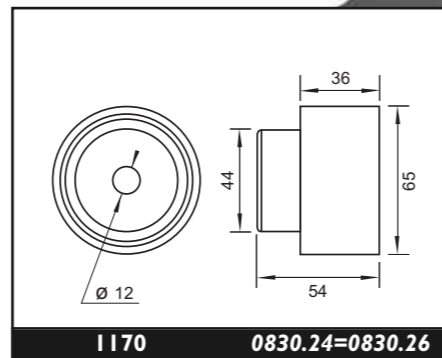

1170 0830.24=0830.26

MODELO MODEL	AÑO YEAR	MOTOR ENGINE	CÓDIGO CODE			FIJO FIXED	MÓVIL MOBILE	NOTA NOTE
			DESDE SINCE	HASTA TO	EM euromotor®			

PEUGEOT 806

1.9TD	1905	D	DHX - DHY (XUD9)	02/95		1900	1901	
2.0 HDI	1997	D	DW10-DW10ATED	08/99		12094	12093	
2.1 TD	2088	D	P8C (XUDI1BTE)	05/96	07/99	1862	1871	

PEUGEOT 807

2.0 16v	1997	N	RFN (EW10J4)	06/02		92102	12334	
2.2 16v	2230	N	3FZ (EW12J4)	06/02		92102	12334	
3.0V6 24v	2946	N	XFX (ES9J45)	02/00		1170 1170 1171	12465	
2.0 16v HDi	1997	D	RHS (DW10RTED4)	02/99		12094	12093	
2.2 16v HDi	2179	D	4HX (DW12TED4)	02/00		12094	12093	

PEUGEOT RANCH

1.1i	1124	N	HDZ (TU1M)	06/96			1811	
1.4i	1360	N	KFX (TU3JP)	06/96			1811	
1.6 16v	1587	N	NFV	10/00		1122	12451	
1.8i	1761	N	LFX (XU7JB)	05/97			1811	
1.8 D	1769	D	161 A (XUD7)	07/98		1900	1901	
1.9 D	1868	D	WJC (DW8)	07/98		12094	12093	
1.9 D	1905	D	DJY (XUD9A)	06/96		1900	1901	
2.0 HDI	1997	D	DW10	02/00		12094	12093	

PEUGEOT BOXER

2.0i	1998	N	RFW (XU10J2)	03/94			1943	
1.9 D	1905	D	XUD9	03/94		1900	1901	
1.9 TD	1905	D	XUD9	03/94		1900	1901	
2.0 HDI	1997	D	RHV (DW10)	04/02		12094	12093	
2.2 HDI	2179	D	DW12	04/02		12094	12093	

CÓDIGO EM CÓDIGO ORIGINAL ORIGINAL CODE

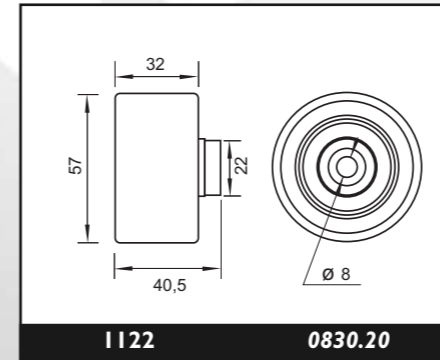

CÓDIGO EM CÓDIGO ORIGINAL ORIGINAL CODE

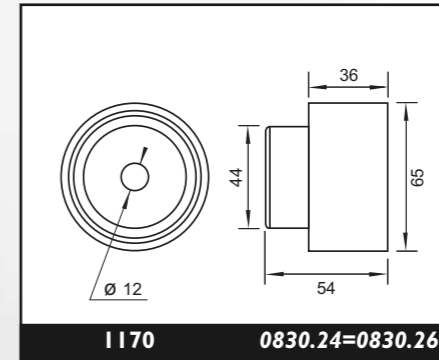

CÓDIGO EM CÓDIGO ORIGINAL ORIGINAL CODE

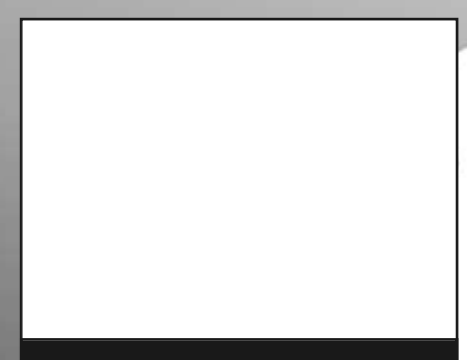
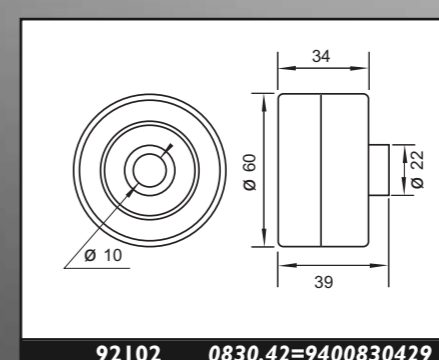
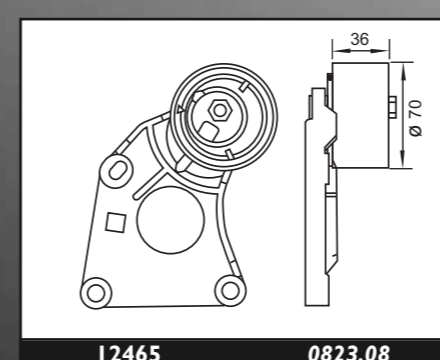
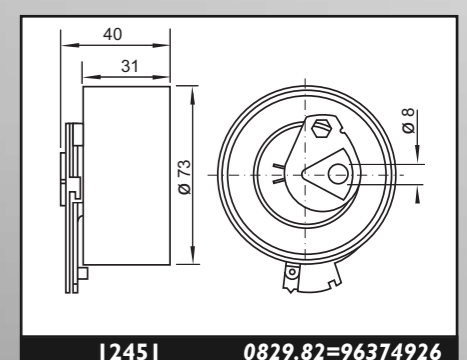
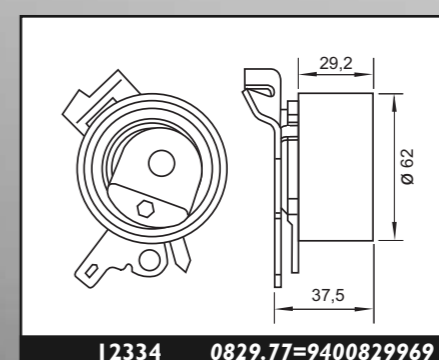
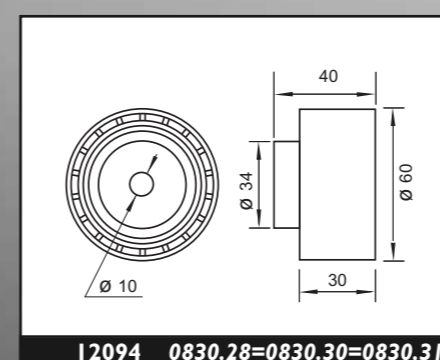
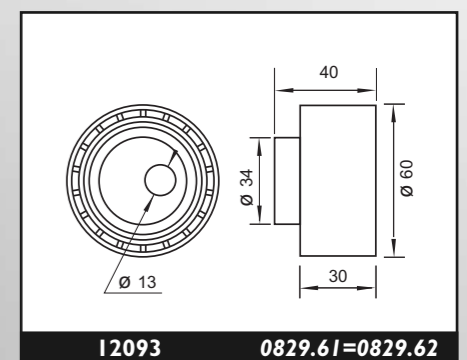
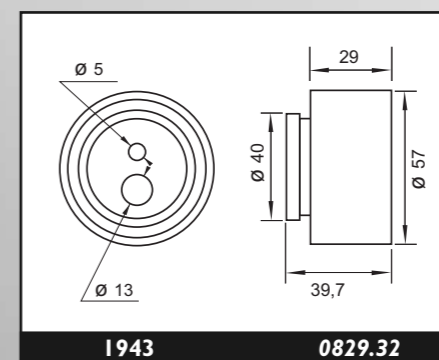
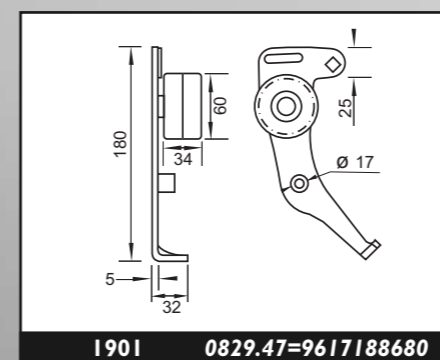
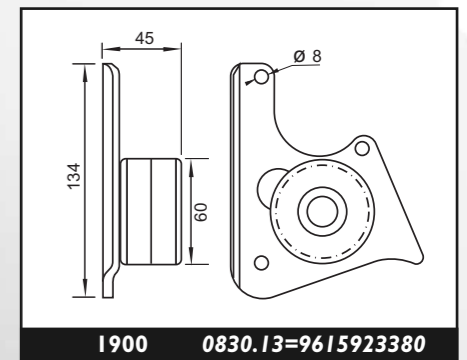
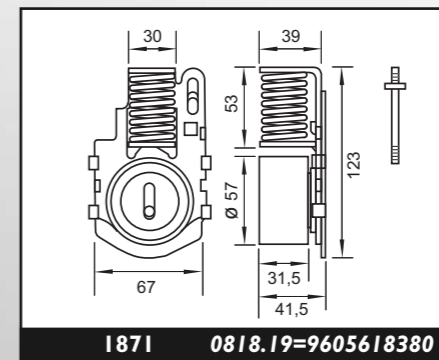
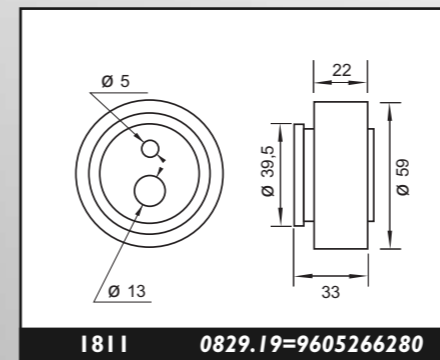
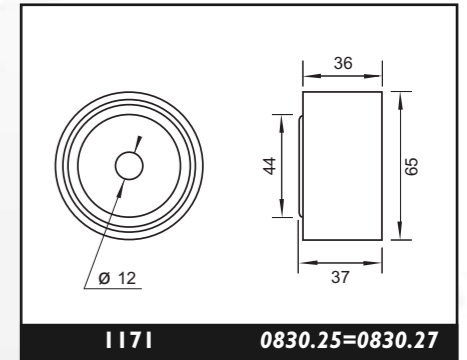

MODELO MODEL	COMB./FUEL	MOTOR ENGINE	AÑO YEAR		CÓDIGO CODE EM euromotor®		
			DESDE SINCE	HASTA TO	FIJO FIXED	MÓVIL MOBILE	NOTA NOTE

PEUGEOT BOXER

2.5 D	2446	D	T9A (DJ5)	07/94		1945	1944	
2.5 TD	2446	D	T8A (DJ5T)	07/94		1945	1944	
2.5 TDI	2446	D	THX (DJ5TED)	01/97		12272	12243	
2.8 HDI	2800	D	HDI-DCR	09/00	03/02	1816	1821	
2.8 HDI	2800	D	8140.63	04/02		1816	1816	

PEUGEOT EXPERT

1.6	1581	N	220A2000	02/96		1832		
1.8	1761	N	LFW	01/93			1811	
1.9 D	1867	D	DW8	04/98		1119 ó 12094	1118 ó 12093	
1.9 D	1905	D	XUD9	02/96		1900	1901	
1.9 TD	1905	D	XUD9	02/96		1900	1901	
2.0 HDI	1997	D	DW10	07/00		12094	12093	

PEUGEOT J5

2.0	1998	N	XU10	07/81	02/94	12276	12156	
1.9 D	1905	D	XUD9	07/81	06/93	1814	1813	
1.9 D	1905	D	XUD9	07/93	02/94	1900	1901	
1.9 TD	1905	D	XUD9	07/81	06/93	1814	1813	
1.9 TD	1905	D	XUD9	07/93	02/94	1900	1901	
1.9 TD	1930	D	M705	04/92	02/94	12094	12093	

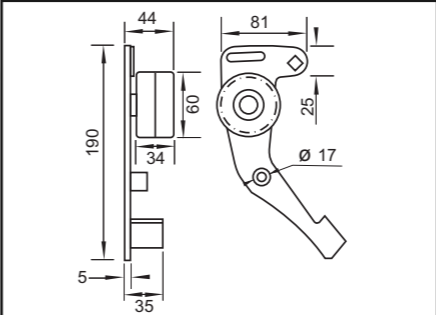
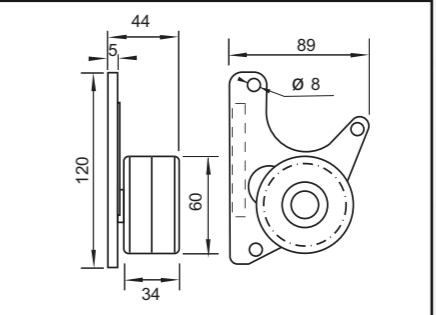
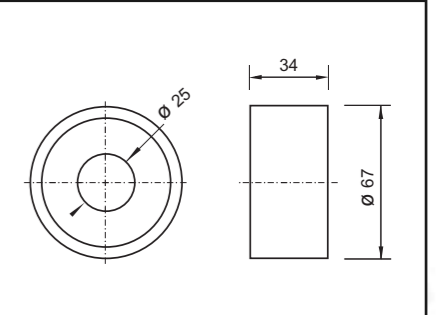
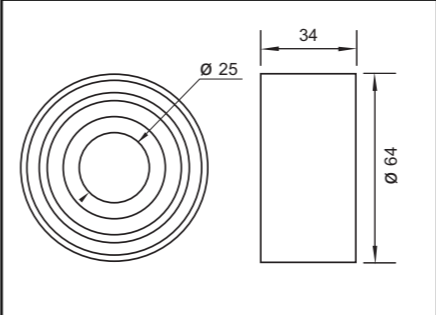
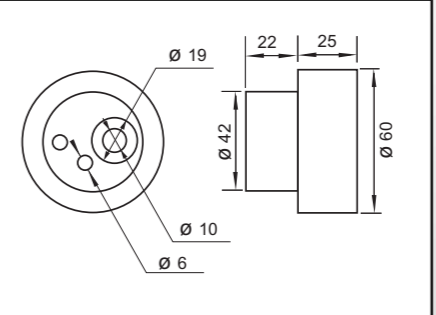
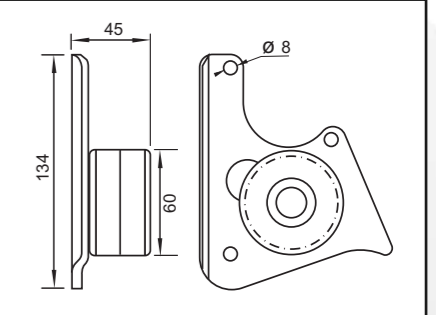
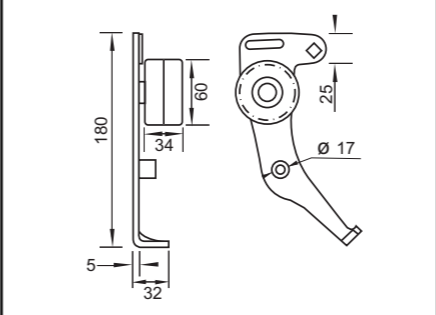
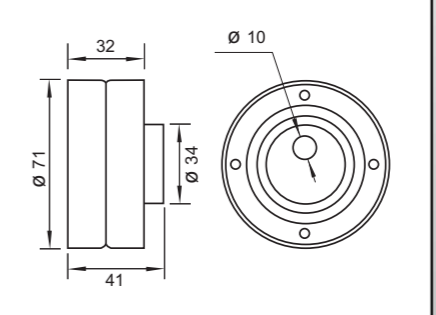
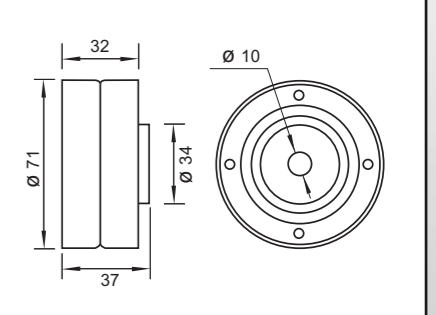
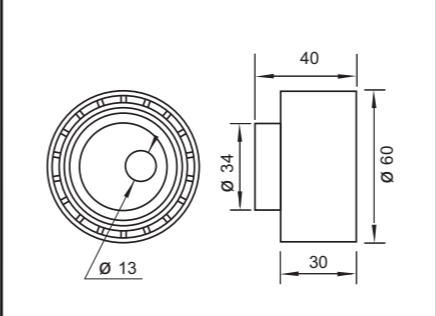
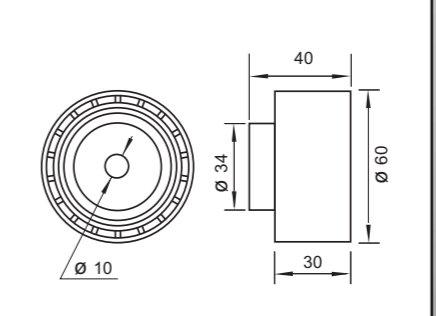
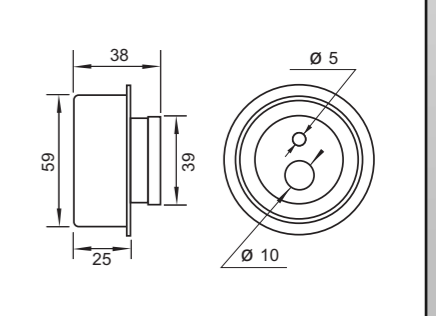
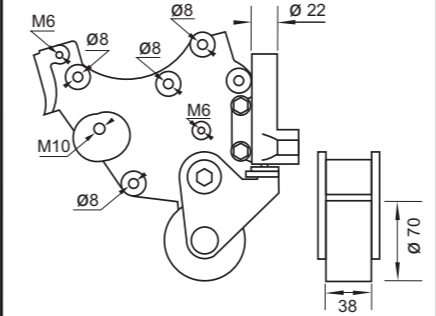
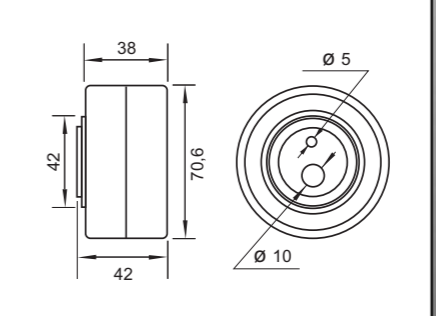
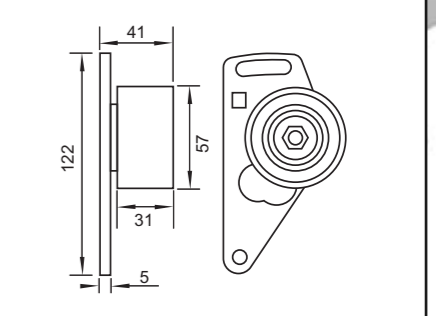
CÓDIGO CODE EM	CÓDIGO ORIGINAL ORIGINAL CODE	CÓDIGO CODE EM	CÓDIGO ORIGINAL ORIGINAL CODE	CÓDIGO CODE EM	CÓDIGO ORIGINAL ORIGINAL CODE
	0829.11=0829.21		0830.02=93501405		0830.40
	0830.32		7541718		0830.13=9615923380
	0829.47=9617188680		0818.20		0830.12=96094102
	0829.61=0829.62		0830.28=0830.30=0830.31		0829.22=0829.43
	0829.52=9627880580		0830.23		0829.31=0829.46=9613700180

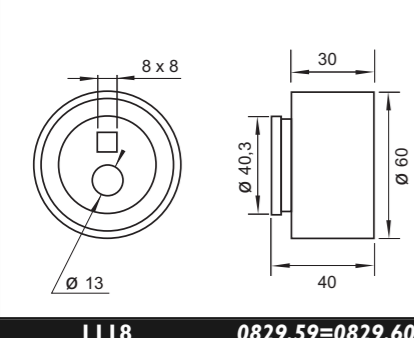

1118 0829.59=0829.60

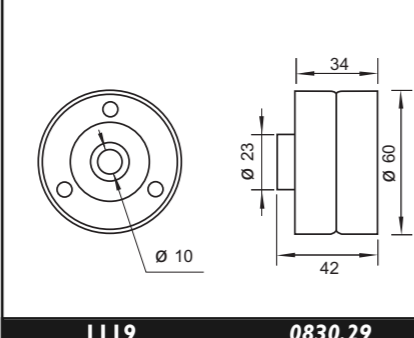

1119 0830.29

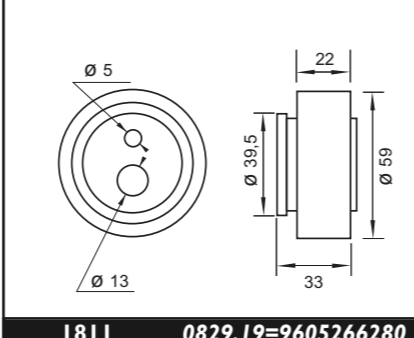

1811 0829.19=9605266280

MODELO MODEL	COMB./FUEL	MOTOR ENGINE	AÑO YEAR		CÓDIGO CODE EM euromotor®		
			DESDE SINCE	HASTA TO	FIJO FIXED	MÓVIL MOBILE	NOTA NOTE

PEUGEOT PARTNER

1.1i	1124	N	HDZ (TU1M)	06/96		1811	Hasta motor Up to engine 3762434	
1.1i	1124	N	HDZ (TU1M)	06/96		12376	Desde motor From engine 3762435	
1.4i	1360	N	KFX (TU3JP)	06/96		1811	Hasta motor Up to engine 3666766	
1.4i	1360	N	KFX (TU3JP)	06/96		12376	Desde motor From engine 3666767	
1.4 8v	1360	N	TU3JP	2007		1811		
1.4 16v	1360	N	ET3J4	2008		12545	12544	
1.6 16v	1587	N	NFU (TU5JP4)	07/01		1122	12451	Hasta motor Up to engine 1806404
1.6 16v	1587	N	NFU (TU5JP4)	07/01		12594	12551	Desde motor From engine 1806405
1.8i	1761	N	LFX (XU7JB)	05/97		1811		
1.8 D	1769	D	161 A (XUD7)	07/98		1900	1901	
1.9 D	1868	D	WJC (DW8)	07/98		12094	12093	
1.9 D	1905	D	DJY (XUD9A)	06/96		1900	1901	
2.0 HDI	1997	D	DW10	02/00		12094	12093	

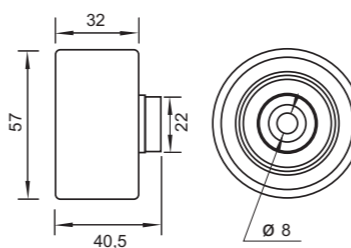
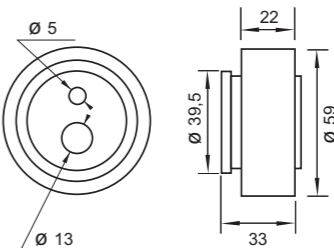
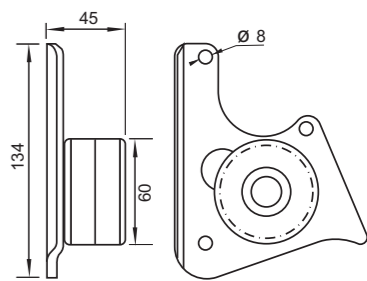
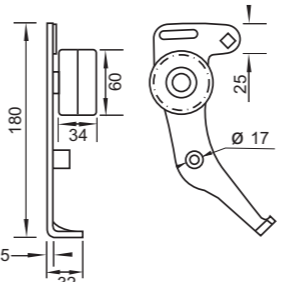
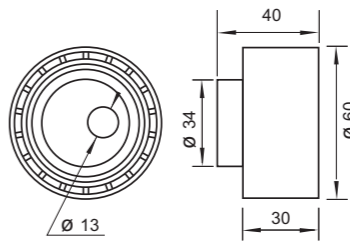
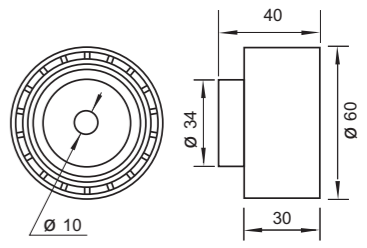
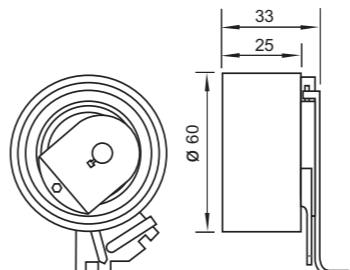
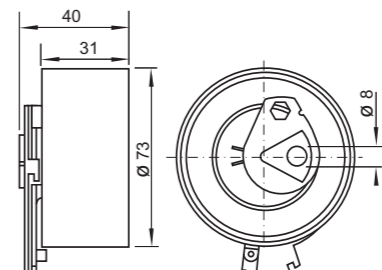
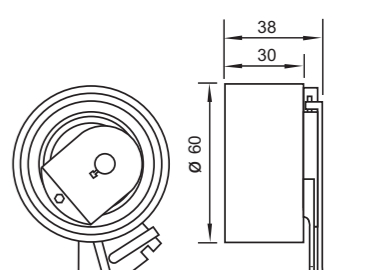
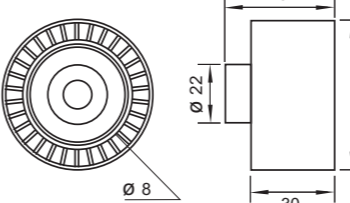
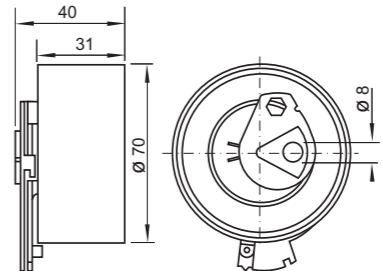
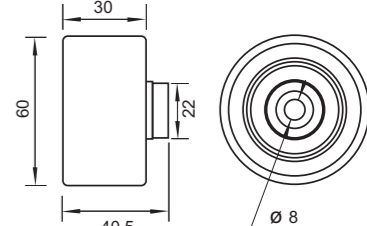
CÓDIGO CODE EM	CÓDIGO ORIGINAL ORIGINAL CODE	CÓDIGO CODE EM	CÓDIGO ORIGINAL ORIGINAL CODE	CÓDIGO CODE EM	CÓDIGO ORIGINAL ORIGINAL CODE
	0830.20		0829.19=9605266280		0830.13=9615923380
	0829.47=9617188680		0829.61=0829.62		0830.28=0830.30=0830.31
	0829.90=0829.91		0829.82=96374926		0829.C6
	0830.52		0829.A0		0830.62

EM euromotor®

VERSION PDF 2010



$\varnothing 18$

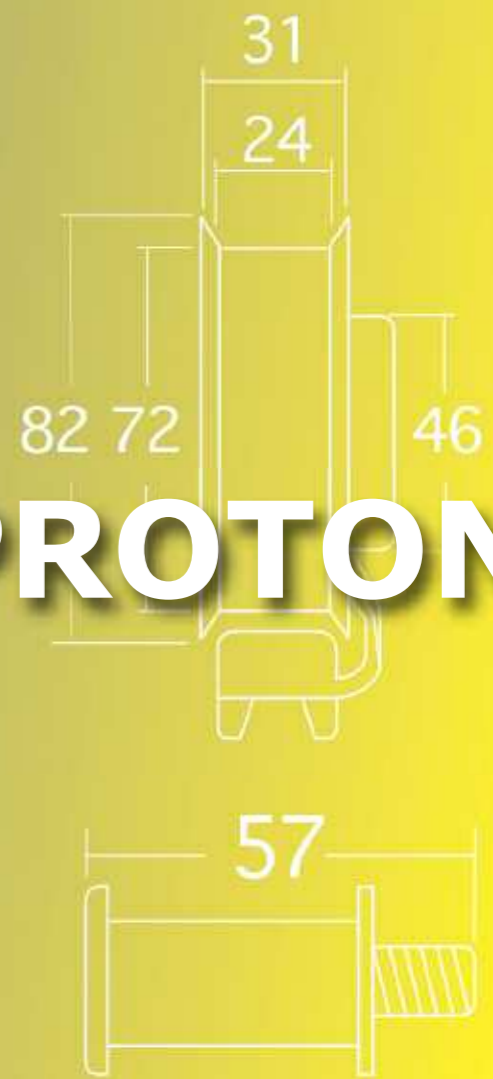

PROTON



EM euromotor®

VERSION PDF 2010



Ø18

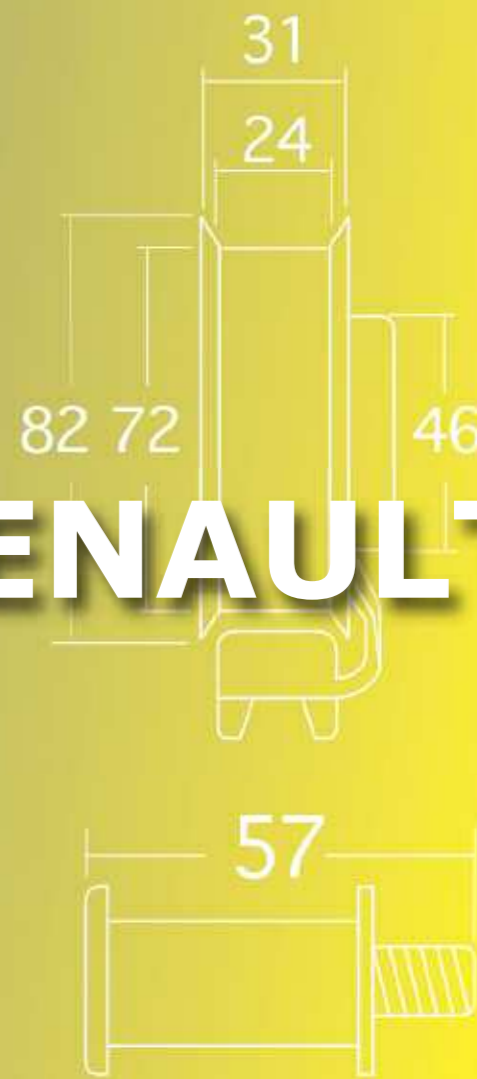

RENAULT



MODELO MODEL	COMB./FUEL	MOTOR ENGINE	AÑO YEAR		CÓDIGO CODE		
			DESDE SINCE	HASTA TO	FIJO FIXED	MÓVIL MOBILE	NOTA NOTE

RENAULT AVANTIME

2.0	1998	N	F3R	09/01		1854 1146	1173
2.0 16v	1998	N	F4R	09/01	05/02	12208 12424	12261
2.0 16v	1998	N	F4R	06/02		12246 12424	12261
3.0 24v	2946	N	L7X	09/01		1170 1170 1171	12465
1.9 DTi	1870	D	F9Q	09/01		12425 1153	12201
2.2 12v D	2188	D	G8T	09/01		1965	1112

RENAULT CLIO

1.2	1149	N	E5F - E7F D7F - D7D	03/91			1863
1.2 16V	1149	N	D4F - D4D	06/00			12299
1.4	1390	N	E6J	03/91			1863
1.4	1390	N	E7J	09/98			1145
1.4 16v	1390	N	K4J	10/99		12208	12177

CÓDIGO CODE	EM	CÓDIGO ORIGINAL ORIGINAL CODE	CÓDIGO CODE	EM	CÓDIGO ORIGINAL ORIGINAL CODE	CÓDIGO CODE	EM	CÓDIGO ORIGINAL ORIGINAL CODE
----------------	----	----------------------------------	----------------	----	----------------------------------	----------------	----	----------------------------------

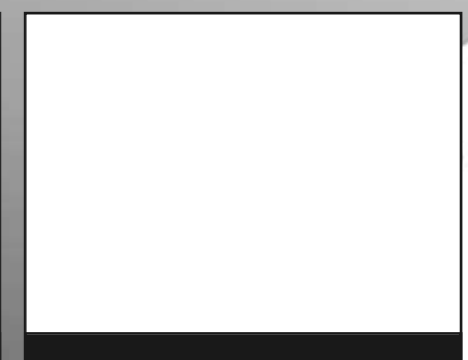
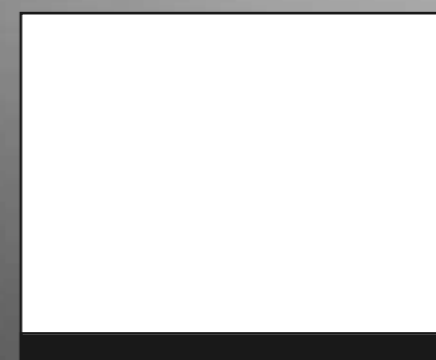
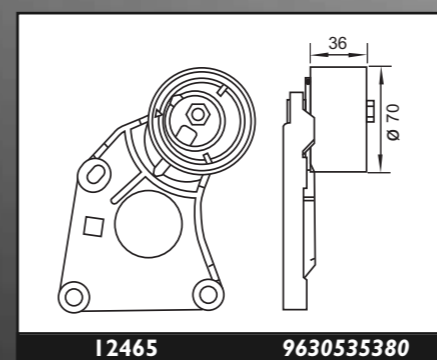
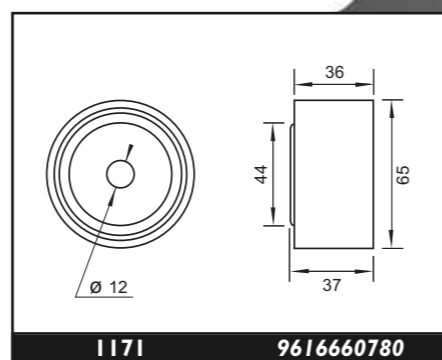
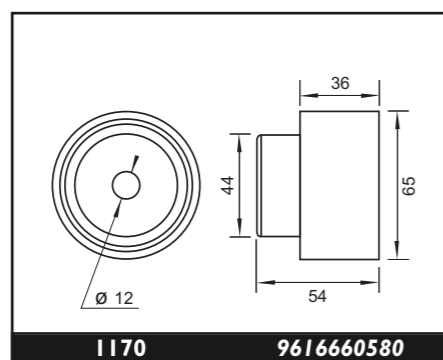
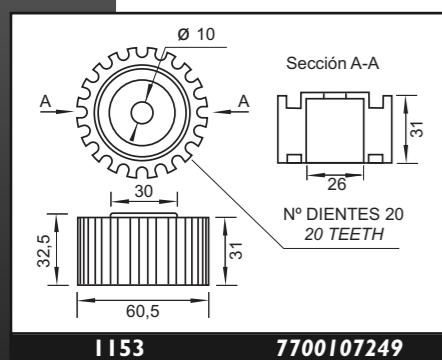
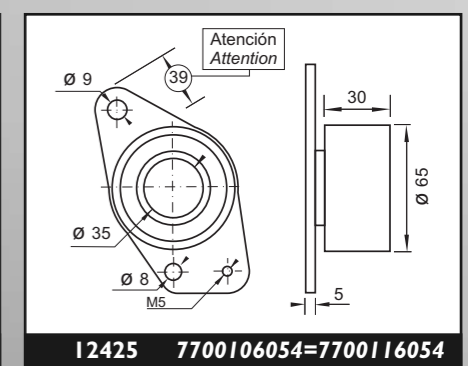
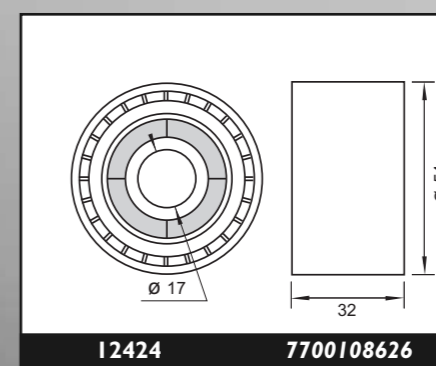
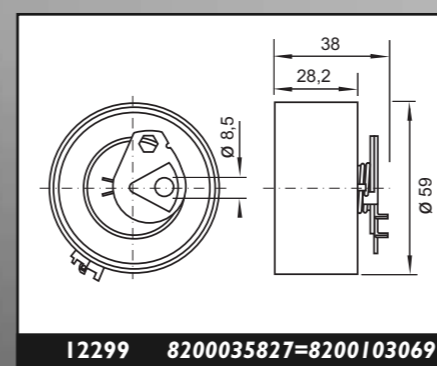
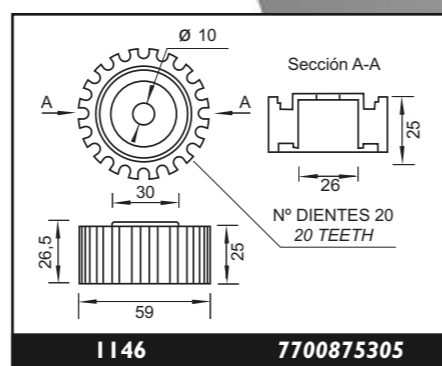
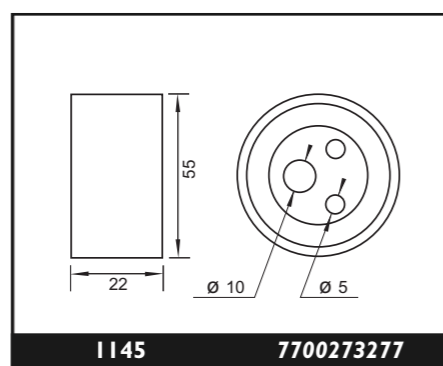
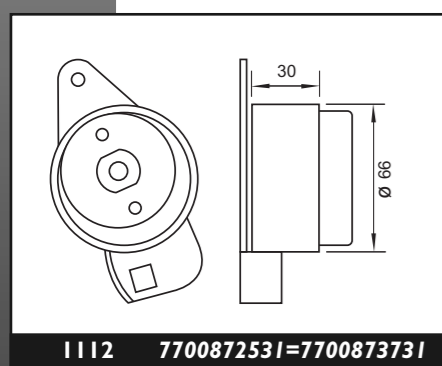
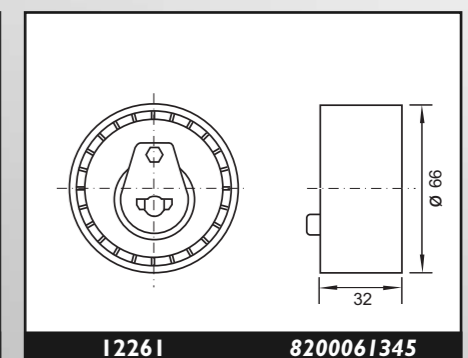
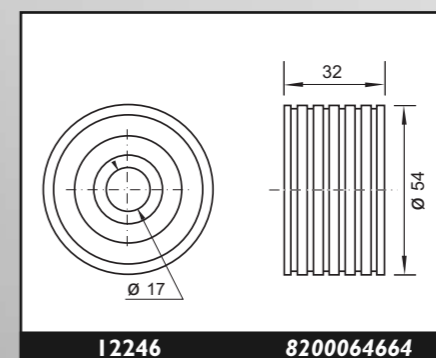
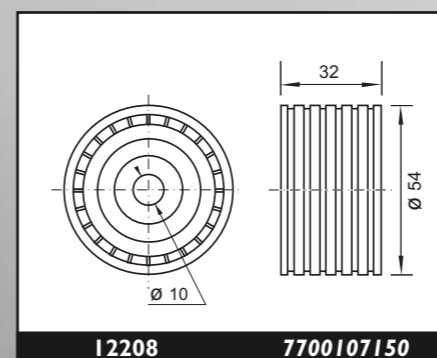
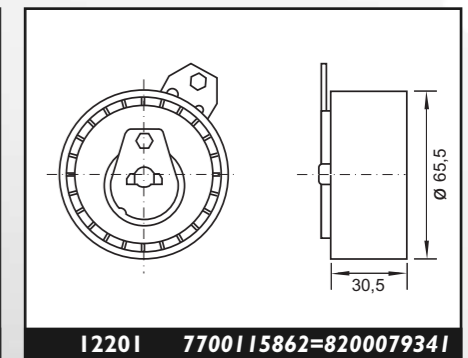
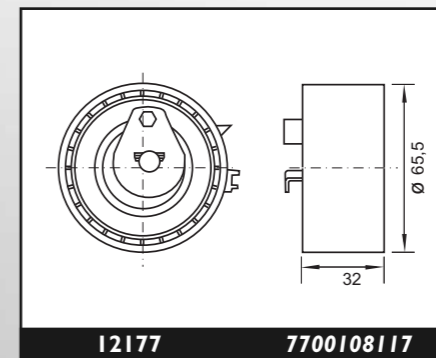
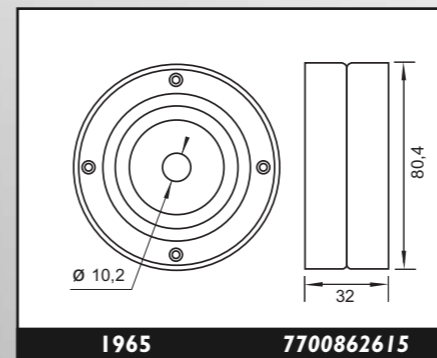
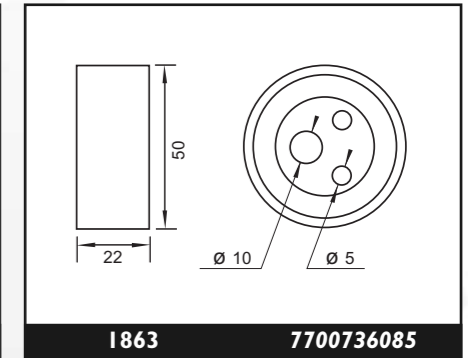
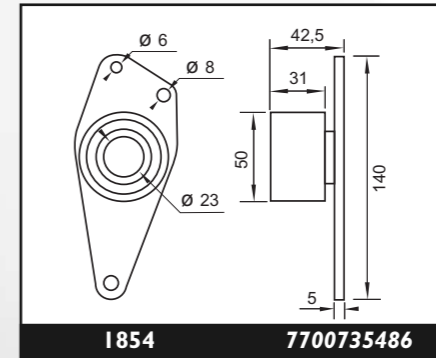
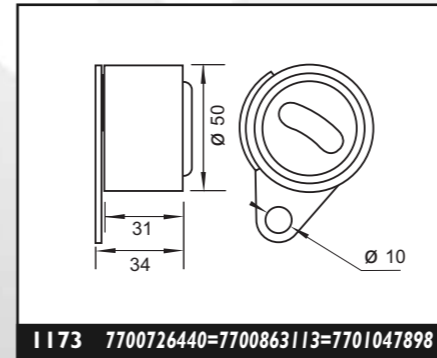

RENAULT

RENAULT

MODELO MODEL	COMB./ FUEL	MOTOR ENGINE	AÑO YEAR		CÓDIGO CODE EM euromotor®		
			DESDE SINCE	HASTA TO	FIJO FIXED	MÓVIL MOBILE	NOTA NOTE

RENAULT CLIO

1.6	1598	N	K7M	08/98			1145	
1.6	1598	N	K7J	08/98			1145	
1.6 16v	1598	N	K4M	09/98	05/05	12208	12177	
1.6 16v	1598	N	K4M	06/05		12208	12593	
1.7	1698	N	F2N	01/91	12/93	1854	1173	
1.8	1794	N	F3P	01/91	12/93	1854	1173	
1.8 16v	1794	N	F7P	09/90	06/94	1881	1880	
2.0		N	F7R	01/94	09/98	1881	1880	
2.0 16v	1998	N	F4R	02/00		12208 12424	12261	
3.0 24v		N	L7X	11/00		1170 1170 1171	12465	
1.5 DCi	1461	D	K9K	06/01			12298	65 cv - 82 cv 100 cv
1.9 D	1870	D	F8Q	09/90		1881 1153	1173	
1.9 DTi	1870	D	F9Q	02/00		12425 1153	12201	

REANULT ESPACE

2.0	1995	N	J6R - J7T	06/84	12/90		1817	
-----	------	---	-----------	-------	-------	--	------	--

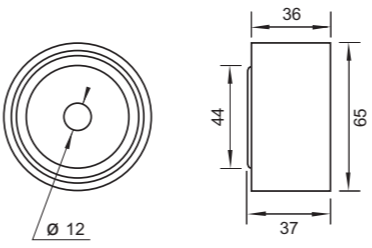
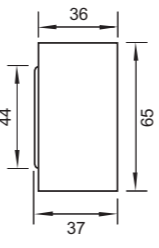
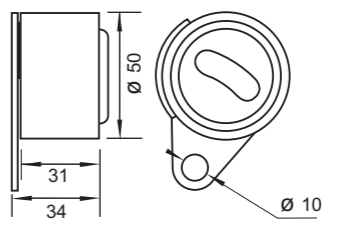
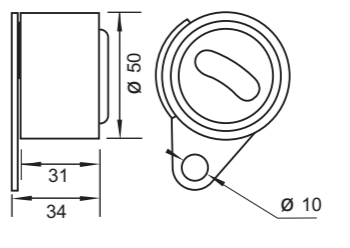
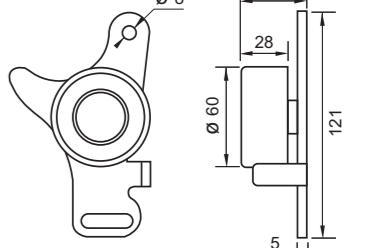
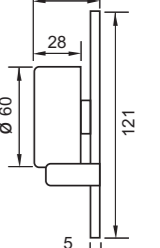
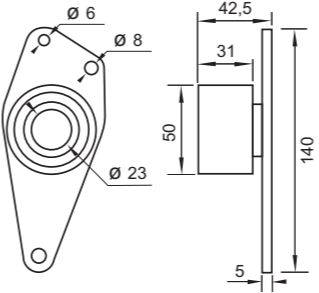
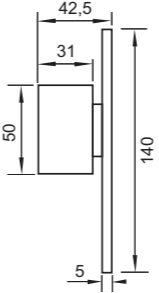
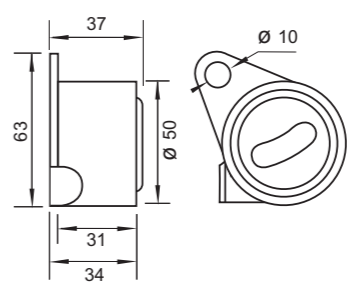
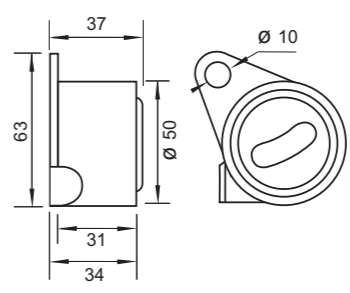
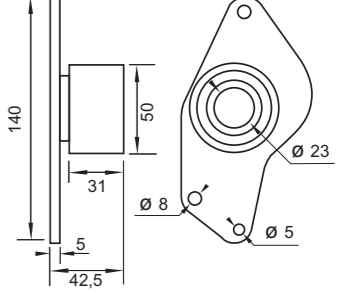
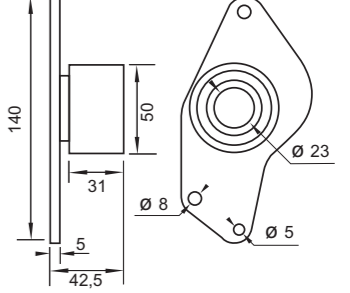
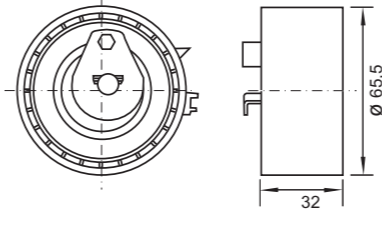
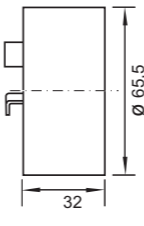
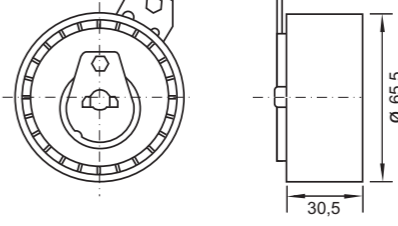
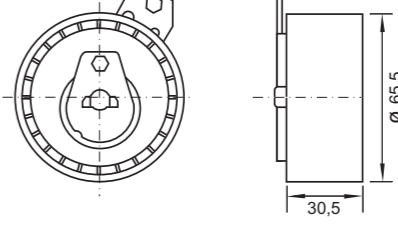
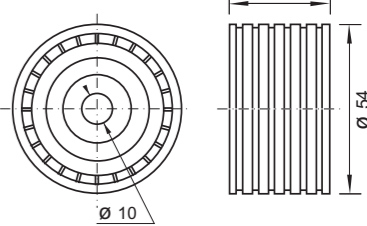
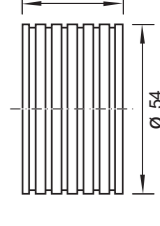
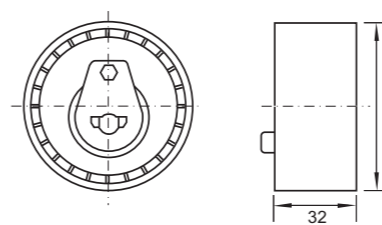
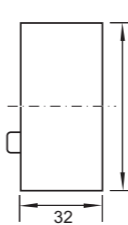
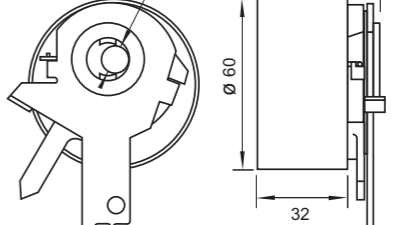
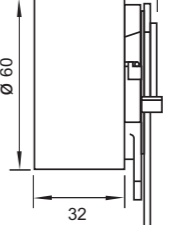
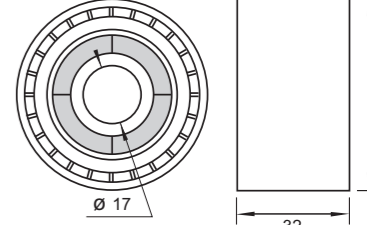
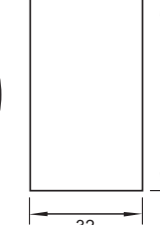
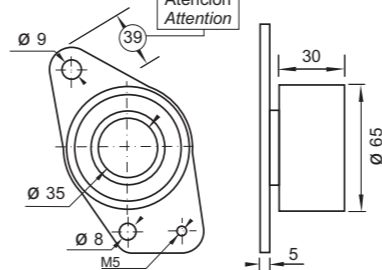
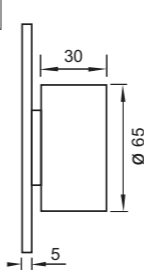
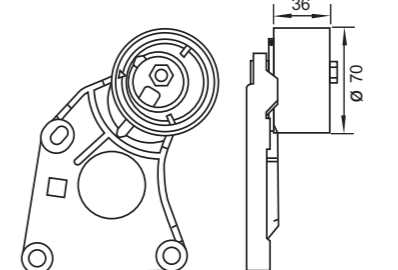
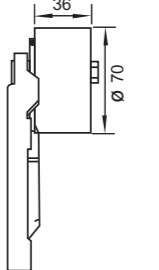
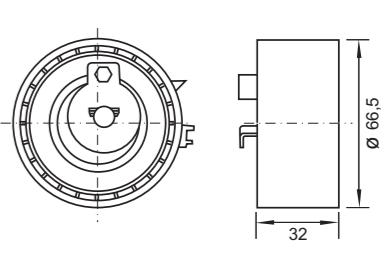
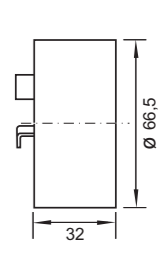
CÓDIGO CODE EM	CÓDIGO ORIGINAL ORIGINAL CODE	CÓDIGO CODE EM	CÓDIGO ORIGINAL ORIGINAL CODE	CÓDIGO CODE EM	CÓDIGO ORIGINAL ORIGINAL CODE
					
1171	9616660780	1173	7700726440=7700863113=7701047898	1817	7700692315
					
1854	7700735486	1880	7700736419	1881	7700266794=7700733489
					
12177	7700108117	12201	7700115862=8200079341	12208	7700107150
					
12261	8200061345	12298	8200102941	12424	7700108626
					
12425	7700106054=7700116054	12465	9630535380	12593	8200347761=8200191324

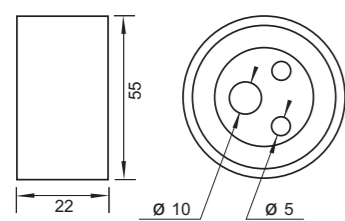

1145 7700273277

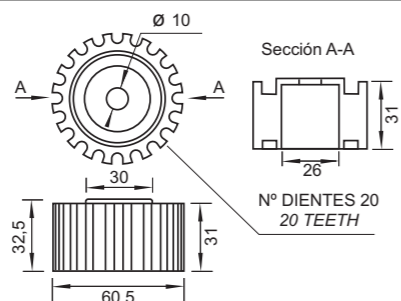

1153 7700107249

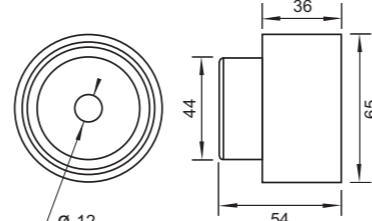

1170 9616660580

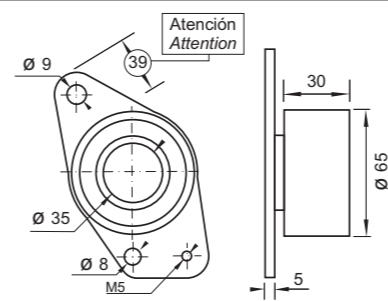

12425 7700106054=7700116054

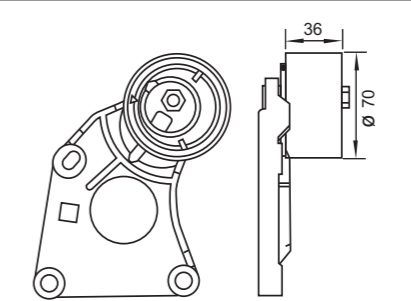

12465 9630535380

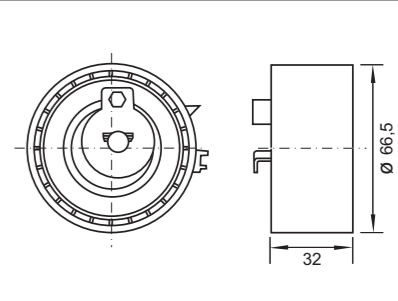

12593 8200347761=8200191324

MODELO MODEL	MOTOR ENGINE	AÑO YEAR		CÓDIGO CODE		
		DESDE SINCE	HASTA TO	FIJO FIXED	MÓVIL MOBILE	NOTA NOTE

REANULT ESPACE

2.0	1995	N	J7R - J7T	01/91	10/96		1882
2.0	1995	N	F3R	11/96		1854 1146	1173
2.0 16v	1995	N	F4R	10/98		12425 1146	12261
3.0V6	2958	N	LFX	12/99		1170 1170 1171	12465
1.9 DTi	1870	D	F9Q	02/99	10/00	1148 1153	1173
1.9 DTi	1870	D	F9Q	11/00		12425 1153	12201
2.1 D	2068	D	J8S	10/84	12/90	1857	1858
2.1 D	2068	D	J8S	10/84	12/90	1857	1913
2.1 D	2068	D	J8S	10/84		1857	1913
2.2 D	2188	D	G8T	11/95		1965	1112

REANULT FUEGO

2.0	1995	N	829	10/80	10/85		1817
2.2	2165	N	J7T	10/80	10/85		1817
2.1 TD	2068	D	J8S	08/82	10/85	1857	1913

CÓDIGO CODE	EM	CÓDIGO ORIGINAL ORIGINAL CODE	CÓDIGO CODE	EM	CÓDIGO ORIGINAL ORIGINAL CODE	CÓDIGO CODE	EM	CÓDIGO ORIGINAL ORIGINAL CODE
1153		7700107249	1170		9616660580	1171		9616660780
1173		7700726440=7700863113=7701047898	1817		7700692315	1854		7700735486
1857		7700721690	1858		7700722452	1882		7700745215
1913		7700852114=7700871169	1965		7700862615	12201		7700115862=8200079341
12261		8200061345	12425		7700106054=7700116054	12465		9630535380

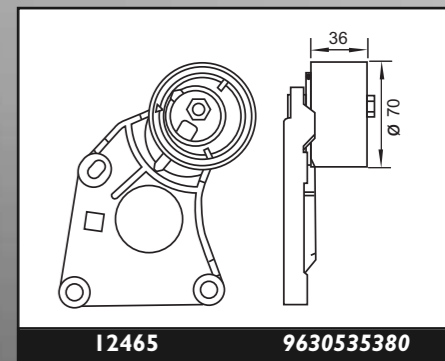
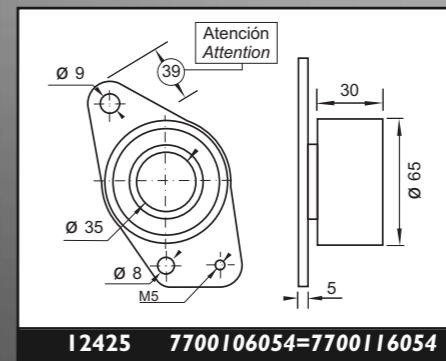
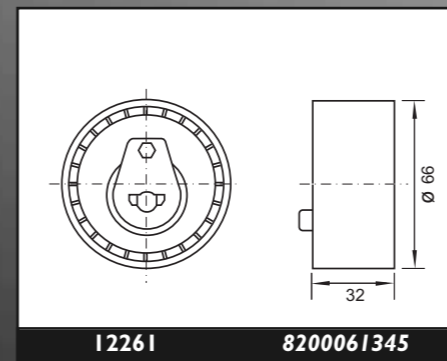
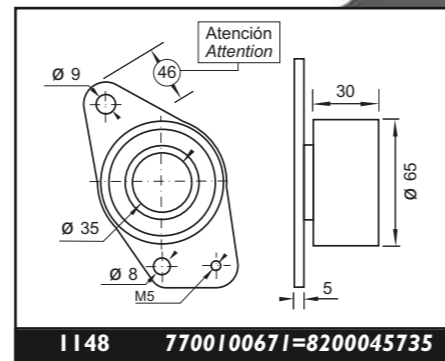
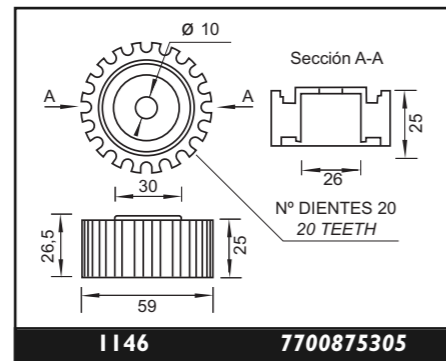
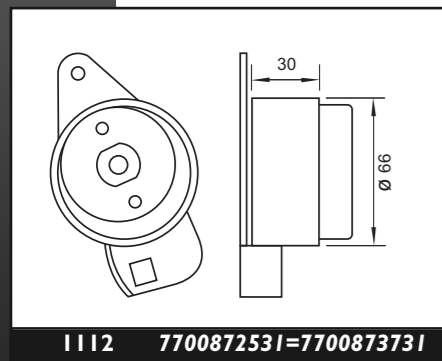

REANULT

REANULT

MODELO MODEL	MOTOR ENGINE	AÑO YEAR	CÓDIGO CODE	EM euromotor®	DESDE SINCE	HASTA TO	FIJO FIXED	MÓVIL MOBILE	NOTA NOTE
-----------------	-----------------	-------------	----------------	---------------	----------------	-------------	---------------	-----------------	--------------

RENAULT KANGOO

1.2	1149	N	D7F	03/98				1863	
1.2 16v	1149	N	D4F	06/00				12299	
1.4	1390	N	E7J	03/98				1145	
1.6	1598	N	K7J - K7M	03/98				1145	
1.6 16v	1598	N	K4M	06/01	05/05		12208	12177	
1.6 16v	1598	N	K4M	06/05			12208	12593	
1.5 DCi	1461	D	K9K	06/01				12298	
1.9 D	1870	D	F8Q	03/98			1881 1153	1173	
1.9 DTi	1870	D	F9Q -780- -782-	02/00			12425 1153	12201	
1.9 DCi	1870	D	F9Q - 790	02/00			12425 1153	1173	
1.9 DCi	1870	D	F9Q 790	10/01			12425 1153	12201	

RENAULT LAGUNA

1.6 16v	1598	N	K4M	11/97	03/01		12208	12177	
1.8	1794	N	F3P	11/93	03/01		1854	1173	
1.8 16v	1794	N	F4P 760	04/98	02/01		12208 12424	12261	
1.8 16v	1794	N	F4P - 770 - 771 - 772	03/01			12208	12261	
2.0	1998	N	F3R -611 - 768 -769	01/93			1854 1146	1173	
2.0	1998	N	F3R - 722 - 723 -728 - 729	01/93			1854	1173	
2.0 16v	1998	N	N7Q	06/95	11/97		12200	1930	

CÓDIGO CODE	EM	CÓDIGO ORIGINAL ORIGINAL CODE	CÓDIGO CODE	EM	CÓDIGO ORIGINAL ORIGINAL CODE	CÓDIGO CODE	EM	CÓDIGO ORIGINAL ORIGINAL CODE
1173	7700726440=7700863113=7701047898		1854	7700735486		1863	7700736085	
1881	7700863111=7700266794=7700733489		1930	7439135036		12177	7700108117	
12200	7439146376		12201	7700115862=8200079341		12208	7700107150	
12261	8200061345		12298	8200102941		12299	8200035827=8200103069	
12424	7700108626		12425	7700106054=7700116054		12593	8200347761=8200191324	

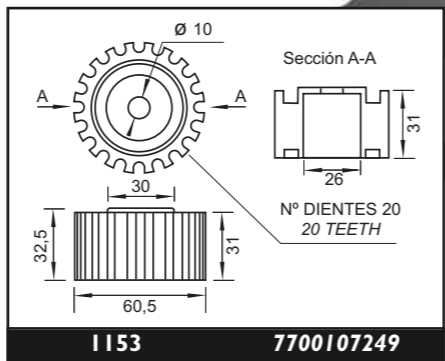
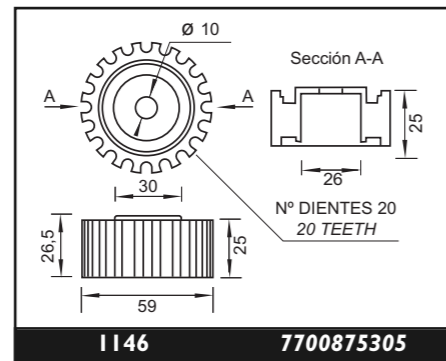
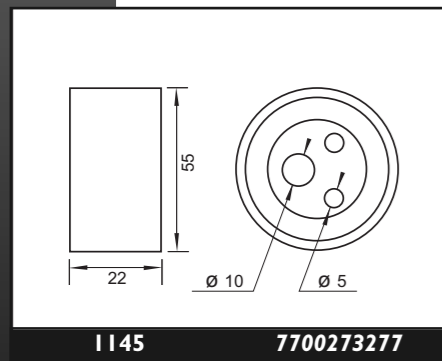

RENAULT

RENAULT

MODELO MODEL	COMB./FUEL	MOTOR ENGINE	AÑO YEAR		CÓDIGO CODE		
			DESDE SINCE	HASTA TO	FIJO FIXED	MÓVIL MOBILE	NOTA NOTE

RENAULT LAGUNA

2.0 16v	1998	N	N7Q - 704	12/97	02/01	12200	1137
2.0 16v	1998	N	F4R	03/01		12208 12424	12201
2.0 16v IDE	1998	N	F5R - 700 - 701	04/02		12246 12246	12261
3.0 24v	2958	N	LFX - L7X	03/97		1170 1170 1171	12465
1.9 DTi	1870	D	F9Q - 716	10/97	10/00	1148 1153	1173
1.9 DTi	1870	D	F9Q - 710	11/00	12/01	12425 1153	12201
2.2 D	2188	D	G8P - 706 - 790	11/93		12429	1112
2.2 D	2188	D	G8T - 752 - 792 - 794 - 760	11/95		1965	1112

RENAULT LOGAN

1.6 16v	1598	N	K4M-690	09/07		12208	12177
1.5 DCI	1460	D	K9K-700	04/08			12298

CÓDIGO CODE	EM	CÓDIGO ORIGINAL ORIGINAL CODE	CÓDIGO CODE	EM	CÓDIGO ORIGINAL ORIGINAL CODE	CÓDIGO CODE	EM	CÓDIGO ORIGINAL ORIGINAL CODE
1173		7700726440=7700863113=7701047898	1965		7700862615	12177		7700108117

12200		7439146376	12201		7700115862=8200079341	12208		7700107150
-------	--	------------	-------	--	-----------------------	-------	--	------------

12246		8200064664	12261		8200061345	12298		8200102941
-------	--	------------	-------	--	------------	-------	--	------------

1112 7700872531=7700873731

1137 7439440329

1148 7700100671=8200045735

12424 7700108626

12425 7700106054=7700116054

12429 7700857492

1153 7700107249

1170 9616660580

1171 9616660780

12465 9630535380

MODELO MODEL	MOTOR ENGINE	AÑO YEAR		CÓDIGO CODE		
		DESDE SINCE	HASTA TO	FIJO FIXED	MÓVIL MOBILE	NOTA NOTE

RENAULT MEGANE

1.4	1390	N	E7J (764)	01/99		1863
1.4	1390	N	E7J (626)	01/99		1145
1.4 16v	1390	N	K4J - 714-750-	03/99		12208 12177
1.6 i	1598	N	K7M - 704--720-	01/96	03/99	1145
1.6 16v	1598	N	K4M - 700--701-	03/99	05/05	12208 12177
1.6 16v	1598	N	K4M - 760-761-812	06/05		12208 12593
1.8 16v	1794	N	F4P - 720- -722-	01/01		12208 12424 12261
2.0 i	1998	N	F3R - 750- 791 -751-	01/96		1854 1173 1146
2.0 16v	1998	N	F7R - 710- -714-	01/95		1881 1880 1153
2.0 16v	1998	N	F5R - 740-	03/96		12208 12261 12424
1.5 DCi	1461	D	K9K - 722	11/02		12298
1.9 D	1870	D	F8Q - 620--784-	01/96		1854 1173
1.9 TD	1870	D	F8Q - 624- 786 - 788-	01/96		12606 1153 1173
1.9 DTi	1870	D	F9Q - 732- -733 - 734-	03/97	09/00	1148 1173 1153
1.9 DTi	1870	D	F9Q - 736- -744-	10/00		12425 12201 1153
1.9 DCi	1870	D	F9Q - 733-	02/01	10/02	1148 1173 1153

CÓDIGO CODE	EM	CÓDIGO ORIGINAL ORIGINAL CODE	CÓDIGO CODE	EM	CÓDIGO ORIGINAL ORIGINAL CODE	CÓDIGO CODE	EM	CÓDIGO ORIGINAL ORIGINAL CODE
1153		7700107249	1173		7700726440=7700863113=7701047898	1854		7700735486
1863		7700736085	1880		7700736419	1881		7700863111=7700266794=7700733489
12177		7700108117	12201		7700115862=8200079341	12208		7700107150
12261		8200061345	12298		8200102941	12424		7700108626
12425		7700106054=7700116054	12593		8200347761=8200191324	12606		7700863112

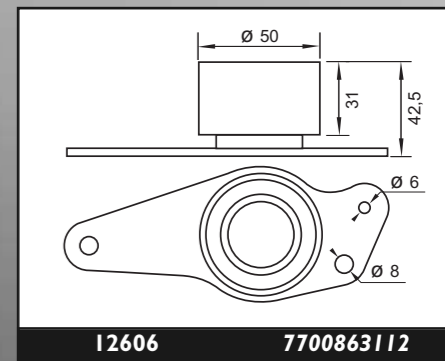
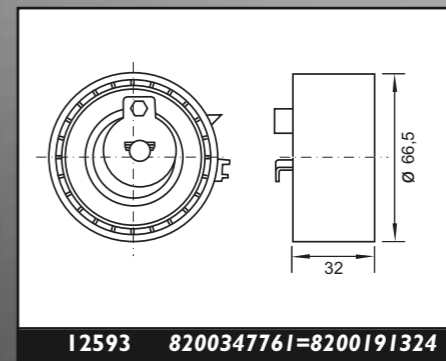
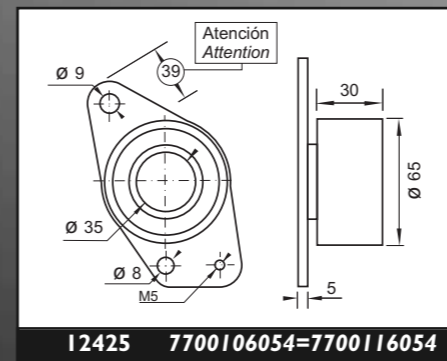
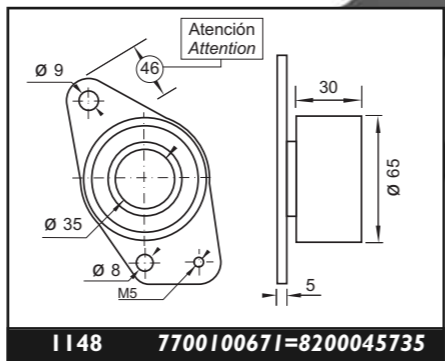
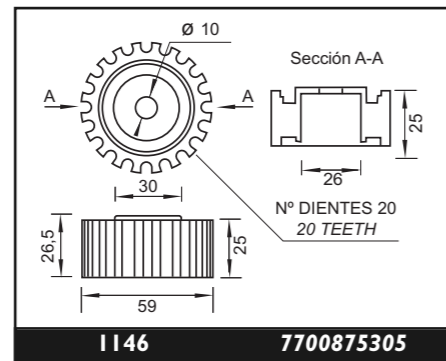
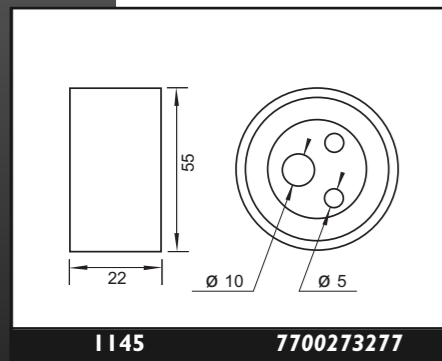

RENAULT

RENAULT

MODELO MODEL	MOTOR ENGINE	AÑO YEAR	CÓDIGO CODE	EM euromotor®	DESDE SINCE	HASTA TO	FIJO FIXED	MÓVIL MOBILE	NOTA NOTE
-----------------	-----------------	-------------	----------------	---------------	----------------	-------------	---------------	-----------------	--------------

RENAULT MEGANE COUPÉ - CABRIOLET

2.0 16v	1998	N	F5R-740	03/96			12208 12424	12261	
1.9 DTi	1870	D	F9Q	10/00			12425 1153	12201	

RENAULT COACH

2.0 16v	1998	N	F5R	03/96			12208 12424	12261	
---------	------	---	-----	-------	--	--	----------------	-------	--

RENAULT SCENIC

1.6	1598	N	K7M - 720	01/96	05/03			1145	
1.6 16v	1598	N	K4M - 704	03/99	10/05		12208	12177	
1.6 16v	1598	N	K4M-761-782-812	06/05			12208	12593	
1.8 16v	1794	N	F4P	01/01			12208 12424	12261	
2.0	1998	N	F3R - 750	01/96	05/93		1854 1146	1173	
2.0 16v	1998	N	F4R	01/99			12208 12424	12261	
1.5 DCi	1461	D	K9K - 722	10/03				12298	
1.9 TD	1870	D	F8Q - 620 - 624 - 784	01/96	05/03		12606	1173	
1.9DTi	1870	D	F8Q - 734 - 744 - 736	09/96	05/03		12425 1153	12201	
1.9 DCi RX4	1870	D	F9Q - 740	11/00	05/03		1148 1153	1173	

RENAULT SENDERO

1.6 16v	1598	N	K4M-740	03/08			12208	12177	
1.5 DCI	1461	D	K9K-700	03/08				12298	

RENAULT SYMBOL

1.6 16v	1598	N	K4M-740	02/09			12208	12177	
1.5 DCI	1461	D	K9K-700	02/09				12298	

CÓDIGO EM CÓDIGO ORIGINAL ORIGINAL CODE

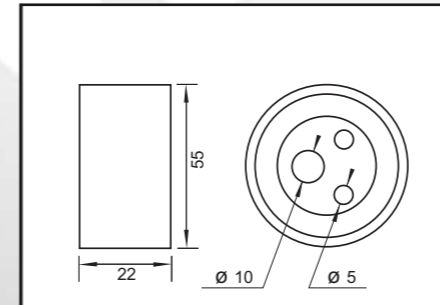

1145 7700273277

CÓDIGO EM CÓDIGO ORIGINAL ORIGINAL CODE

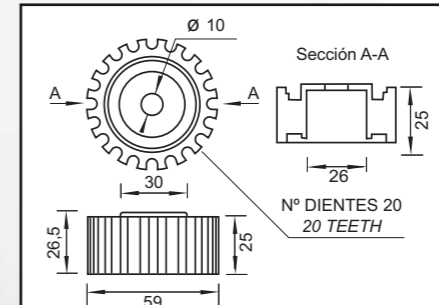

1146 7700875305

CÓDIGO EM CÓDIGO ORIGINAL ORIGINAL CODE

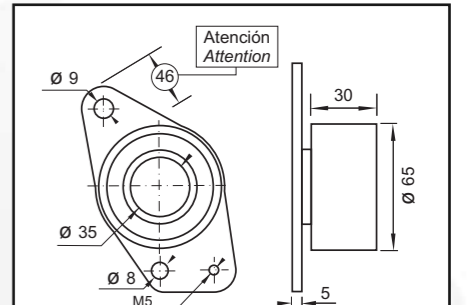

1148 7700100671=8200045735

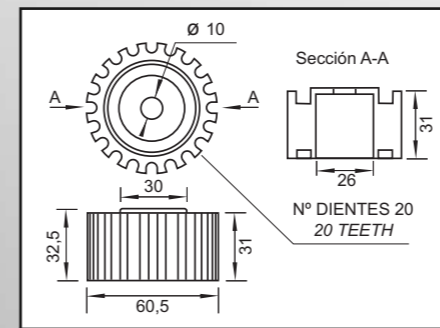

1153 7700107249

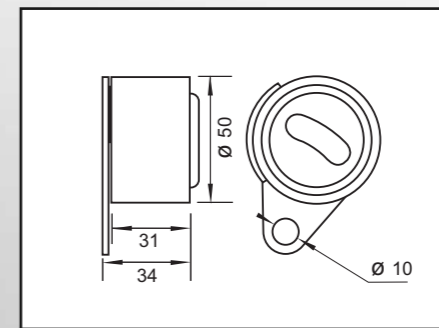

1173 7700726440=7700863113=7701047898

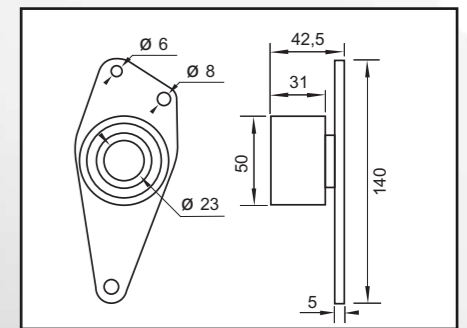

1854 7700735486

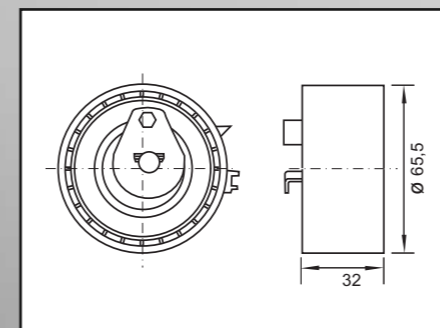

12177 7700108117

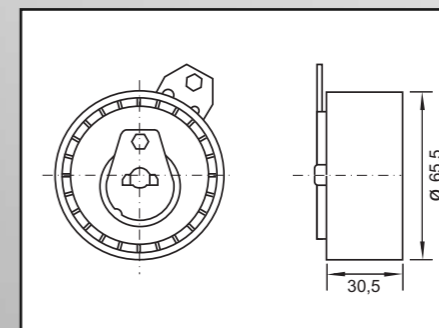

12201 7700115862=8200079341

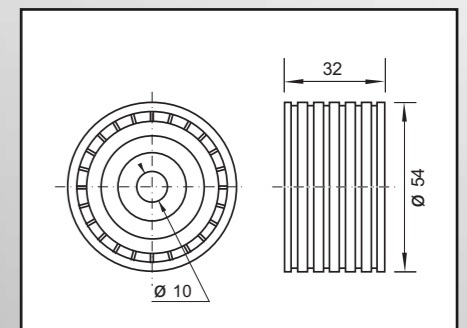

12208 7700107150

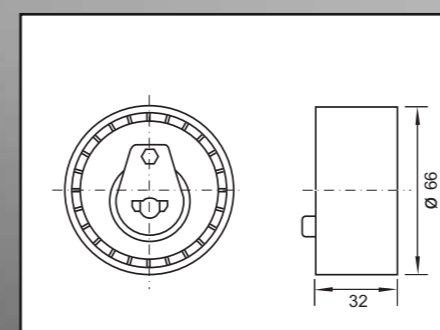

12261 8200061345

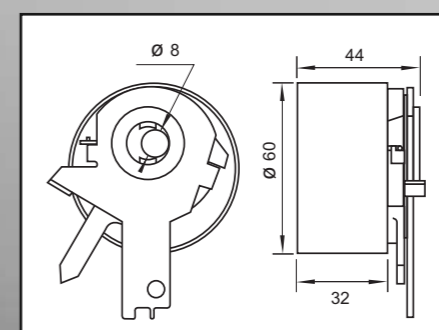

12298 8200102941

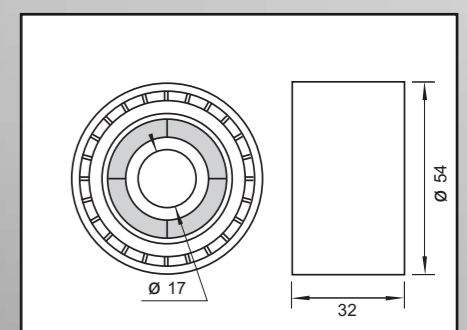

12424 7700108626

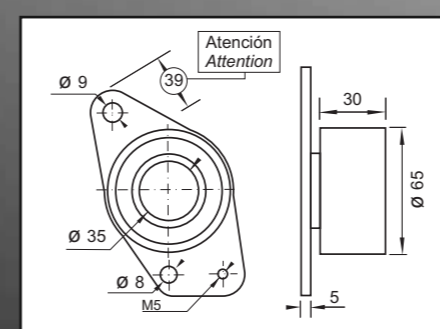

12425 7700106054=7700116054

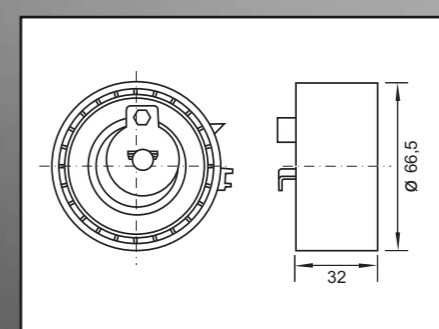

12593 8200347761=8200191324

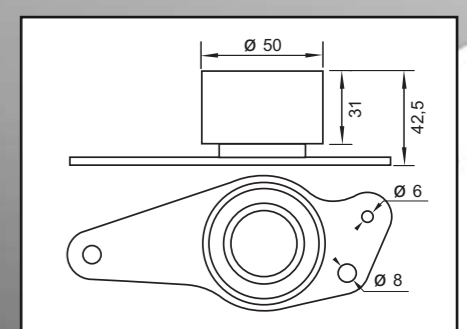

12606 7700863112

MODELO MODEL	COMB./FUEL	MOTOR ENGINE	AÑO YEAR		CÓDIGO CODE EM euromotor®		
			DESDE SINCE	HASTA TO	FIJO FIXED	MÓVIL MOBILE	NOTA NOTE

RENAULT R5 SUPERCINQUE

1.7	1721	N	F2N - F3N	03/88	03/95	1854	1173
1.6 D	1595	D	F8M 720/730	02/88	12/96	1854	1865
1.6 D	1595	D	F8M 720/730	01/90	12/96	1854	1173

RENAULT R9

1.7	1721	N	F2N - F3N	03/88	12/88	1854	1865
1.6 D	1595	D	F8M 700/720/730	03/88	12/88	1854	1865

RENAULT R11

1.7	1721	N	F2N - F3N	03/88	12/88	1854	1865
1.6 D	1595	D	F8M 700/720/730	03/88	12/88	1854	1865

RENAULT R18

2.0	1995	N	J6R 716	05/82	07/86		1817
2.2	2165	N	J7R	06/84	07/86		1817
2.1 D	2068	D	J8S	11/81	07/86	1857	1858
2.1 TD	2068	D	J8S	11/81	07/86	1857	1858

RENAULT R19

1.2	1171	N	E6F - E6J	09/88	12/95		1863
1.4	1390	N	C2J - C3J - E7J	04/89	12/95		1863
1.7	1721	N	F2N - F3N	09/88	12/95	1854	1173
1.8 16v	1764	B	F7P 704	06/89	12/95	1881	1880
1.9 D	1870	D	F8Q	09/88	12/95	1854	1173
1.9 TD	1870	D	F8Q	09/88	12/95	12606	1173

RENAULT R20

2.0	1995	N	829 700/701/702/703	10/80	12/83		1817
2.2	2165	N	851 700	10/80	12/83		1817
2.1 D	2068	D	852	10/80	12/83	1857	1858
2.1 TD	2068	D	852	10/80	12/83	1857	1858

CÓDIGO EM CÓDIGO ORIGINAL ORIGINAL CODE

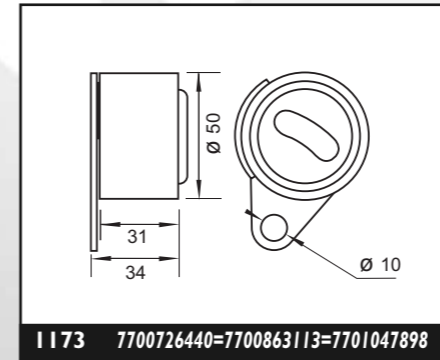

CÓDIGO EM CÓDIGO ORIGINAL ORIGINAL CODE

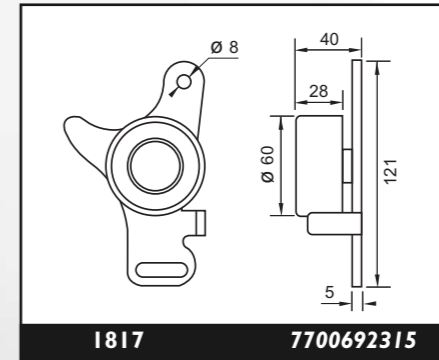

CÓDIGO EM CÓDIGO ORIGINAL ORIGINAL CODE

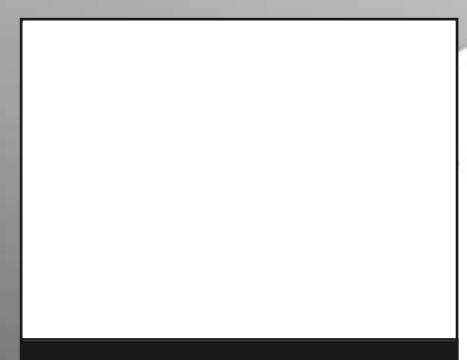
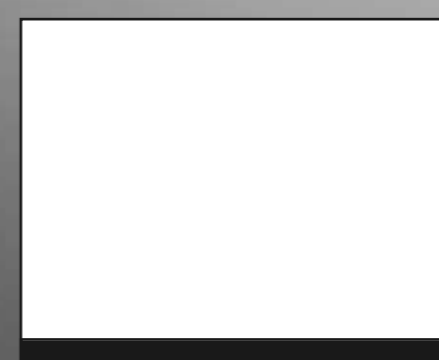
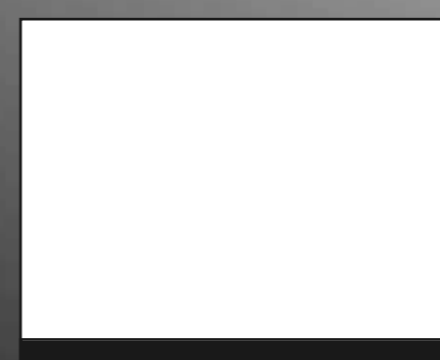
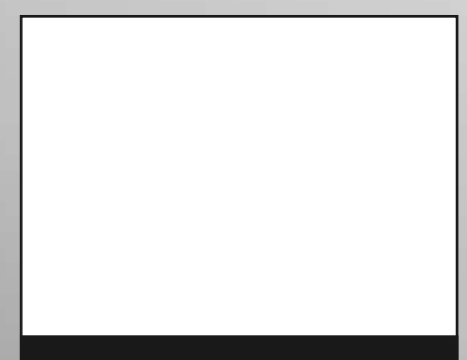
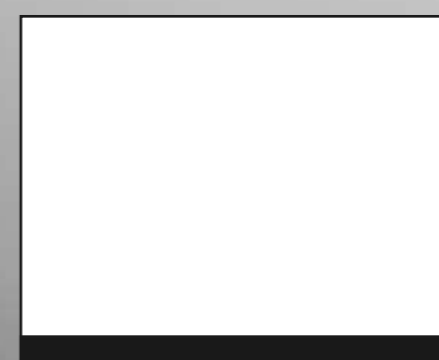
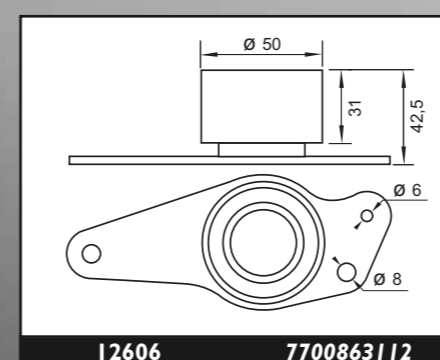
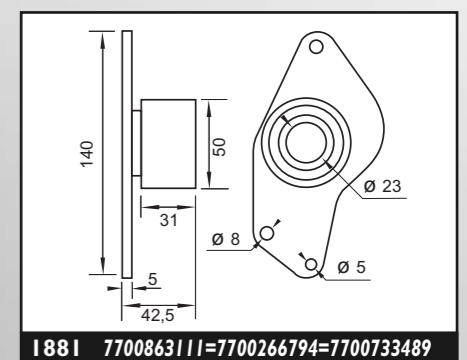
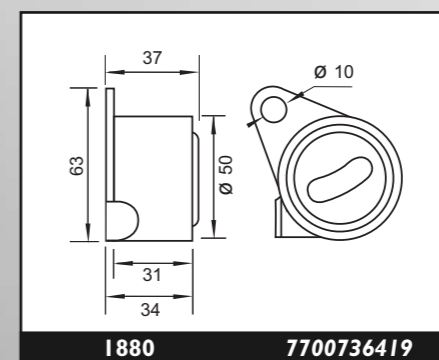
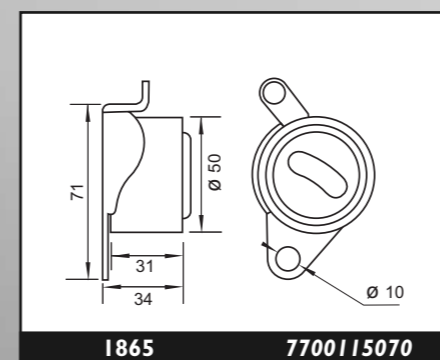
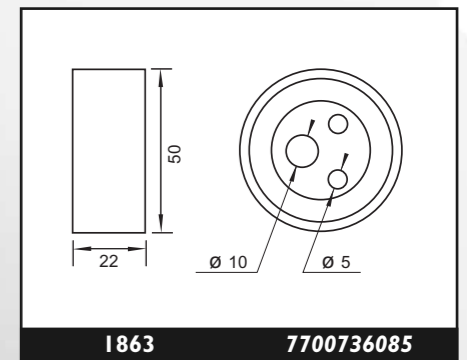
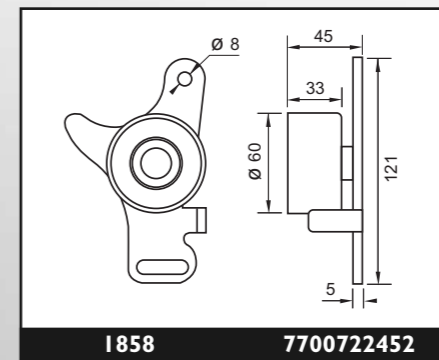
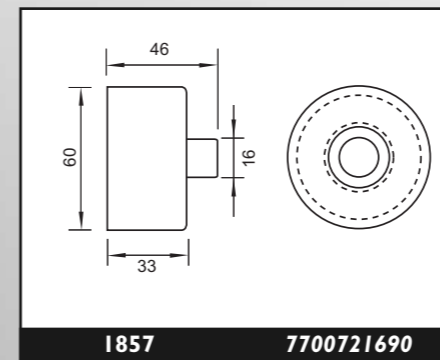
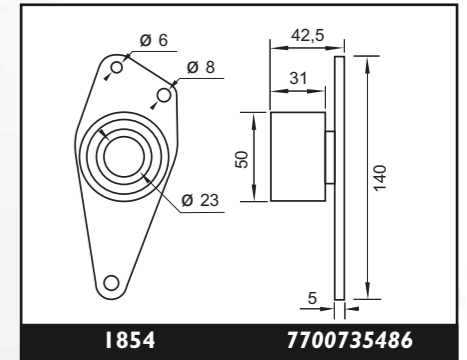

MODELO MODEL	COMB./ FUEL	MOTOR ENGINE	AÑO YEAR		CÓDIGO CODE EM euromotor®		
			DESDE SINCE	HASTA TO	FIJO FIXED	MÓVIL MOBILE	NOTA NOTE

RENAULT R21

1.4	1390	N	E6j - E7j	09/89	08/94		1863	
1.7	1721	N	F2N - F3N	03/88	08/94	1854	1173	
2.0	1995	N	J7R	03/86	09/94		1817	
2.0	1995	N	J7R	03/86	09/94		1882	Correa/ Belt 116 dientes/ teeth
2.2	2165	N	J7T	03/86	09/94		1817	
2.2	2165	N	J7t	03/86	09/94		1882	Correa/ Belt 116 dientes/ teeth
1.9 D	1870	D	F8Q	08/89	10/93	1854	1173	
2.1 D	2068	D	J8S	03/86	09/94	1857	1858	
2.1 TD	2068	D	J8S	03/86	09/94	1857	1858	

RENAULT R25

2.0	1995	N	J7R	04/84	12/93		1817	
2.0	1995	N	J7R	04/84	12/93		1882	Correa/ Belt 116 dientes/ teeth
2.2	2165	N	J7T	03/86	09/94		1817	
2.2	2165	N	J7T	03/86	09/94		1882	Correa/ Belt 116 dientes/ teeth
2.1 D	2068	D	J8S	03/86	09/94	1857	1858	
2.1 TD	2068	D	J8S	03/86	09/94	1857	1858	

RENAULT SAFRANE

2.0 12v	1995	N	J7R 734/735	04/92	07/96		1882	
2.0 16v	1995	N	N7Q	07/96	11/97	12200	1930	
2.0 16v	1995	N	N7Q	12/97		12200	1137	
2.5 16v		N	N7U	07/96	11/97	12200	1930	
2.5 16v		N	N7U	12/97		12200	1137	
2.1 D	2068	D	J8S	11/93	02/95	12173	1913	
2.2 D	2188	D	G8T	11/95		1965 12429	1112	
2.2 TD	2188	D	G8T	11/95		1965	1112	

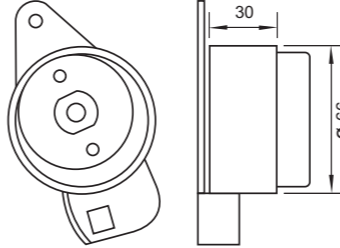
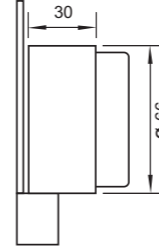
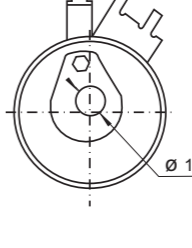
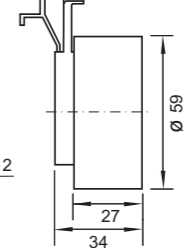
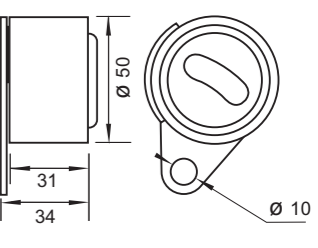
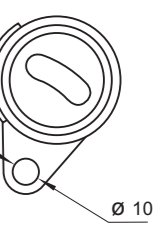
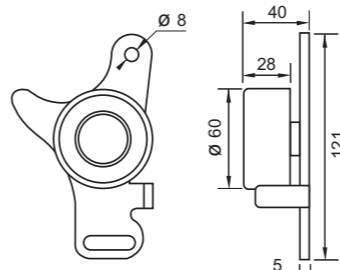
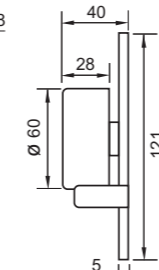
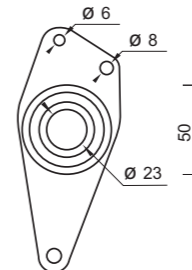
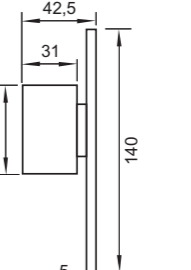
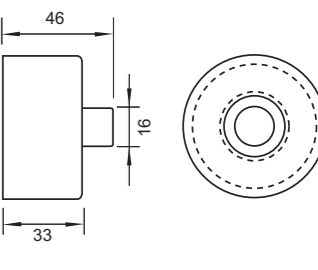
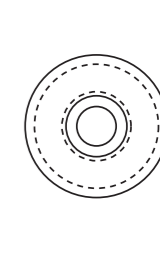
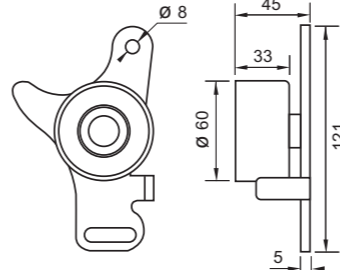
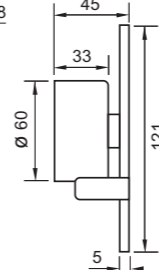
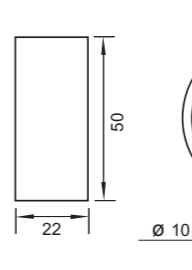
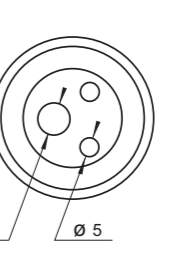
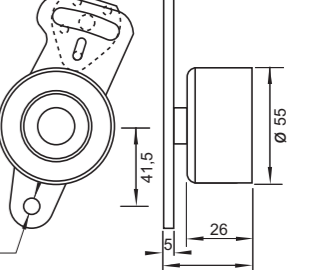
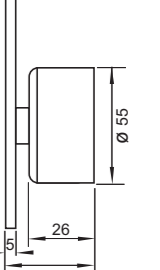
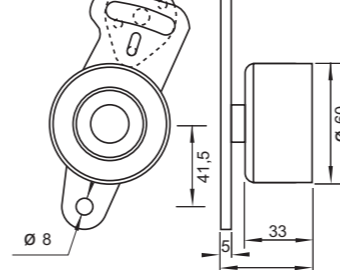
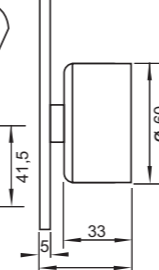
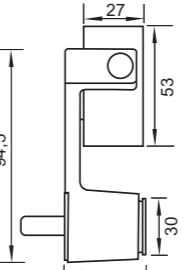
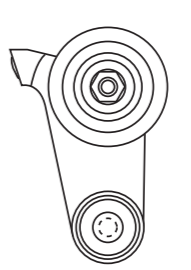
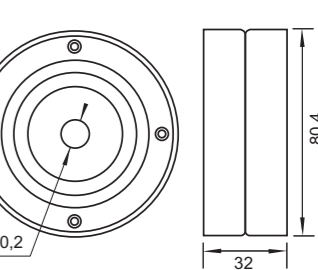
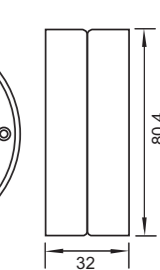
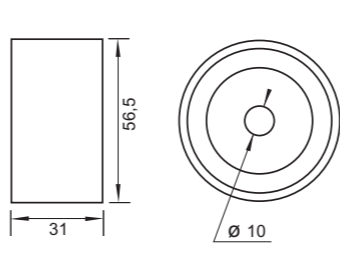
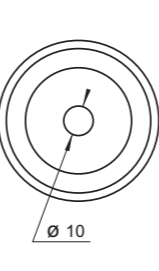
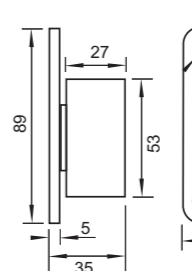
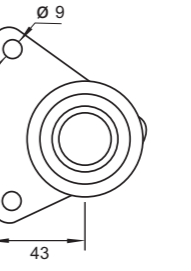
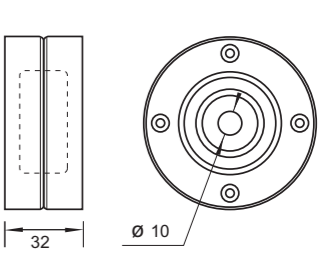
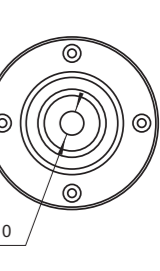
CÓDIGO CODE EM	CÓDIGO ORIGINAL ORIGINAL CODE	CÓDIGO CODE EM	CÓDIGO ORIGINAL ORIGINAL CODE	CÓDIGO CODE EM	CÓDIGO ORIGINAL ORIGINAL CODE
					
1112	7700872531=7700873731	1137	7439440329	1173	7700726440=7700863113=7701047898
					
1817	7700692315	1854	7700735486	1857	7700721690
					
1858	7700722452	1863	7700736085	1882	7700745215
					
1913	7700852114=7700871169	1930	7439135036	1965	7700862615
					
12173	7700853550	12200	7439146376	12429	7700857492

MODELO MODEL	MOTOR ENGINE	AÑO YEAR	CÓDIGO CODE EM euromotor®			FIJO FIXED	MÓVIL MOBILE	NOTA NOTE
		DESDE SINCE	HASTA TO					

RENAULT TWINGO

1.2	1149	N	D7F - D7D	03/93			1863	
1.2 16v	1149	N	D4F - D4D	01/00			12299	

RENAULT VELSATIS

2.0 16v	1998	N	F4R	06/02		12246 12424	12261	
---------	------	---	-----	-------	--	----------------	-------	--

Utilitarios

RENAULT EXPRESS

1.4	1390	N	E7J	09/91	03/98		1863	
1.6 D	1596	D	F8M	02/88	03/98	1854 1153	1173	
1.9 D	1870	D	F8Q 640 - 646 722 - 776 -	09/94	03/98	1881	1173	

RENAULT KANGOO

1.2	1149	N	D7F - 710 - 744 -	03/98			1863	
1.2 16v	1149	N	D4F - 712 - 714 -	06/00			12299	
1.4	1390	N	E7J - 780	03/98			1145	
1.6	1598	N	K7J - K7M - 700	03/98			1145	
1.6 16v	1598	N	K4M - 708 - 750	06/01		12208	12177	
1.6 16v	1598	N	K4M - 761-782-812	06/05		12208	12593	
1.5 DCi	1461	D	K9K - 700 - 702 - 704 -	06/01			12298	
1.9 D	1870	D	F8Q - 630 - 662 -	03/98		1881 1153	1173	

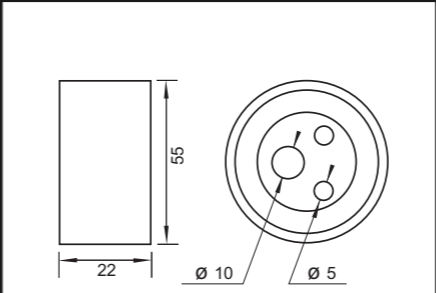
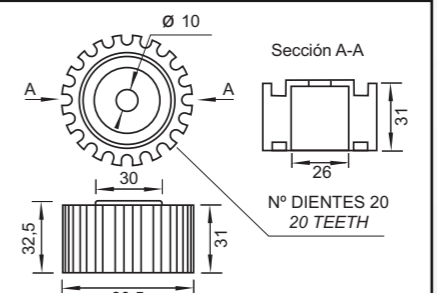
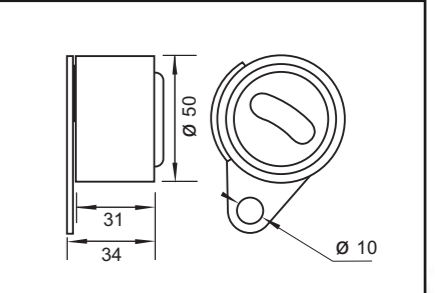
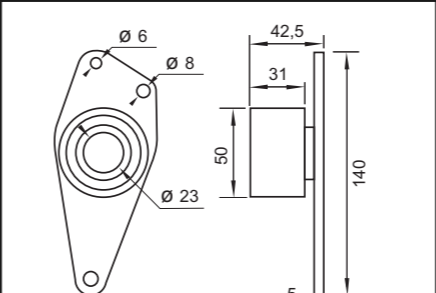
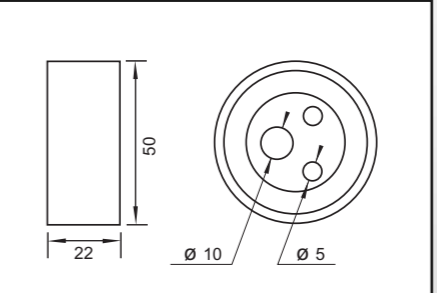
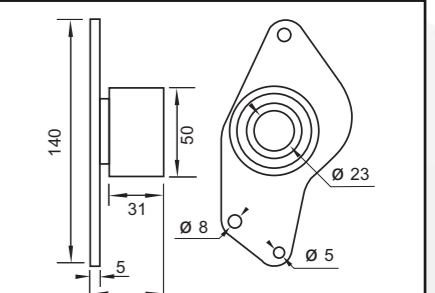
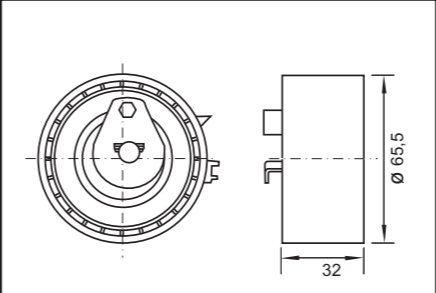
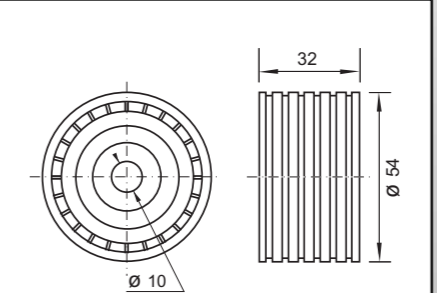
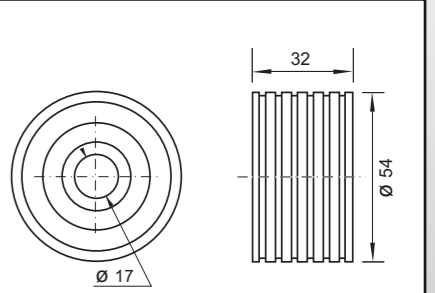
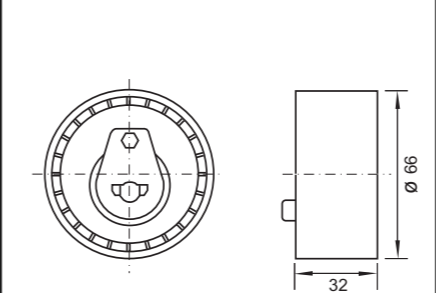
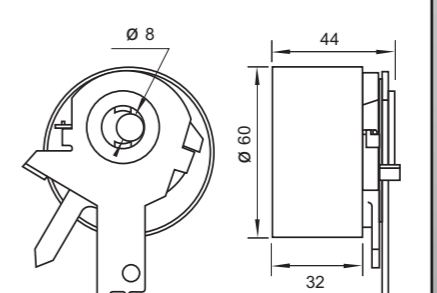
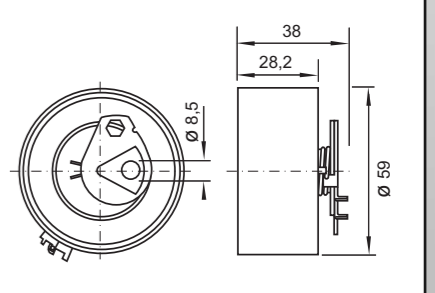
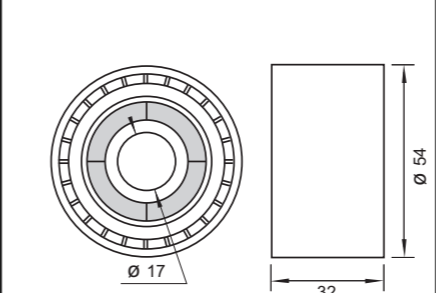
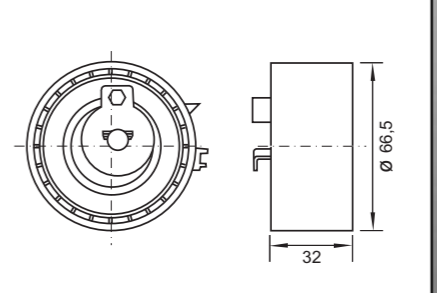
CÓDIGO CODE EM	CÓDIGO ORIGINAL ORIGINAL CODE	CÓDIGO CODE EM	CÓDIGO ORIGINAL ORIGINAL CODE	CÓDIGO CODE EM	CÓDIGO ORIGINAL ORIGINAL CODE			
			1145	7700273277	1153	7700107249	1173	7700726440=7700863113=7701047898
			1854	7700735486	1863	7700736085	1881	7700863111=7700266794=7700733489
			12177	7700108117	12208	7700107150	12246	8200064664
			12261	8200061345	12298	8200102941	12299	8200035827=8200103069
			12424	7700108626	12593	8200347761=8200191324		

MODELO MODEL	COMB./FUEL	MOTOR ENGINE	AÑO YEAR		CÓDIGO CODE EM euromotor®		
			DESDE SINCE	HASTA TO	FIJO FIXED	MÓVIL MOBILE	NOTA NOTE

RENAULT KANGOO

1.9 DTi	1870	D	F9Q - 780 - 782 -	02/00		12425 1153	12201	
1.9 DCi	1870	D	F9Q - 790 -	09/00		12425 1153	1173	

RENAULT MASTER

2.0	1995	N	J5R	08/80	07/98		1817	
2.0	1995	N	J5R - J7T	08/80	07/98		1882	
1.9 DTi	1870	D	F9Q	09/00		12425 1153	12201	
2.1 D	2068	D	J8S	08/80	01/98		1857	1913
2.1 D	2068	D	J8S	02/95	07/98	12173	1913	
2.2 DCi	2188	D	G9T	09/00		FU15492	14208	
2.5 D	2500	D	S8U - S9U	08/80	07/98	1816	1821	
2.5 D	2500	D	S8U - S9U	08/80	07/98	12389	12503	Con base With plate
2.5 TD	2500	D	S8U - S9U	08/80	07/98	12389	12503	
2.5 TD	2500	D	S8U - S9U	08/80	07/98	1816	1821	
2.5 DCi	2500	D	G9U720-750-754	09/03		FU15492	14208	
2.8 DTi	2799	D	S9W702	08/98		1816	1816	

RENAULT TRAFIC

1.7	1721	N	FIN	02/88	08/94	1854	1173	
2.0	1995	N	J5R	03/80	10/97		1882	
2.2		N	J7T	03/80	10/97		1882	

CÓDIGO CODE EM	CÓDIGO ORIGINAL ORIGINAL CODE	CÓDIGO CODE EM	CÓDIGO ORIGINAL ORIGINAL CODE	CÓDIGO CODE EM	CÓDIGO ORIGINAL ORIGINAL CODE
-------------------	----------------------------------	-------------------	----------------------------------	-------------------	----------------------------------

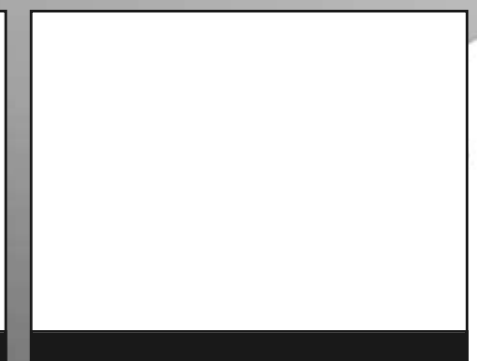
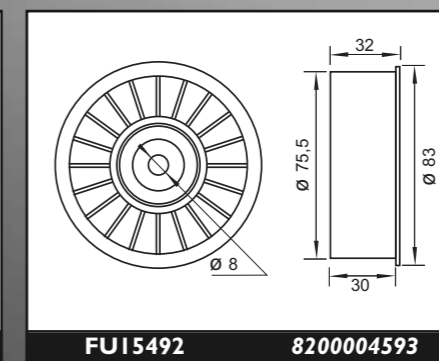
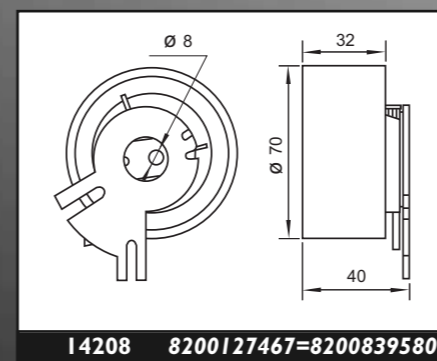
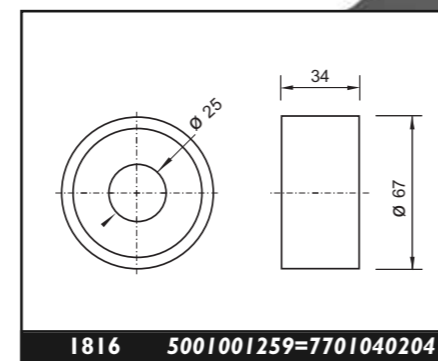
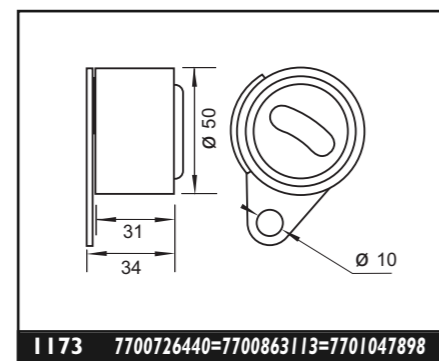
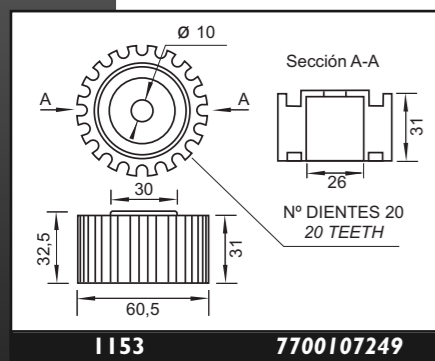
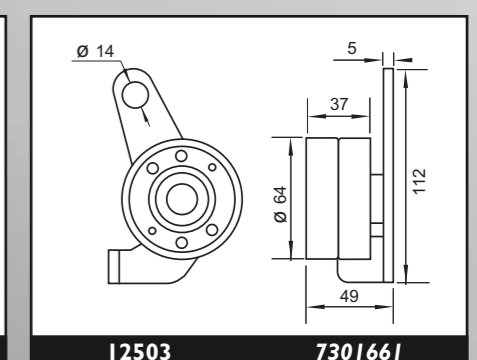
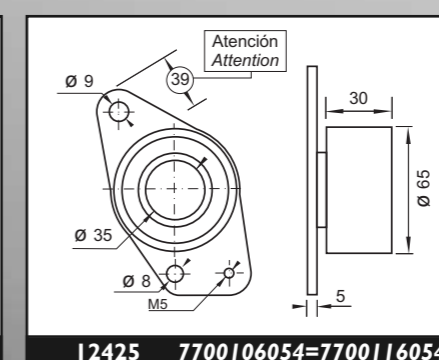
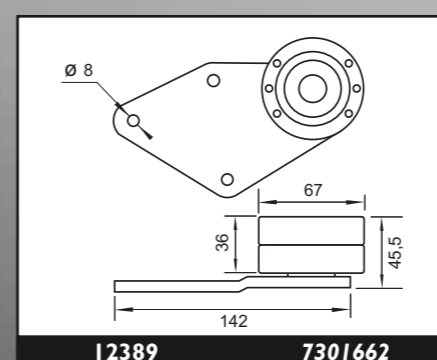
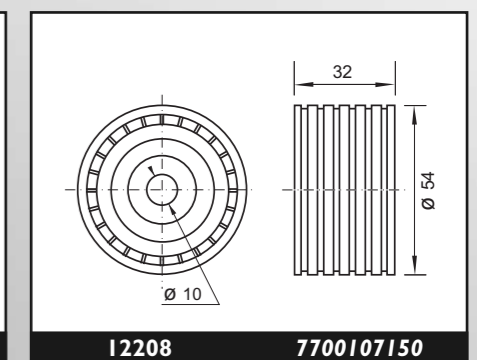
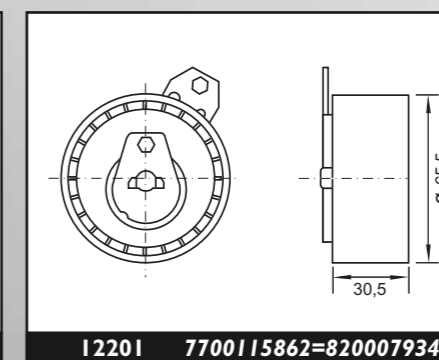
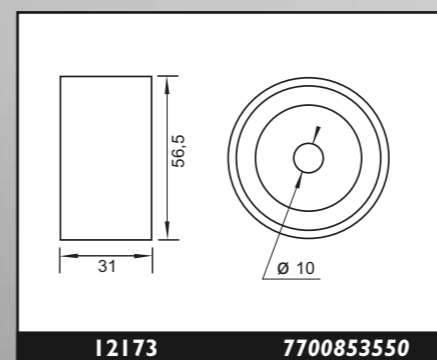
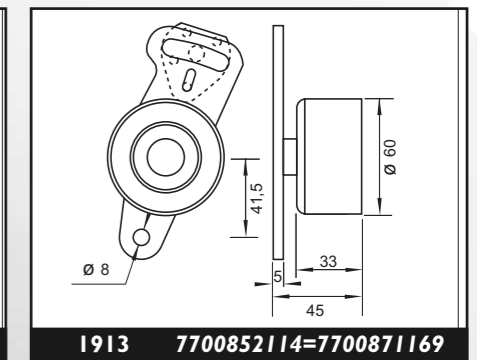
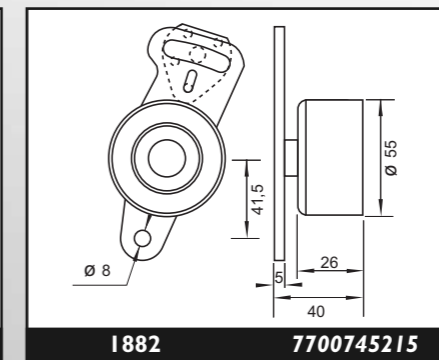
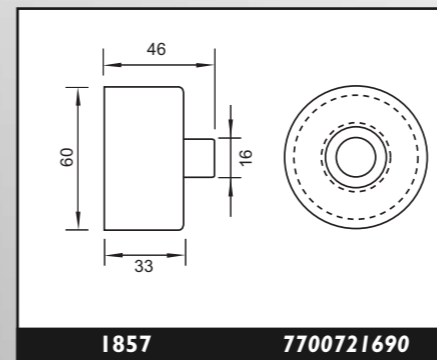
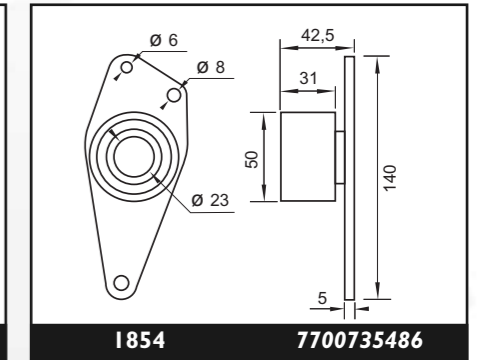
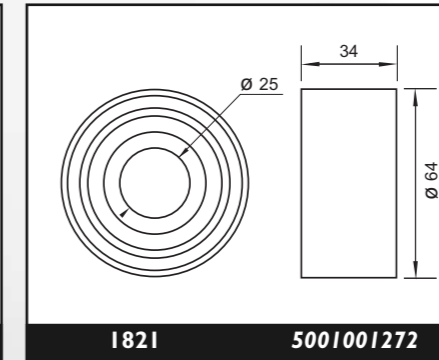
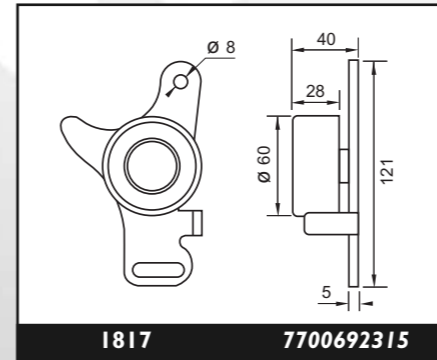

MODELO MODEL	AÑO YEAR	MOTOR ENGINE	AÑO YEAR		CÓDIGO CODE		
			DESDE SINCE	HASTA TO	FIJO FIXED	MÓVIL MOBILE	NOTA NOTE

RENAULT TRAFIC

2.0	1998	N	F4R	03/01		12208 12424	12261	
1.9 D	1870	D	F8Q	06/97		1854 1153	1173	
2.1 D	2068	D	852	03/80	10/97	1857	1913	
2.5 D	2499	D	8140.61.240	05/89		1816	1821	Sólo rodam. Bearing only
2.5 D	2499	D	8140.61.240	05/89		12389	12503	Con base With plate

CÓDIGO CODE	EM	CÓDIGO ORIGINAL ORIGINAL CODE	CÓDIGO CODE	EM	CÓDIGO ORIGINAL ORIGINAL CODE	CÓDIGO CODE	EM	CÓDIGO ORIGINAL ORIGINAL CODE
1153		7700107249	1173		7700726440=7700863113=7701047898	1816		5001001259=7701040204
1821		5001001272	1854		7700735486	1857		7700721690
1913		7700852114=7700871169	12208		7700107150	12261		8200061345
12389		7301662	12424		7700108626	12503		7301661

EM euromotor®

VERSION PDF 2010

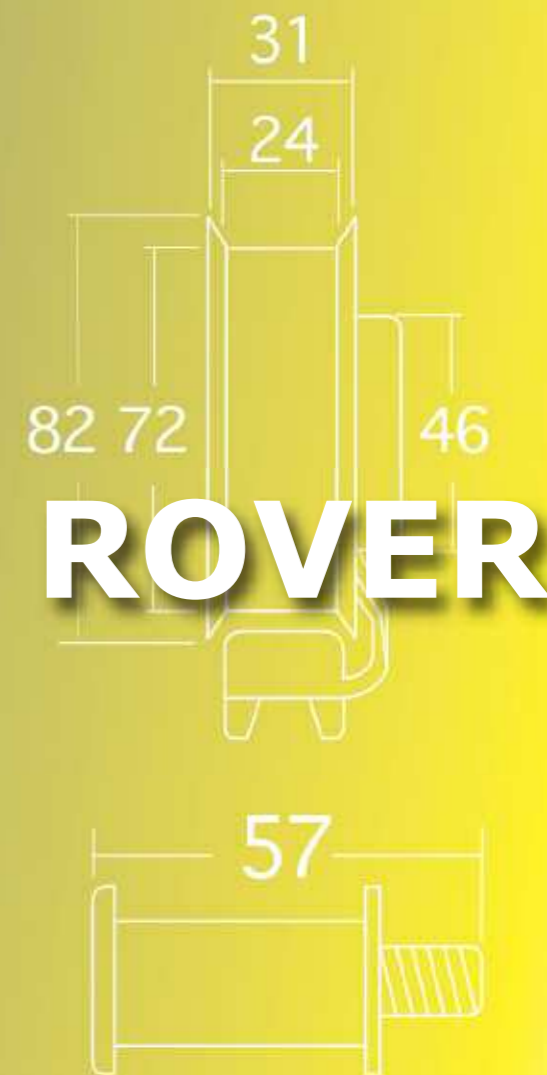

ROVER



MODELO MODEL	COMB./FUEL	MOTOR ENGINE	AÑO YEAR		CÓDIGO CODE EM euromotor®		
			DESDE SINCE	HASTA TO	FIJO FIXED	MÓVIL MOBILE	NOTA NOTE

ROVER 111

111	1119	N	11K2A- 11K2D	03/90	12/98		1895	
-----	------	---	--------------	-------	-------	--	------	--

ROVER 114

114	1396	N	14K2A - 14K2D	03/90	12/98		1895	
114 GTi	1396	N	14K4C/D/F	03/90	12/98		1894	
114 GSi	1396	N	14K4C/D/F	03/90	12/98		1894	
114 D	1527	D	TUD5	12/94	12/98	1862	1861	

ROVER 115

115 D	1527	D	TUD5	12/94	12/98	1862	1861	
-------	------	---	------	-------	-------	------	------	--

ROVER 211

211	1119	N	11K2A - 11K2D	01/98	03/00		1895	
-----	------	---	---------------	-------	-------	--	------	--

ROVER 213

213 S	1342	N	EV2	09/85	09/89		12511	
-------	------	---	-----	-------	-------	--	-------	--

ROVER 214

214	1396	N	14K2A - 14K2D	09/93	10/95		1895	
214 GSi	1396	N	14K4C/D/F	10/89	10/95		1894	
214 Si	1396	N	14K4C/D/F	10/89	10/95		1894	
214 i	1396	N	14K2F	11/95	03/00		1895	
214 Si	1396	N	14K4F	11/95	03/00		1894	

ROVER 216

216	1598	N	I6H	03/85	09/89		1896	
216 Coupé	1590	N	D16A8	10/92			1927	
216 GTi	1590	N	D16Z2 - D16A8	10/89	10/95		1927	
216 GSi	1590	N	D16Z2 - D16A8	10/89	10/95		1927	
216 Si	1588	N	I6K4F	11/95	03/00		1927	

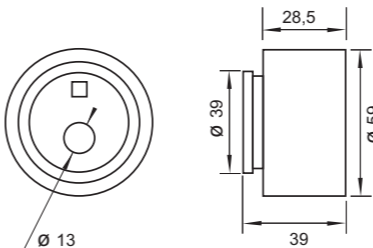
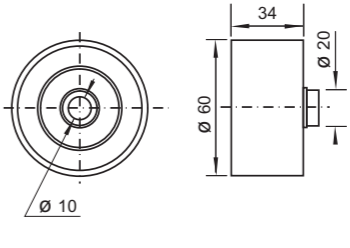
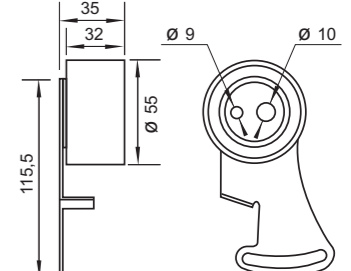
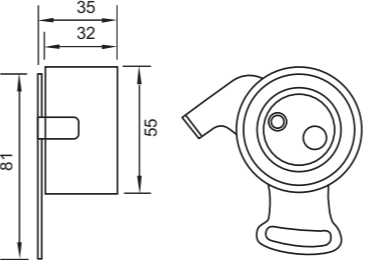
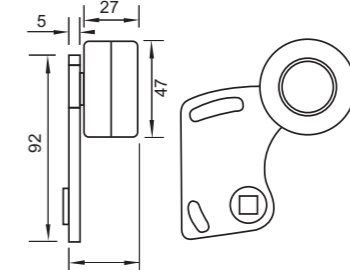
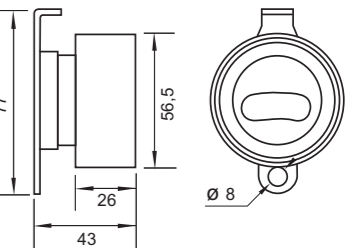
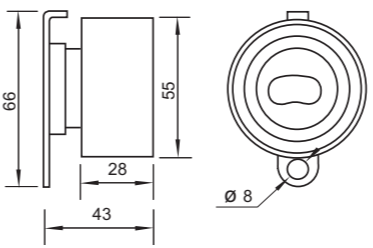
CÓDIGO CODE EM	CÓDIGO ORIGINAL ORIGINAL CODE	CÓDIGO CODE EM	CÓDIGO ORIGINAL ORIGINAL CODE	CÓDIGO CODE EM	CÓDIGO ORIGINAL ORIGINAL CODE
	LHP 10013		LHV10002-LHV100080		CDU3558-LHP10015
	CDU3559-LHP10014		CAM9135=CAM9153		FDU1055
	DBP9291				

MODELO MODEL	COMB./ FUEL	MOTOR ENGINE	AÑO YEAR		CÓDIGO CODE			NOTA NOTE
			DESDE SINCE	HASTA TO	FIJO FIXED	MÓVIL MOBILE	EM euromotor®	

ROVER 218

218Vi	1796	N	18K4K (VVC)	11/95	03/00		1894	Tens. mecánico Mechanic tens.
218TD	1769	D	XUD7TE	09/91	10/92	1814	1813	
218TD	1769	D	XUD7TE	11/92	10/95	1900	1901	

ROVER 220

220 GTi	1994	N	20M4F	09/91	10/95		1897	1897
220 D	1994	D	20T2R - 20T2N	11/95	03/00	12547	12546	12432
220 SDi	1994	D	20T2R - 20T2N	11/95	03/00	12547	12546	12432
220 DT	1994	D	20T2R - IDT	04/00		12547	12546	12433

ROVER 25

1.4 16v	1396	N	14KF - 14KM	04/00			1894	
1.6 16v	1588	N	16K4F	04/00			1927	
1.8 16v	1796	N	18K4F	04/00			1894	Tens. mecánico Mechanic tens.
2.0 IDT	1994	D	L20	04/00		12547	12433	

ROVER 414

414 GSi	1396	N	14K4C/D/F	04/90	04/95		1894	Tens. mecánico Mechanic tens.
414 Si	1396	N	14K4C/D/F	04/90	04/95		1894	Tens. mecánico Mechanic tens.
414 Si	1396	N	14K4F	05/95	03/00		1894	Tens. mecánico Mechanic tens.
414	1396	N	14K4F	04/94	11/98		1894	Tens. mecánico Mechanic tens.
414 Tourer	1396	N	14K4F	04/94	11/98		1894	Tens. mecánico Mechanic tens.
414 Tourer	1590	N	DI6Z2-DI6A8	04/94	11/98		1927	

CÓDIGO CODE	EM	CÓDIGO ORIGINAL ORIGINAL CODE	CÓDIGO CODE	EM	CÓDIGO ORIGINAL ORIGINAL CODE	CÓDIGO CODE	EM	CÓDIGO ORIGINAL ORIGINAL CODE
----------------	----	----------------------------------	----------------	----	----------------------------------	----------------	----	----------------------------------

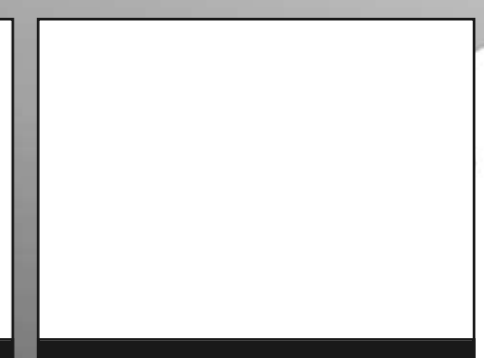
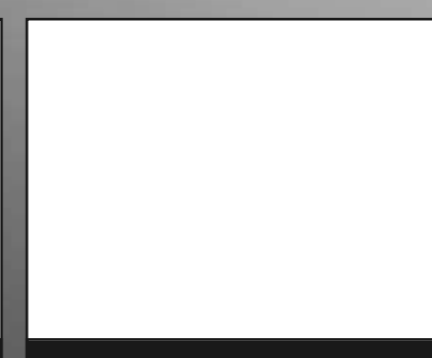
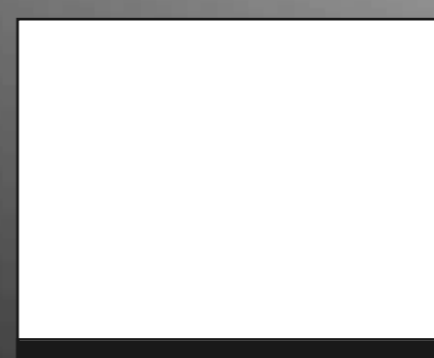
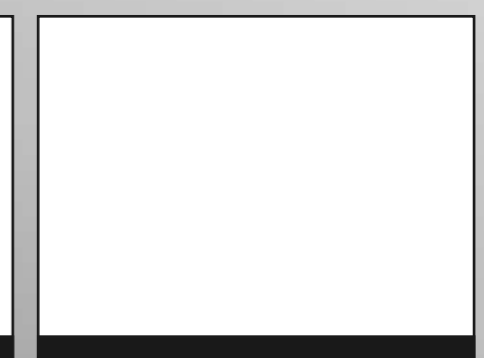
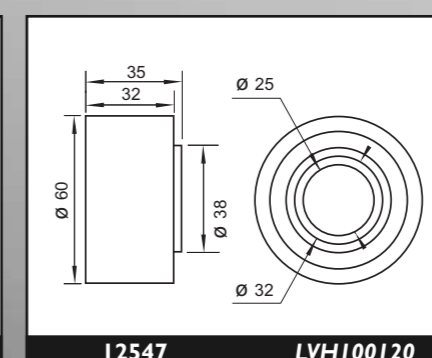
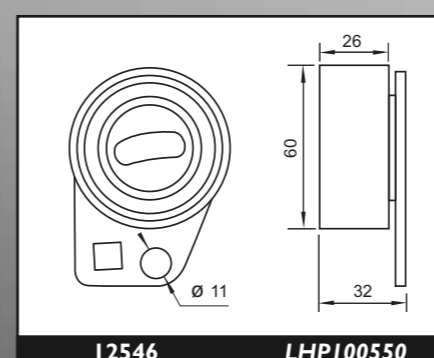
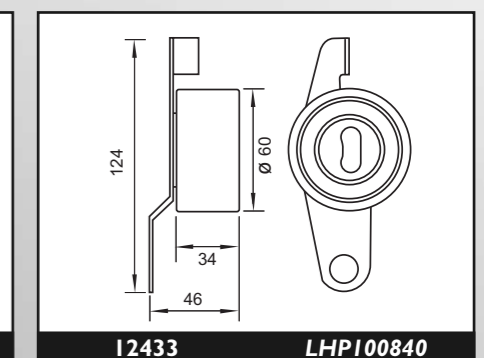
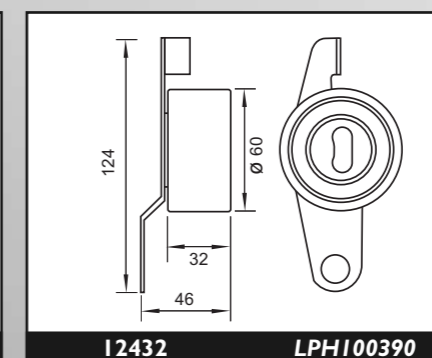
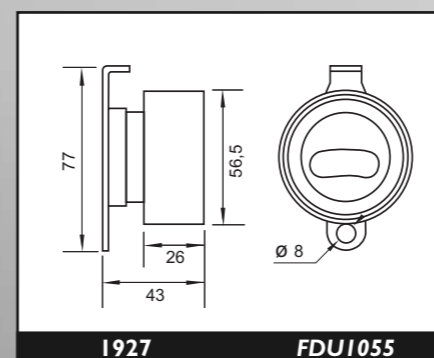
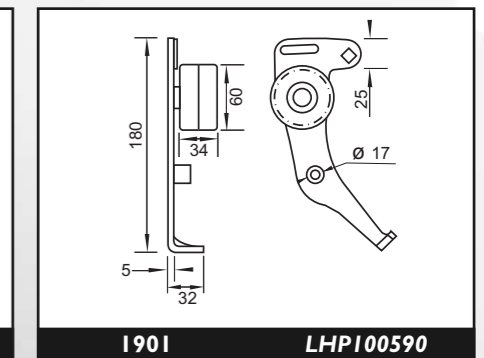
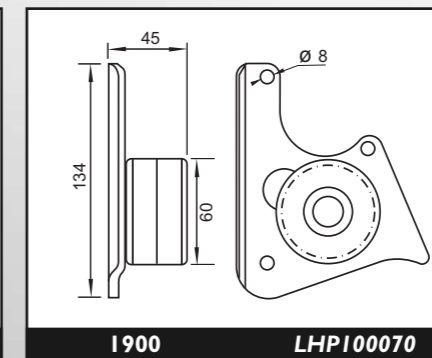
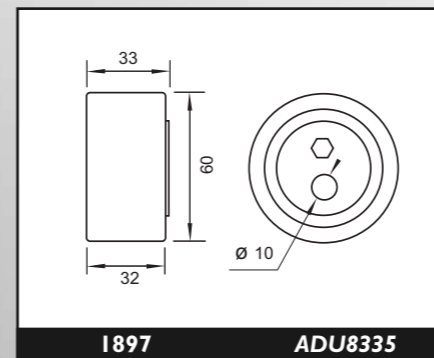
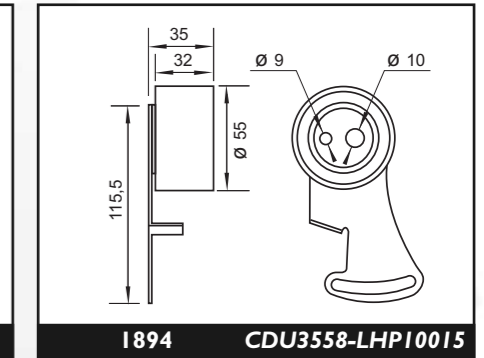
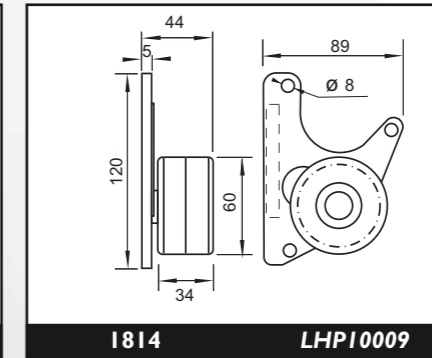
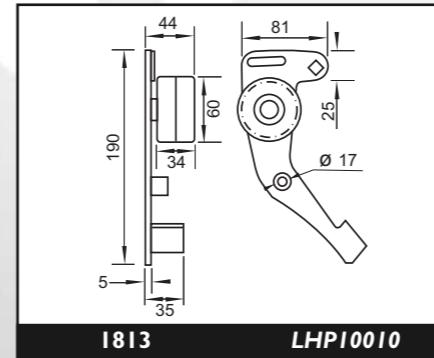

MODELO MODEL	COMB./ FUEL	MOTOR ENGINE	AÑO YEAR		CÓDIGO CODE EM euromotor®		
			DESDE SINCE	HASTA TO	FIJO FIXED	MÓVIL MOBILE	NOTA NOTE

ROVER 416

416 GSi	1590	N	D16Z2-D16A8	06/90	04/95		1927	
416 GTi	1590	N	D16Z2 - D16A8	06/90	04/95		1927	
416 Si	1588	N	I6K4F	05/95	03/00		1927	
416 Si	1590	N	D16Y2	06/95	03/00		1927	

ROVER 418

418 D	1769	D	XUD7TE	09/91	10/92	1814	1813	
418 D	1769	D	XUD7TE	11/92	04/95	1900	1901	
418TD	1769	D	XUD7TE	09/91	10/92	1814	1813	
418TD	1769	D	XUD7TE	11/92	04/95	1900	1901	
418 D Tourer	1769	D	XUD7TE	05/94	11/98	1900	1901	
418TD Tourer	1769	D	XUD7TE	05/94	11/98	1900	1901	

ROVER 420



420 GSi	1994	N	20M4F	02/92	04/95		1897 1897	
420 GTi	1994	N	20M4F	02/92	04/95		1897 1897	
420 D	1994	D	20T2R - 20T2N	05/95	03/00	12547 12546	12433	
420 Di	1994	D	20T2R - 20T2N	05/95	03/00	12547 12546	12433	
420 iDT	1994	D	20T2R	04/00		12547 12546	12433	

ROVER 45

1.4, 1.8	1396	N	I4K4F - I8K4F	04/00			1894	
1.6	1588	N	I6K4F	04/00			1927	
2.0 IDT	1994	D	L20	04/00		12547	12433	

ROVER 618

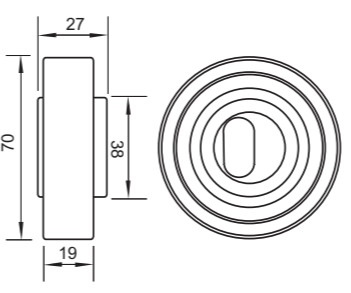
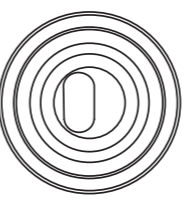
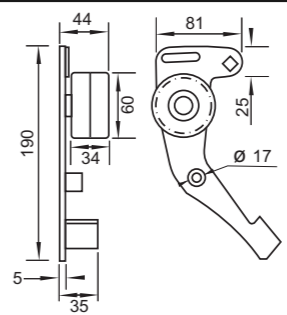
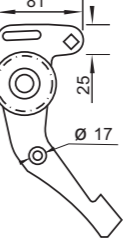
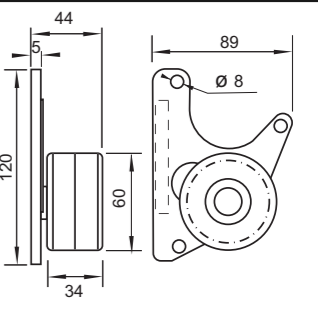
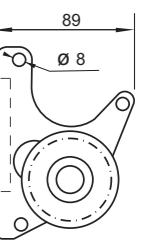
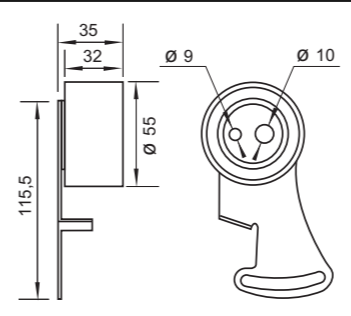
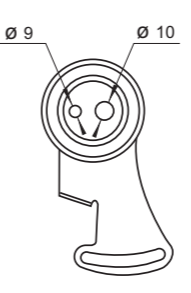
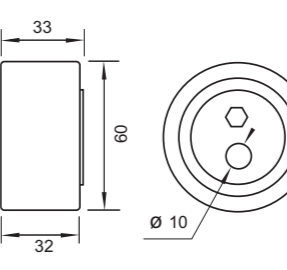
618 i	1850	N	F18A3	03/96	02/99		1178	
618 i	1850	N	F18A3	03/96	02/99		1905	

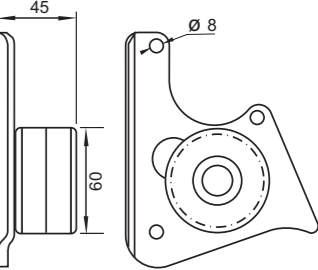
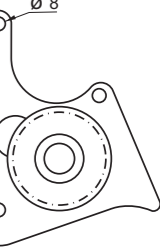
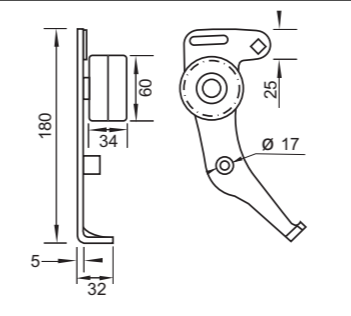
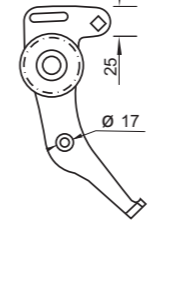
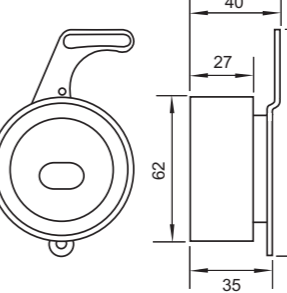
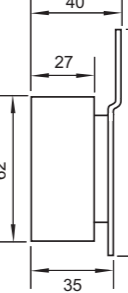
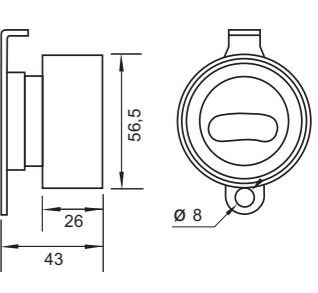
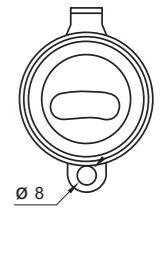
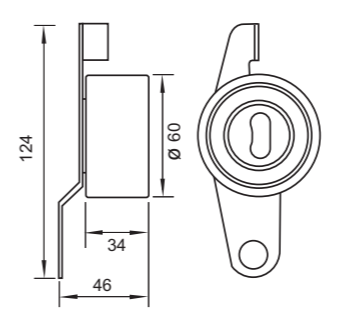
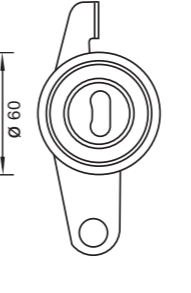
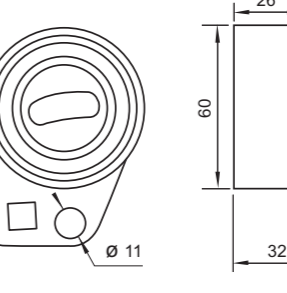
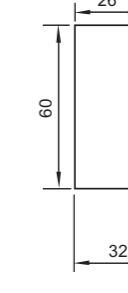
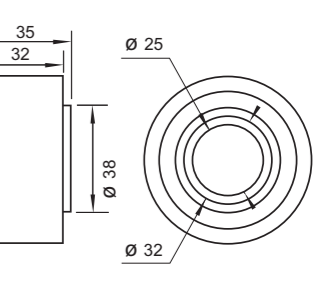
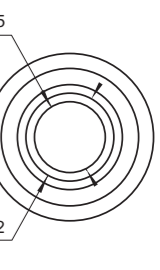
CÓDIGO CODE EM	CÓDIGO ORIGINAL ORIGINAL CODE	CÓDIGO CODE EM	CÓDIGO ORIGINAL ORIGINAL CODE	CÓDIGO CODE EM	CÓDIGO ORIGINAL ORIGINAL CODE
					
1178	LHP100480	1813	LHP10010	1894	CDU3558-LHP10015
					
1894	CDU3558-LHP10015	1897	ADU8335	1900	LHP100070
					
1901	LHP100590	1905	LHP100450	1927	FDU1055
					
12433	LHP100840	12546	LHP100550	12547	LVH100120

MODELO MODEL	AÑO YEAR	MOTOR ENGINE	CÓDIGO CODE		FIJO FIXED	MÓVIL MOBILE	NOTA NOTE
			DESDE SINCE	HASTA TO			

ROVER 620

620 i	1997	N	F20Z1 - F20Z2	08/93	02/99		1178 1905
620 Si	1997	N	F20Z1 - F20Z2	08/93	02/99		1178 1905
620 SDi	1994	D	20T2N	12/94	12/99	12547	12432 12546
620 IDT	1994	D	20T2R	01/00		12547 12546	

ROVER 623

623 Si	2259	N	H23A3	08/93	02/99		1178 1905
--------	------	---	-------	-------	-------	--	--------------

ROVER 75

1.8	1796	N	K1.8	02/99			1894	Tens. mecánico Mechanic tens.
-----	------	---	------	-------	--	--	------	----------------------------------

ROVER 820

820	1994	N	20M4 - 20H	10/88	02/99		1897
820	1996	N	20HDM16	10/86	02/99	12547	1897

ROVER MAESTRO

1.6	1598	N	S16H	01/84	01/95		1896
2.0	1994	N	20H	01/84	01/95		1897

ROVER METRO

1.1	1119	N	11K2	08/90	11/94		1895
1.4 16v	1396		14K4C - 14K4D	03/90	12/98		1894
1.4 D	1360	D	TUD3		08/90	1862	1861
1.5 D	1527	D	TUD5	12/94	12/98	1862	1861

ROVER MG

1.8	1796	N	18K4F- 18K4K(VVC)	10/95			1894
1.8VVC	1796	N	18K4F- 18K4K(VVC)	10/95			1894

CÓDIGO CODE	EM	CÓDIGO ORIGINAL ORIGINAL CODE	CÓDIGO CODE	EM	CÓDIGO ORIGINAL ORIGINAL CODE	CÓDIGO CODE	EM	CÓDIGO ORIGINAL ORIGINAL CODE
----------------	----	----------------------------------	----------------	----	----------------------------------	----------------	----	----------------------------------

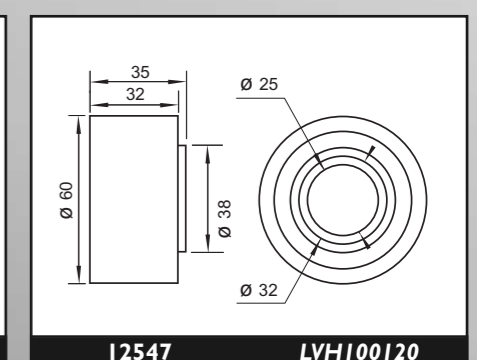
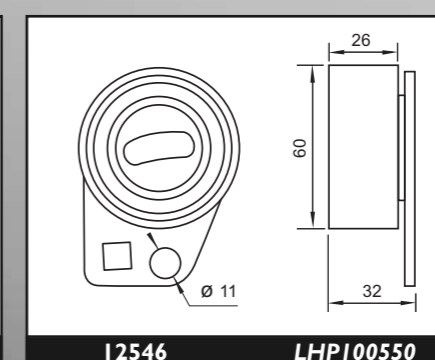
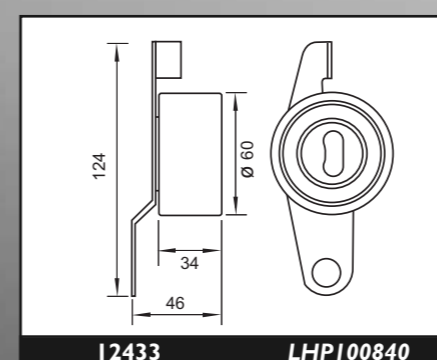
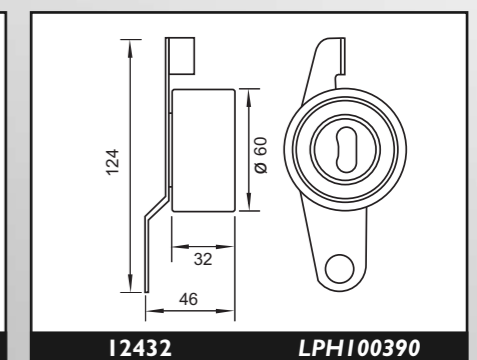
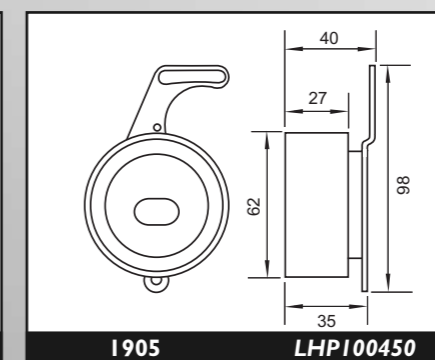
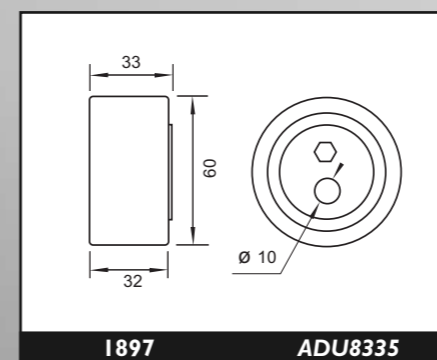
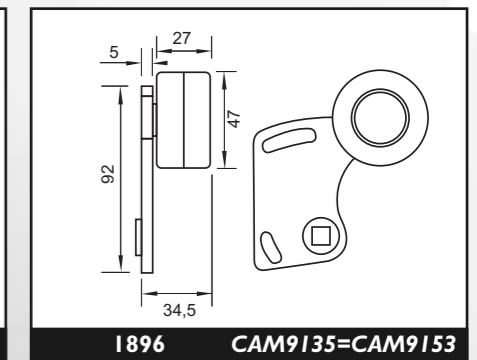
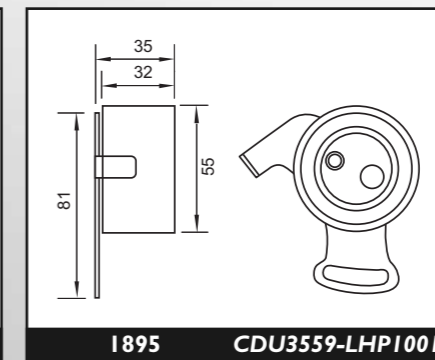
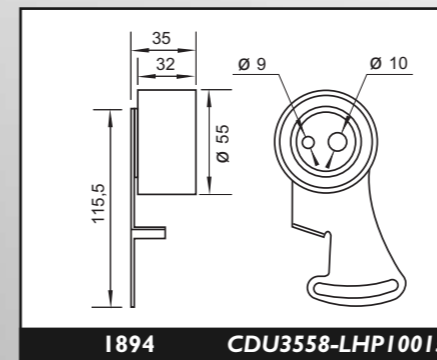
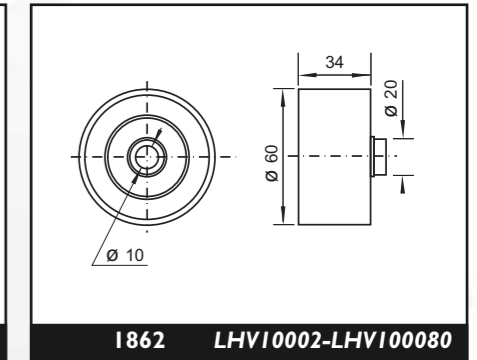
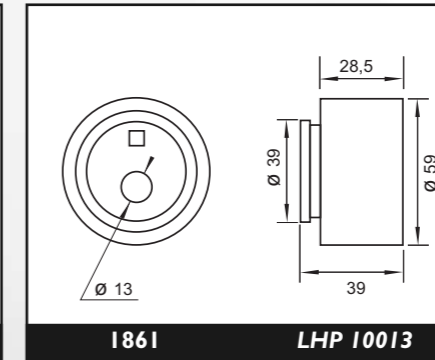
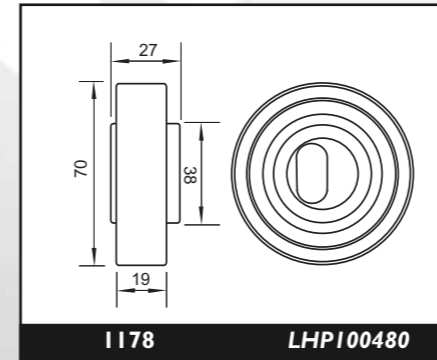

EM euromotor®

VERSION PDF 2010



$\varnothing 18$

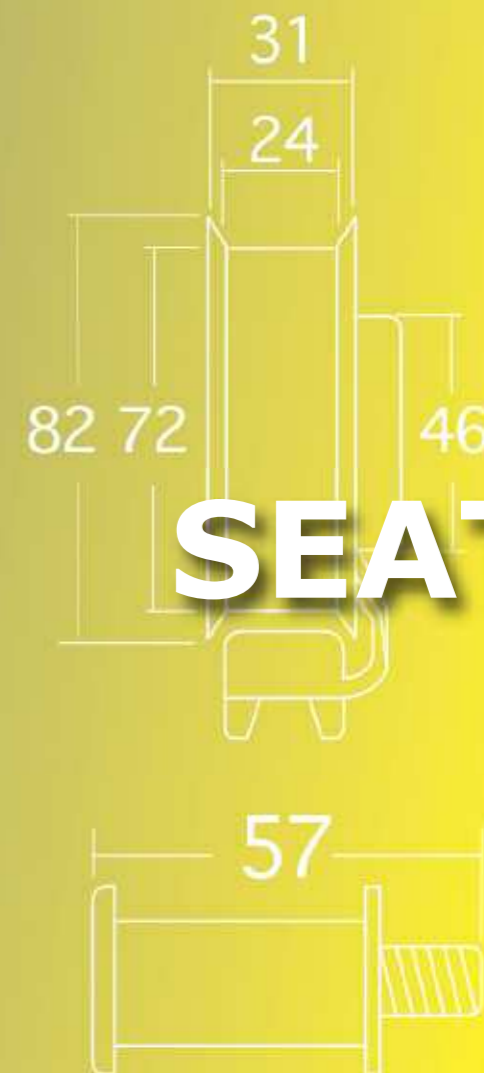

SEAT







MODELO MODEL	COMB./FUEL	MOTOR ENGINE	AÑO YEAR		CÓDIGO CODE EM euromotor®		
			DESDE SINCE	HASTA TO	FIJO FIXED	MÓVIL MOBILE	NOTA NOTE

SEAT ALHAMBRA

1.8T 20v	178	N	AJH	07/97		12242 12478	12240	(150 cv)
1.8T 20v	1781	N	AWC	06/00		12478 12242	12240	
2.0i	1984	N	ADY	09/95			1805	
2.0i	1984	N	ATM	09/95			1805	(115 cv)
2.0i	1984	N	ABF	08/96	06/00		1129	(150 cv)
2.0i	1984	N	AZH	04/00			1157	
1.9TDi	1896	D	IZ-AHU-AFN -AUG	04/96		1128	1104	
1.9TDI	1896	D	AUY - ANU	09/98	09/02	12238	12239	(115cv)
1.9TDi	1896	D	AUY - ASZ - ANU	10/02		12474	12458	(130 cv)

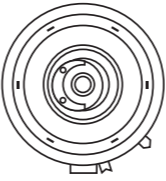
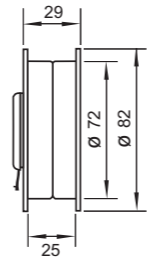
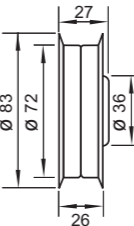
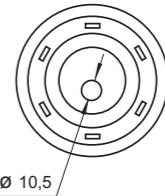
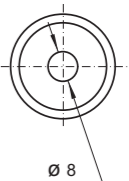
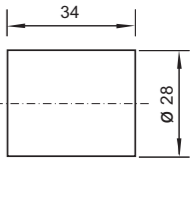
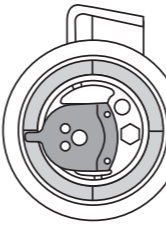
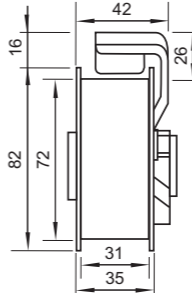
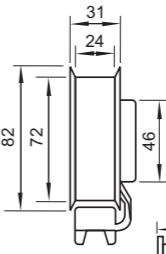
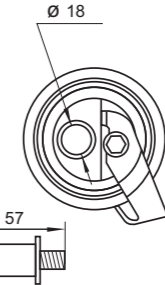
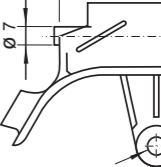
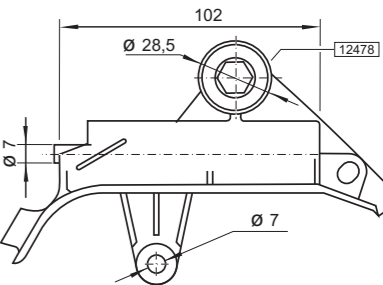
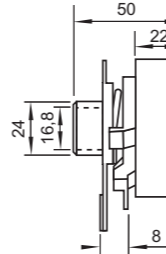
SEAT AROSA

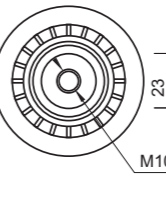
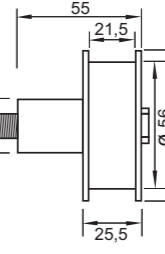
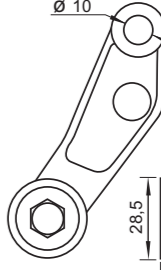
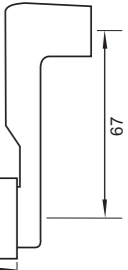
1.0	999	N	AER - ALL	01/97			12283	Hasta Up to chassis 014000
1.0	999	N	ALD - AUC - ANV	05/97			12283	
1.4	1390	N	AEX - APQ - AKV				12283	
1.4	1390	N	AKK - AUD - ANW				12283	
1.4 16v	1390	N	AHW	01/98		12438 12440	12549 12550	Hasta motor Up to engine 160000
1.4 16v	1390	N	AFK-AQQ-AUB-ANM	01/00		12438 12440	12549 12550	Desde motor From engine 160001
1.4TDi	1422	D	AMF	01/00		12238	12484	Hasta motor Up to engine 000500
1.4TDi	1422	D	AMF	01/00		12238	12239	Desde motor From engine 000501

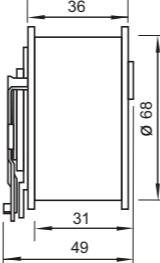
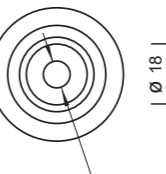
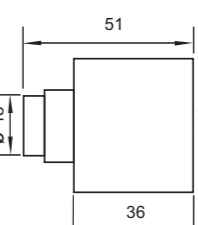
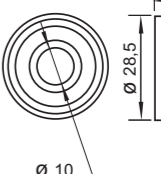
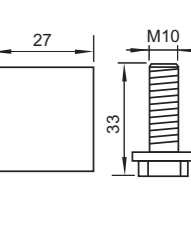
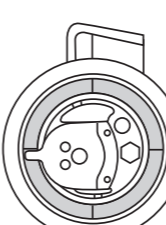
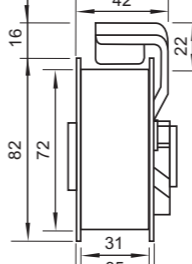
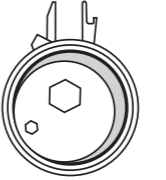
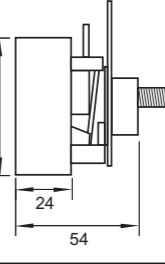
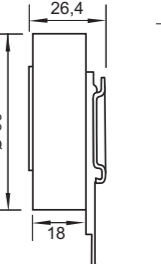
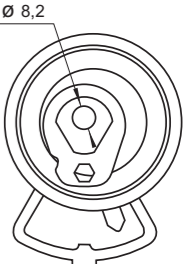
CÓDIGO CODE EM	CÓDIGO ORIGINAL ORIGINAL CODE	CÓDIGO CODE EM	CÓDIGO ORIGINAL ORIGINAL CODE	CÓDIGO CODE EM	CÓDIGO ORIGINAL ORIGINAL CODE
					
1157	059109243J	1805	026109243A=026109243E	12238	045109244A
					
12239	045109243C	12240	06B109243D	12242	06B109477
					
12283	030109243V=030109243K	12438	036109244D	12440	036109181A
					
12458	038109243M	12474	038109244J	12478	06B109244
					
12484	05109243B	12549	036109243E=036109243L= 036109243R=036109243AB	12550	036109243S

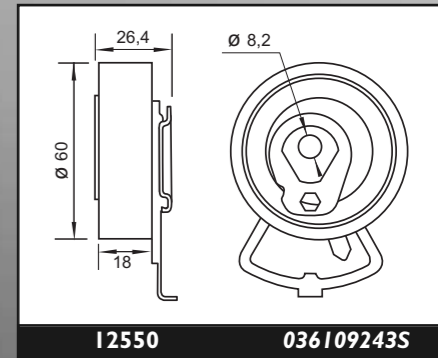
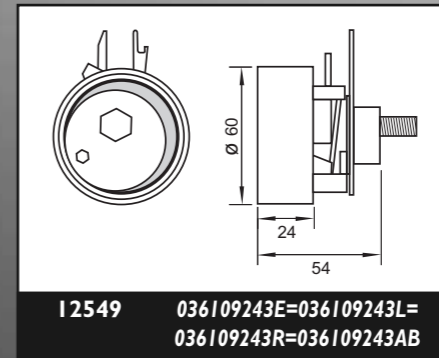
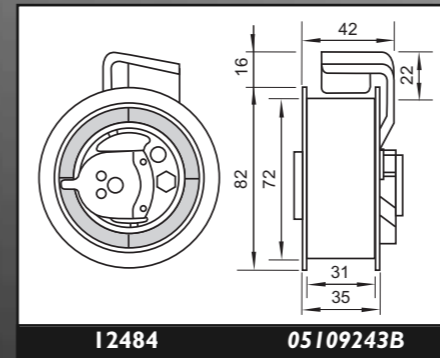
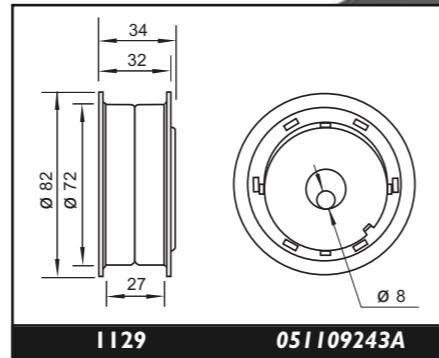
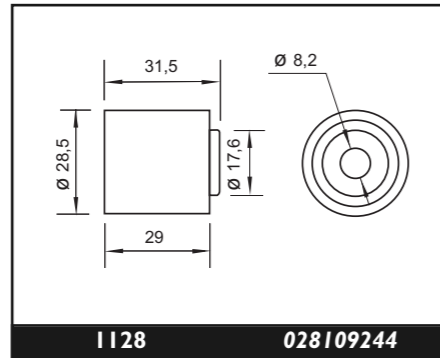
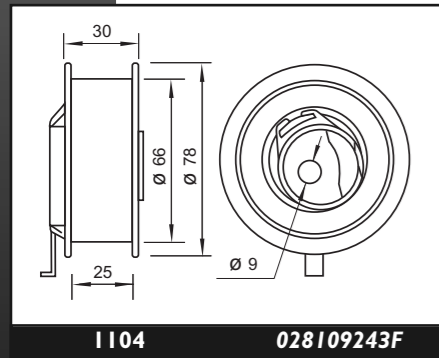

MODELO MODEL	COMB./FUEL	MOTOR ENGINE	AÑO YEAR		CÓDIGO CODE		
			DESDE SINCE	HASTA TO	FIJO FIXED	MÓVIL MOBILE	NOTA NOTE

SEAT AROSA

I.7 SDi	1716	D	AKU	08/97		1128	12548	
---------	------	---	-----	-------	--	------	-------	--

SEAT ALTEA

I.6	1595	N		05/04			1157	
I.9 TDI	1896	D	AKC -			12474	12458	

SEAT CORDOBA

I.0	999	N	AER	09/96	06/99		12283	
I.0	999	N	ANV - ALD	07/99			12283	Hasta Up to chassis M037797
I.4 i	1390	N	AEX-AKV-ANX-APQ	09/96			12283	
I.4 16v	1390	N	APE-AQQ-AUA-AUB	10/99		12438 12440	12549 12550	
I.6 i	1598	N	AEE - ALM	06/94			12283	
I.6 i	1598	N	IF-AFT	02/93	06/99		1805	
I.8 i		N	ABS - ADZ - ACC	02/93	06/99		1805	
I.8 16v	1781	N	ADL	10/93	08/99		1129	
I.8T 20v	1781	N	AQX - AYP	07/99		12242 12478	12476	
2.0	1984	N	AGG	02/93	06/99		1805	
2.0 i	1984	N	2E - AGG	02/93	06/99		1805	
I.9 D	1896	D	IY-AAZ	02/93	08/96		1806	Hasta motor Up to engine 552765
I.9 D	1896	D	IY-AAZ	02/93	08/96		1104	Desde motor From engine 552766
I.9 D	1896	D	AEF	08/96	08/99		1104	
I.9TD	1896	D	IY-AAZ	02/93	08/96		1806	Hasta motor Up to engine 552765

CÓDIGO CODE	EM	CÓDIGO ORIGINAL ORIGINAL CODE	CÓDIGO CODE	EM	CÓDIGO ORIGINAL ORIGINAL CODE	CÓDIGO CODE	EM	CÓDIGO ORIGINAL ORIGINAL CODE
1157	06A109479A=06A109479B=06A109479C		1805	026109243A=026109243E		1806	068109243C	
12242	06B109477		12283	030109243V=030109243K		12438	036109244D	
12440	036109181A		12458	038109243M		12474	038109244J	
12476	058109243D		12478	06B109244		12548	028109243G	
12549	036109243E=036109243L=036109243R=036109243AB		12550	036109243S				

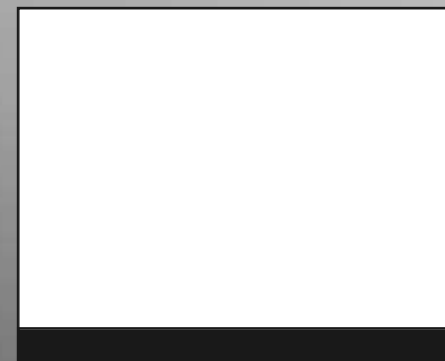
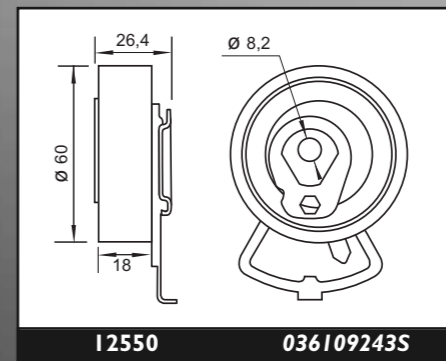
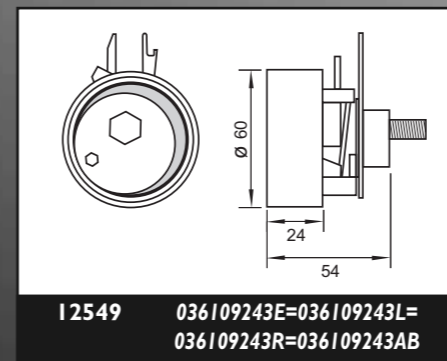
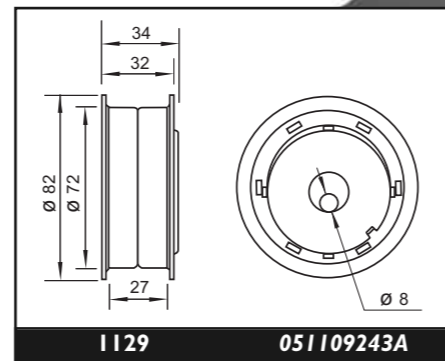
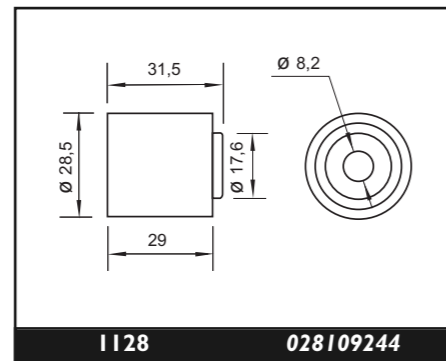
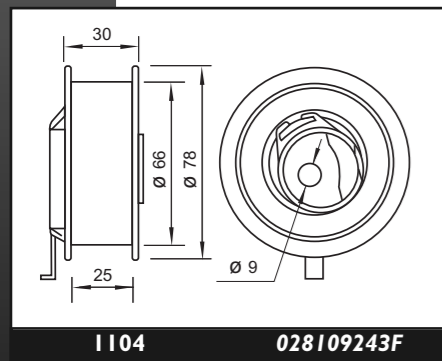

SEAT

SEAT

MODELO MODEL	AÑO YEAR	MOTOR ENGINE	CÓDIGO CODE		FIJO FIXED	MÓVIL MOBILE	NOTA NOTE
			DESDE SINCE	HASTA TO			

SEAT CORDOBA

I.9 TD	1896	D	IY-AAZ	02/93	08/96		1104	Desde motor From engine 552766
I.9 SDi	1896	D	AEY	08/96	06/99		1806	Hasta motor Up to engine 552765
I.9 SDi	1896	D	AEY	08/96	06/99	1128	1104	Desde motor From engine 552766
I.9 SDi	1896	D	IZ-AHU-AFN-ALE	08/96	06/99		1806	Hasta motor Up to engine 552765
I.9 SDi	1896	D	IZ-AHU-AFN-ALE	08/96	06/99	1128	1104	Desde motor From engine 552766
I.9 SDi	1896	D	AGP-AQM	07/99			1166 1131 1167	
I.9 TDi	1896	D	AGR-ALH - ASV	06/99			1166 1131 1167	

SEAT CORDOBA VARIO

I.0	999	N	AER	09/96	06/99		12283	
I.0	999	N	ANV - ALD	07/99			12283	
I.0	999	N	AUC	07/99			12283	
I.4i	1390	N	AEX-AKV-ANX-APQ	09/96			12283	
I.4i	1390	N	AKK - ANW - AUD	07/99			12283	
I.4 16v	1390	N	APE-AQQ-AUA-AUB	10/99		12438 12440	12549 12550	
I.6i	1598	N	AEE - ALM	06/94			12283	
I.9SDi	1896	D	AGP-AQM	07/99			1166 1131 1167	1107
I.9 TDi	1896	D	AGR - ALH - ASV	06/99			1166 1131 1167	1107

SEAT IBIZA II

I.0 i	999	N	AER	09/96	08/99		12283	
I.4 i	1391	N	AEX-ANX-AKV-APQ	09/93	08/99		12283	

CÓDIGO CODE	EM	CÓDIGO ORIGINAL ORIGINAL CODE	CÓDIGO CODE	EM	CÓDIGO ORIGINAL ORIGINAL CODE	CÓDIGO CODE	EM	CÓDIGO ORIGINAL ORIGINAL CODE
1104		028109243F	1107		038109243G=038109243N	1128		028109244=068109243C
1131		058109244	1166		038109244H	1167		038109244E
1806		068109243C	12283		030109243V=030109243K	12438		036109244D
12440		036109181A	12549		036109243E=036109243L= 036109243R=036109243AB	12550		036109243S

MODELO MODEL	COMB./ FUEL	MOTOR ENGINE	AÑO YEAR		CÓDIGO CODE EM euromotor®		
			DESDE SINCE	HASTA TO	FIJO FIXED	MÓVIL MOBILE	NOTA NOTE

SEAT IBIZA II

1.6i	1598	N	AFT - I F	02/93	08/99		1805	
1.8i	1781	N	ABS - ACC - ADZ				1805	
1.8 16v	1781	N	ADL	11/93	08/96		1129	
2.0i	1984	N	2E - AGG	02/93	06/99		1805	
2.0i	1984	N	AGG	03/93	08/99		1805	
2.0i 16v	1984	N	ABF	08/96	08/99		1129	
1.9 D	1896	D	IY	04/93	08/96		1806	Hasta motor Up to engine 378364
1.9 D	1896	D	IY	04/93	08/96		1104	Desde motor From engine 378365
1.9 D	1896	D	AEF	08/96	08/99		1104	
1.9 TD	1896	D	AAZ	03/93			1806	Hasta motor Up to engine 378364
1.9 TD	1896	D	AAZ	03/93		1128	1104	Desde motor From engine 378365
1.9 SDi	1896	D	AEY	08/96	08/99	1128	1104	
1.9 TDi	1896	D	IZ-AHU-AFN-ALE	08/96	08/99	1128	1104	

SEAT IBIZA III

1.0i	999	N	ANV - ALD - AVC	09/99			12283	
1.4 i	1391	N	AKK - ANW - AUD	08/99			12483	
1.4 16v	1390	N	APE - AQQ - AUA - AUB - BBY	10/99		12438 12440	12549 12550	
1.6	1598	N		08/99	04/02		12283	
1.8 T 20v	1781	N	AQX - AYP	11/93	08/96	1131 12478	12240 12242	

CÓDIGO CODE EM	CÓDIGO ORIGINAL ORIGINAL CODE	CÓDIGO CODE EM	CÓDIGO ORIGINAL ORIGINAL CODE	CÓDIGO CODE EM	CÓDIGO ORIGINAL ORIGINAL CODE
	1104	028109243F		1128	028109244=068109243C
	1129	051109243A		1805	026109243A=026109243E
	1806	068109243C		12240	06B109243D
	12242	06B109477		12283	030109243V=030109243K
	12438	036109244D		12440	036109181A
	12478	06B109244		12550	036109243S
	12549	036109243E=036109243L=036109243R=036109243AB			

MODELO MODEL	COMB./FUEL	MOTOR ENGINE	AÑO YEAR		CÓDIGO CODE EM euromotor®		
			DESDE SINCE	HASTA TO	FIJO FIXED	MÓVIL MOBILE	NOTA NOTE

SEAT IBIZA III

I.9 SDi	1896	D	AGP	08/99		1166 1131 1167	1107	
I.9 SDi	1896	D	AQM-AGR-ALH-ASV	08/99		1166 1131 1167	1107	
I.9 TDi	1896	D	ATD-ASZ	01/00	05/01	12238	12239	
I.9 TDi	1896	D	ATD-ASZ	06/01		12474	12458	(130 CV)

SEAT IBIZA IV

I.4 16v	1390	N	BBY-AUB-BBZ			12438 12440	12549 12550	
I.4 TDI	1422	D	AMF			12238	12239	
I.9 TDi	1896	D	ATD-ASZ	01/00	05/01	12238	12239	
I.9 TDi	1896	D	ATD-ASZ	06/01		12474	12458	(130 cv)

SEAT INCA

I.4	1391	N	AEX - AKV - APQ	11/95			12283	
I.4	1391	N	AUD	11/99			12283	
I.4 16v	1391	N	AUA	04/00		12438 12440	12549 12550	
I.6	1598	N	AEE	11/95	05/98		12283	
I.6	1598	N	IF	11/95	05/98		1805	
I.7 D	1714	D	AHB	09/96		1128	1104	
I.9 D	1896	D	IY	11/95		1128	1104	
I.9 SDi	1896	D	AEY			1128	1104	

CÓDIGO CODE EM	CÓDIGO ORIGINAL ORIGINAL CODE	CÓDIGO CODE EM	CÓDIGO ORIGINAL ORIGINAL CODE	CÓDIGO CODE EM	CÓDIGO ORIGINAL ORIGINAL CODE
-------------------	----------------------------------	-------------------	----------------------------------	-------------------	----------------------------------

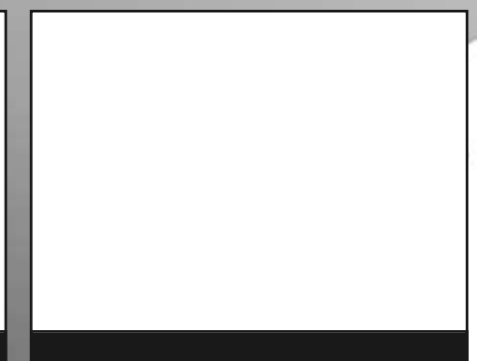
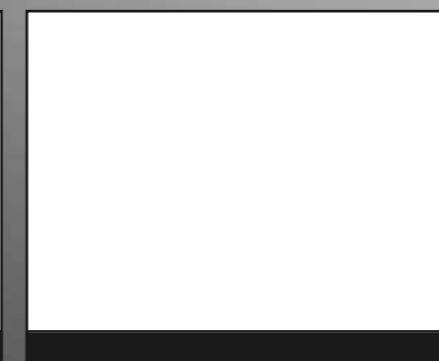
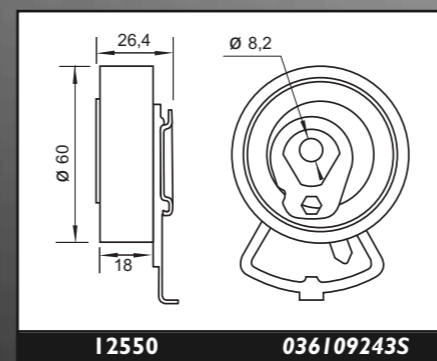
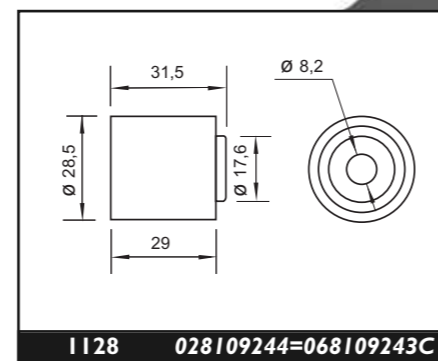
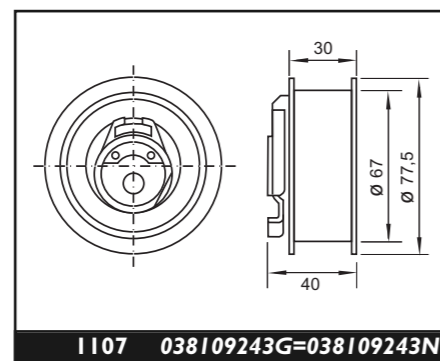
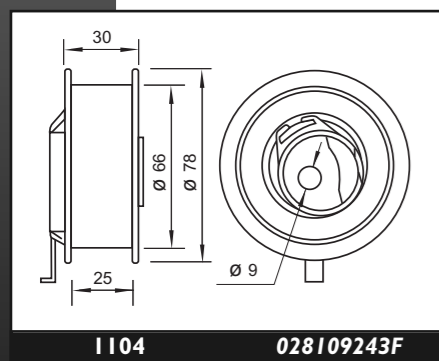
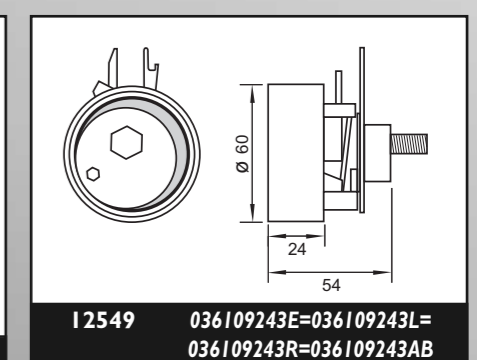
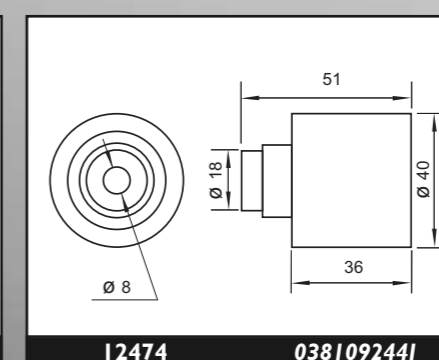
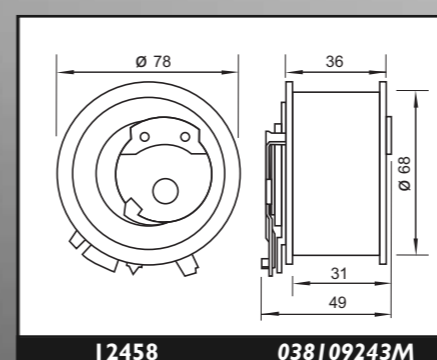
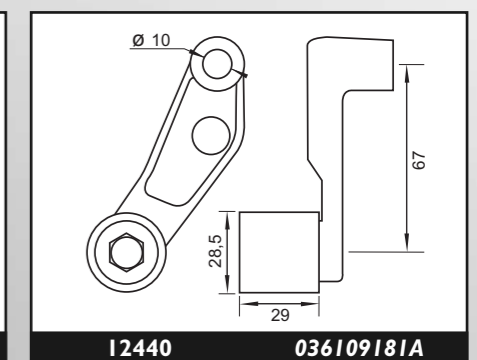
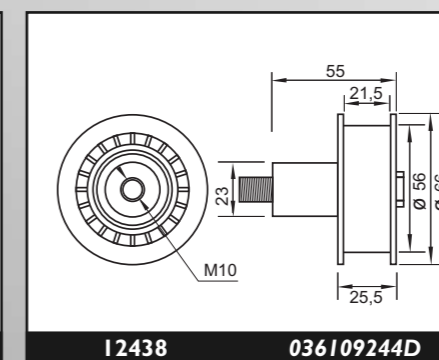
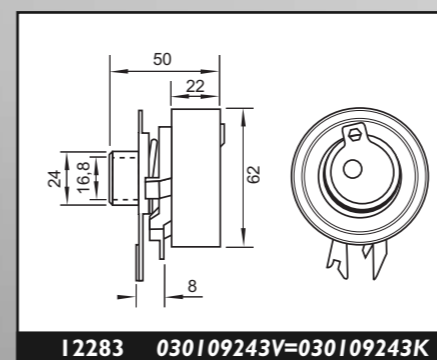
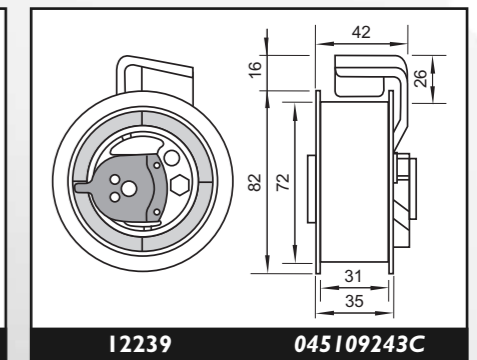
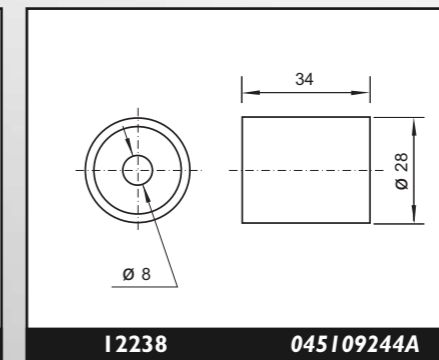
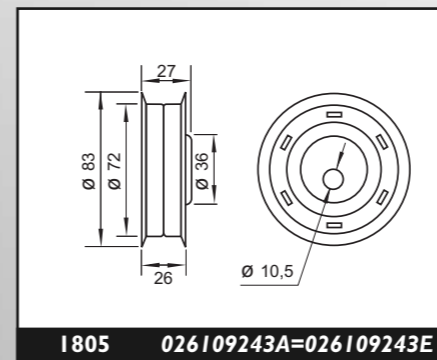
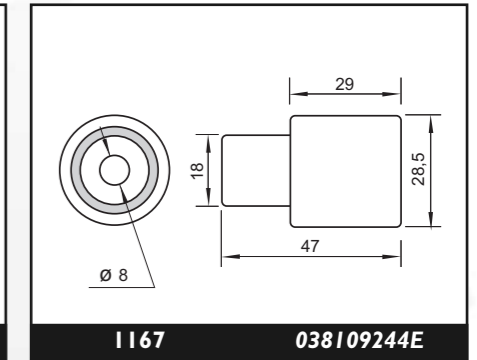
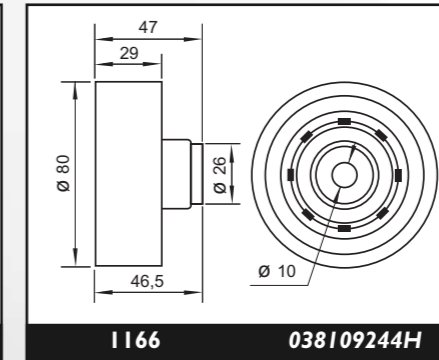
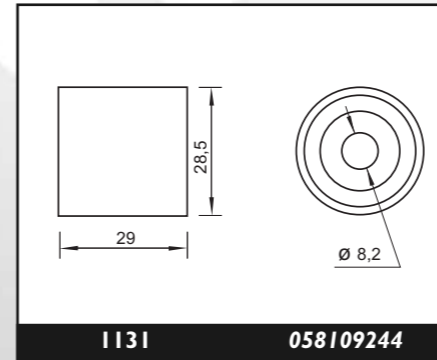

MODELO MODEL	COMB./FUEL	MOTOR ENGINE	AÑO YEAR		CÓDIGO CODE		
			DESDE SINCE	HASTA TO	FIJO FIXED	MÓVIL MOBILE	NOTA NOTE

SEAT INCA

1.9 SDi	1896	D	AYQ	11/95		1166 1167 1131	1107	
---------	------	---	-----	-------	--	----------------------	------	--

SEAT LEON

1.4 16v	1390	N	AHW-APE-AXP-BCA	11/99		12438 12440	12549 12550	
1.6 16v	1598	N	ATN-AUS-AZD-BCB	09/00		12438 12440	12549 12550	
1.8 20v	1781	N	AGN - APG	11/99		1131 12478	12240 12242	
1.8T 20v	1781	N	APP - AUQ			12478	12240 12242	
1.8 20v T4	1781	N	ARY - AJQ			12478	12240 12242	
1.9 SDi	1896	D	AQM	11/99		1166 1131 1167	1107	
1.9TDi	1896	D	AGR - AHF - ALH	11/99		1166 1167 1131	1107	
1.9TDi	1896	D	ASV	11/99		1166 1131 1167	1107	
1.9TDi	1896	D	ARL	01/01		12238	12239	(150 cv)

SEAT RONDA

1.6	1592	N	138 AR.6000	08/83	09/85	1852		
1.6	1592	N	022 A. 1000	08/83	09/85	12500		

CÓDIGO CODE	EM	CÓDIGO ORIGINAL ORIGINAL CODE	CÓDIGO CODE	EM	CÓDIGO ORIGINAL ORIGINAL CODE	CÓDIGO CODE	EM	CÓDIGO ORIGINAL ORIGINAL CODE
1107	038109243G=038109243N		1131	058109244		1166	038109244H	
1167	038109244E		1852	4443446		12238	045109244A	
12239	045109243C		12240	06B109243D		12242	06B109477	
12438	036109244D		12440	036109181A		12478	06B109244	
12500	4443703		12549	036109243E=036109243L= 036109243R=036109243AB		12550	036109243S	

SEAT

SEAT

MODELO MODEL	COMB./FUEL	MOTOR ENGINE	AÑO YEAR		CÓDIGO CODE EM euromotor®		
			DESDE SINCE	HASTA TO	FIJO FIXED	MÓVIL MOBILE	NOTA NOTE

SEAT TOLEDO

1.6	1598	N	IF - EZ - ABN	05/91	03/99	12438	12283	
1.6	1595	N	AEH - AKL	11/96			1157	
1.6	1595	N	AZD	10/99		12438	12549	
1.6i 16v	1595	N	AUS - AZD - BCB	09/00		12438 12440	12549 12550	
1.6i	1595	N	RP-ABS-ADZ-ACC	05/91	12/96			1805
1.8 20v	1781	N	AGN - APG - APP - AUQ - ARY - AJQ	11/99		12242 12478	12240	
2.0i	1984	N	AGG-2E	05/91	12/96			1805
2.0i 16v	1984	N	ABF - ADL	11/93	03/99			1129
1.9 D	1896	D	IY-AAZ	05/91	03/99			1806
								Hasta motor Up to engine 705902
1.9 D	1896	D	IY-AAZ-AFN	05/91	03/99	1128	1104	Desde motor From engine 705903
1.9 SDi	1896	D	AQM	11/99		1166 1131 1167	1107	
1.9 TDi	1896	D	AGR - AHF - ALH - ASV	11/99		1166 1131 1167	1107	
1.9 TDi	1896	D	ARL	10/00		12238	12239	

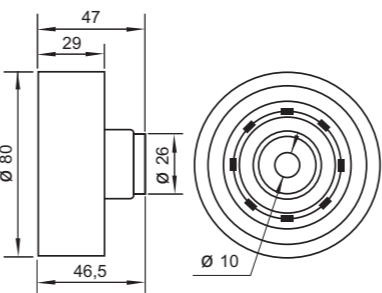
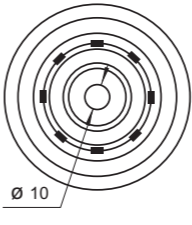
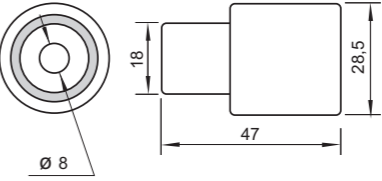
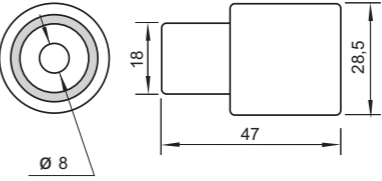
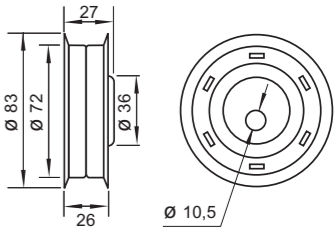
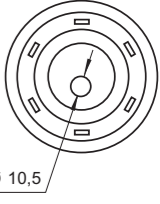
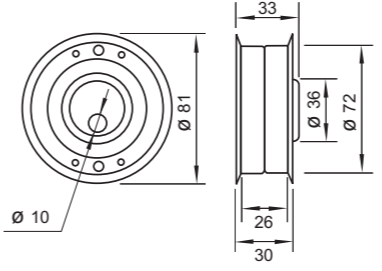
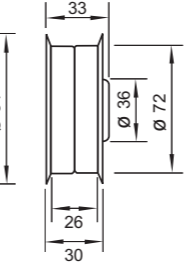
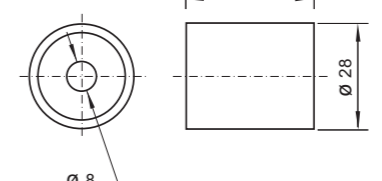
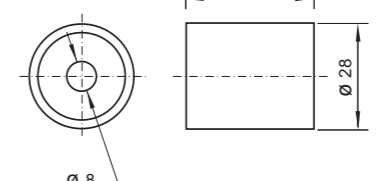
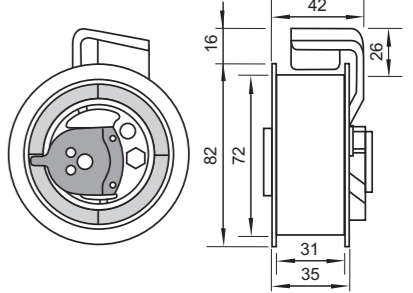
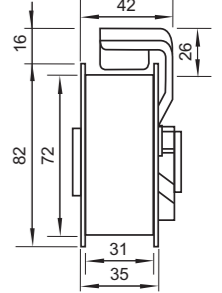
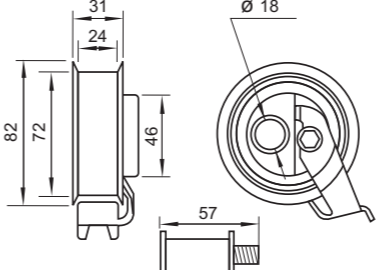
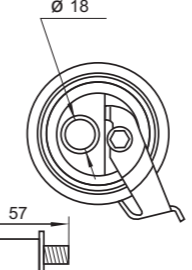
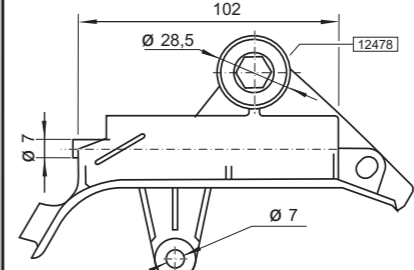
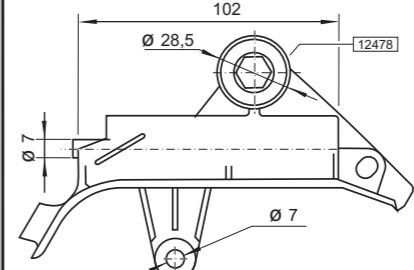
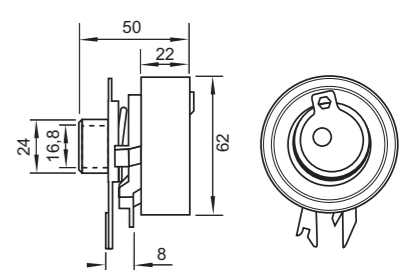
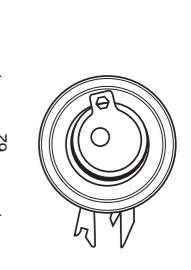
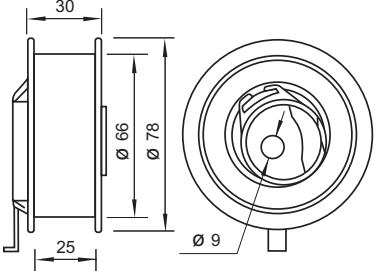
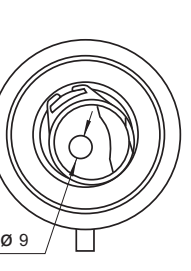
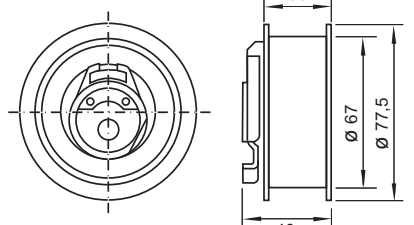
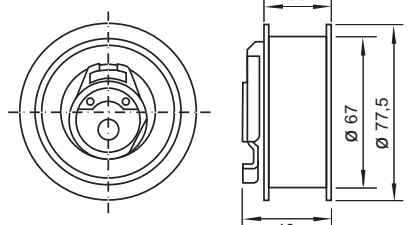
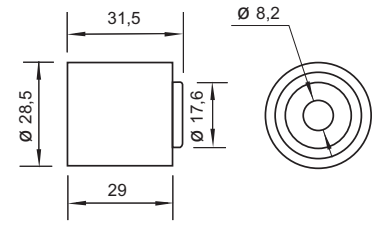
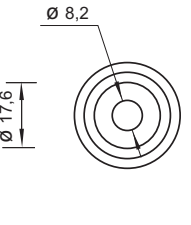
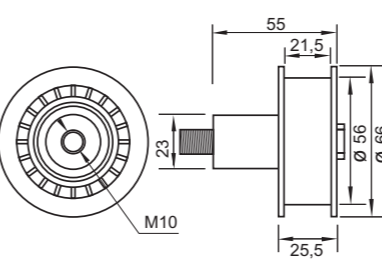
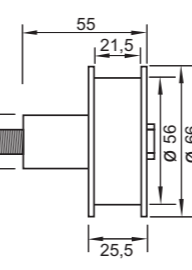
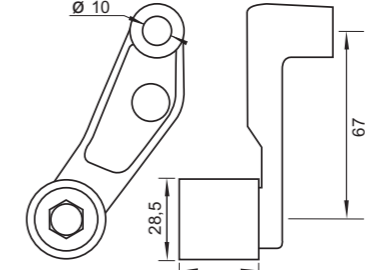
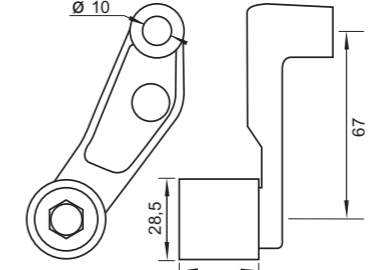
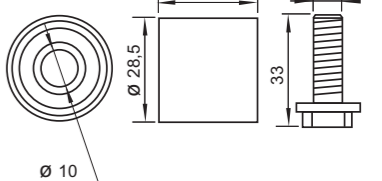
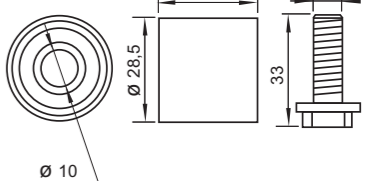
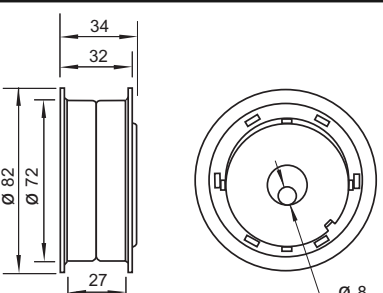
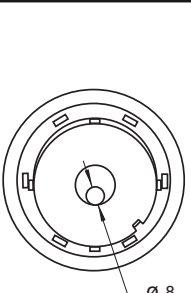
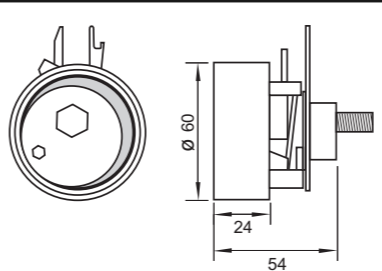
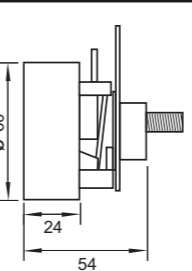
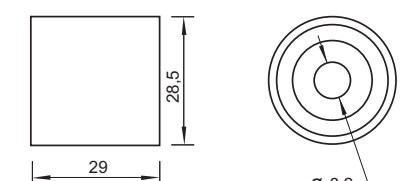
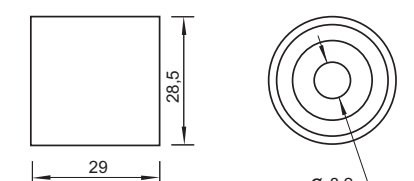
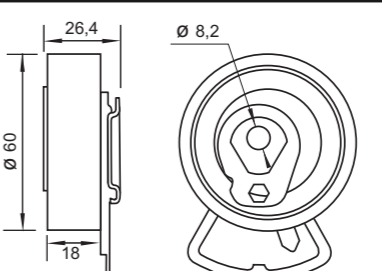
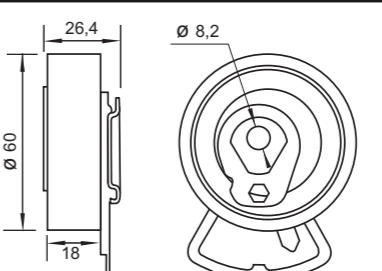
CÓDIGO CODE EM	CÓDIGO ORIGINAL ORIGINAL CODE	CÓDIGO CODE EM	CÓDIGO ORIGINAL ORIGINAL CODE	CÓDIGO CODE EM	CÓDIGO ORIGINAL ORIGINAL CODE
	1166		038109244H		1167
					038109244E
	1805		026109243A=026109243E		
	1806		068109243C		12238
					045109244A
	12239		045109243C		
	12240		06B109243D		12242
					06B109477
	12283		030109243V=030109243K		
	1104		028109243F		1107
					038109243G=038109243N
	1128		028109244=068109243C		12438
					036109244D
	12440		036109181A		12478
					06B109244
	1129		051109243A		12549
					036109243E=036109243L= 036109243R=036109243AB
	1131		058109244		12550
					036109246K=036109243F

EM euromotor[®]

VERSION PDF 2010

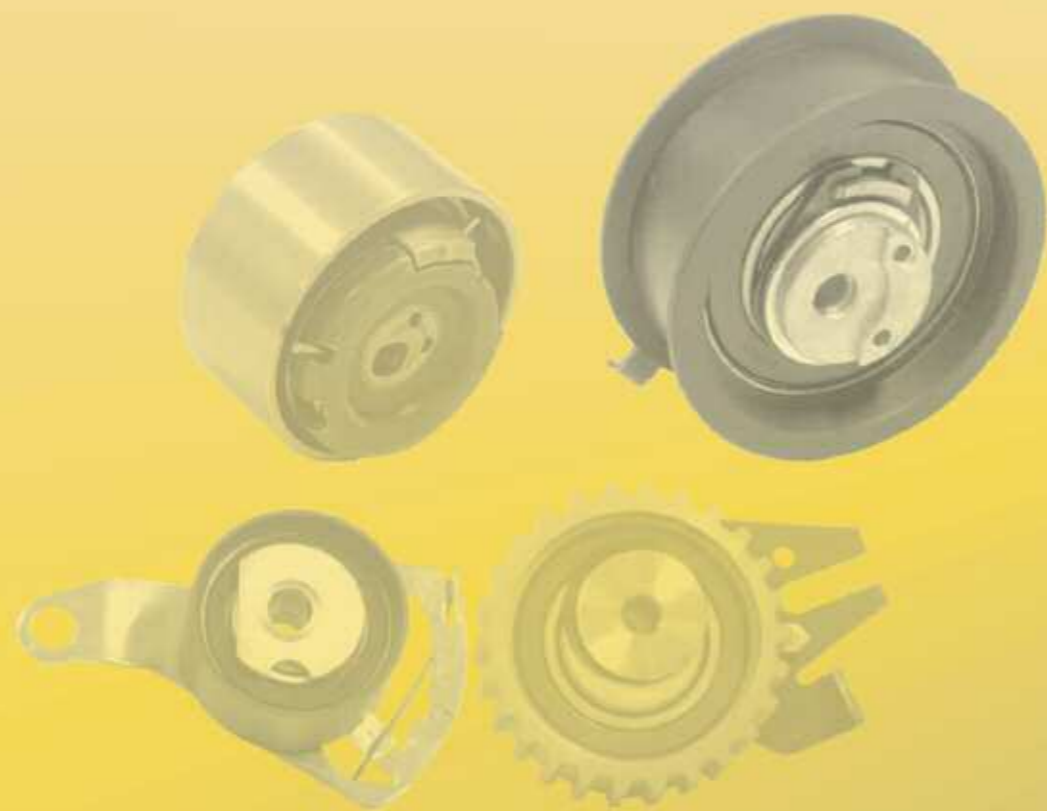

Ø18



SKODA



MODELO MODEL	COMB./FUEL	MOTOR ENGINE	AÑO YEAR		CÓDIGO CODE EM euromotor®		
			DESDE SINCE	HASTA TO	FIJO FIXED	MÓVIL MOBILE	NOTA NOTE

SKODA FABIA

1.4 16v	1390	N	AUA - AUB	07/99		12438 12440	12549 12550
2.0	1984	N	AZL	11/00			1157
1.9 SDi	1896	D	ASY	09/00		1166 1131 1167	1107
1.9TDi	1896	D	ATD	09/00		12238	12239
1.9TDi RS	1896	D		10/03		12238	12239

SKODA FELICIA

1.6	1598	N	AEE	02/97			12283
-----	------	---	-----	-------	--	--	-------

SKODA OCTAVIA

1.4 16v	1390	N	AXP - BCA	07/00		12438 12440	12549 12550
1.6	1595	N	AEE-	09/96	09/00		12283
1.6	1595	N	AEH - AKLAVU-	02/97			1157
1.8 20v	1781	N	AGN	09/96		1131	12240 12242
1.8 20v	1781	N	AGU - ARZ ARX - AUM - AUQ	09/96		12478	12240 12242
2.0	1984	N	AZH - AEG	09/96	03/99		1157
2.0	1984	N	AQY - APK	04/99			1157
2.0	1984	N	AZM	02/00			1157
1.9 SDi	1896	D	AEY	09/96		1128	1104

CÓDIGO CODE EM	CÓDIGO ORIGINAL ORIGINAL CODE	CÓDIGO CODE EM	CÓDIGO ORIGINAL ORIGINAL CODE	CÓDIGO CODE EM	CÓDIGO ORIGINAL ORIGINAL CODE
-------------------	----------------------------------	-------------------	----------------------------------	-------------------	----------------------------------

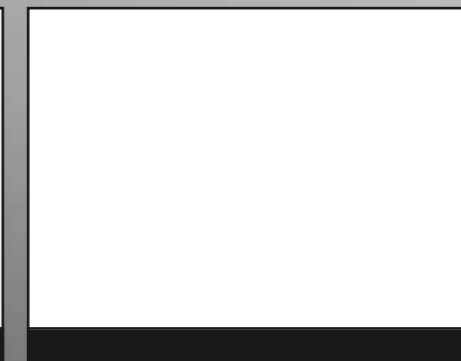
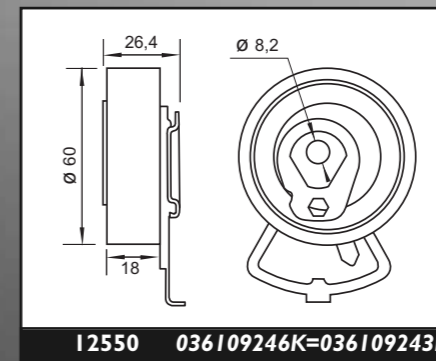
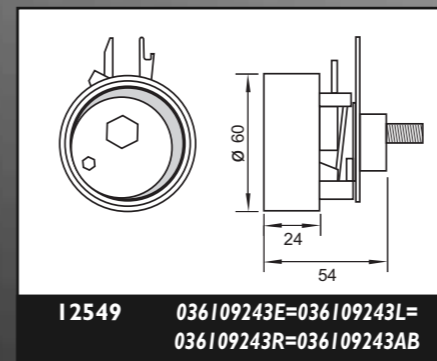
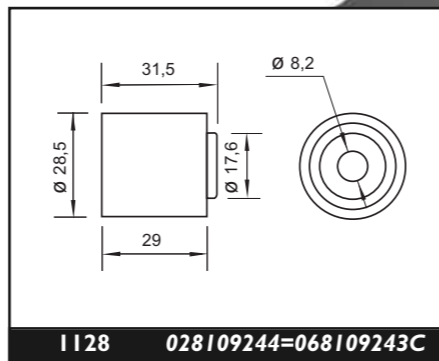
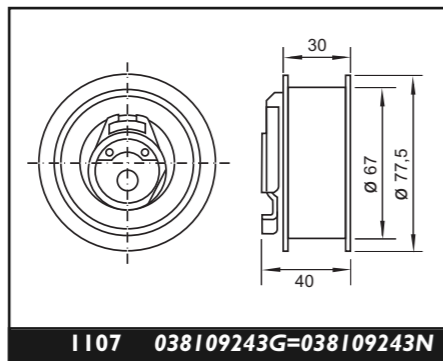
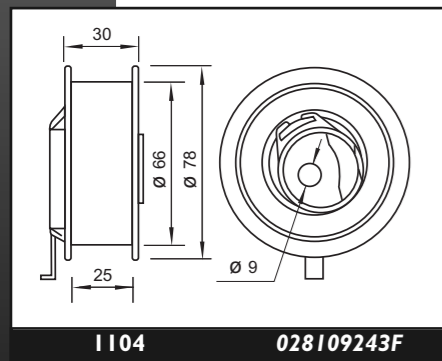
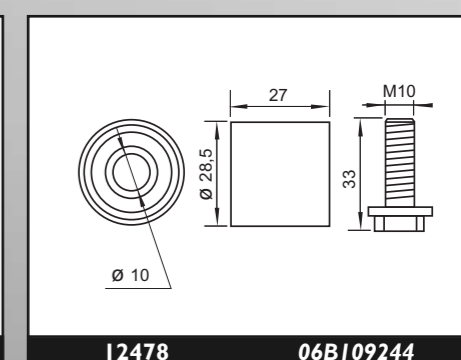
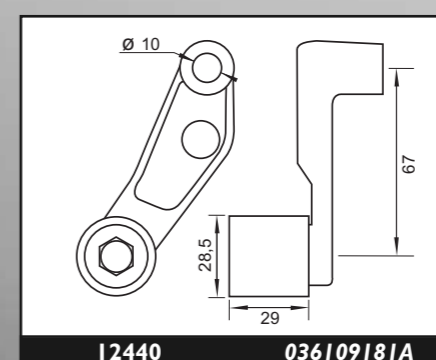
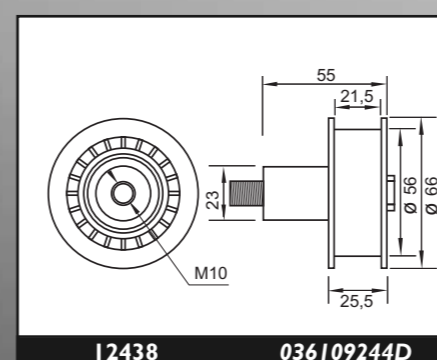
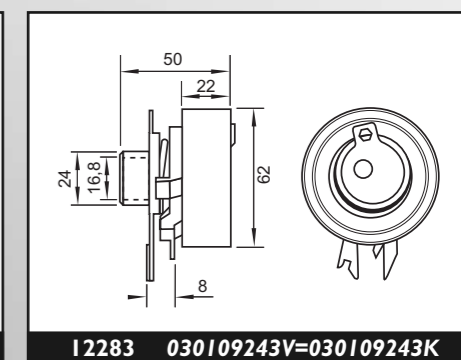
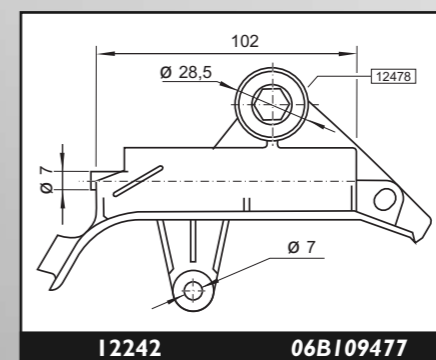
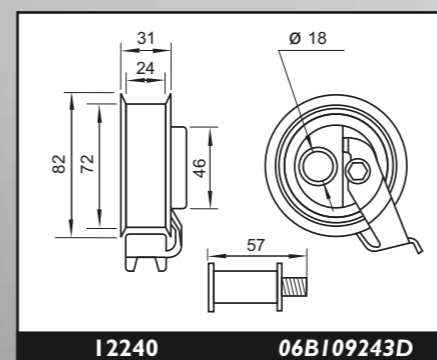
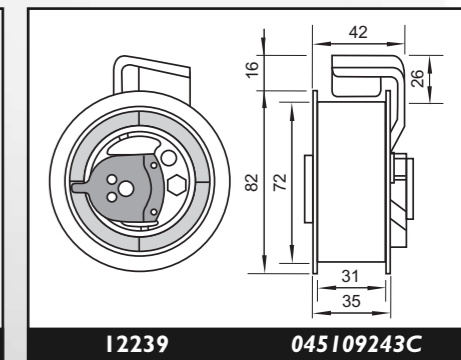
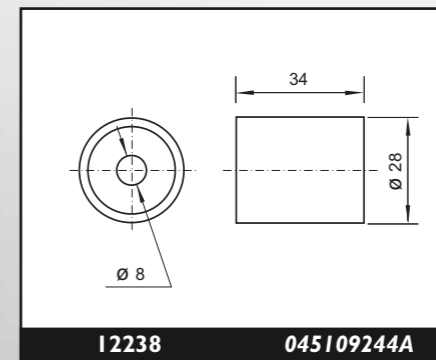
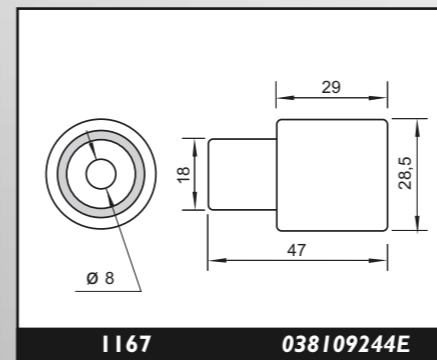
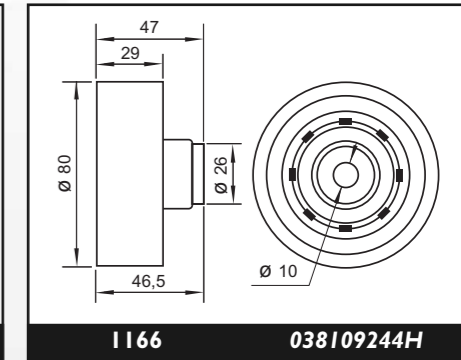
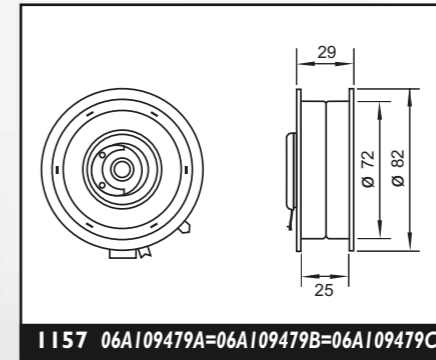
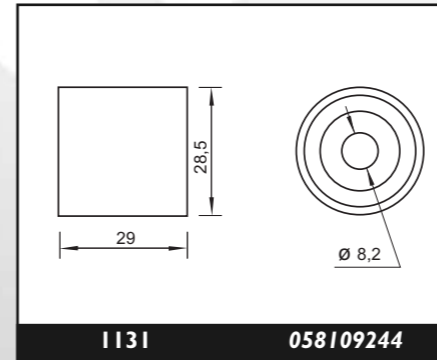

MODELO MODEL	G	COMB./ FUEL	MOTOR ENGINE	AÑO YEAR		CÓDIGO CODE		
				DESDE SINCE	HASTA TO	FIJO FIXED	MÓVIL MOBILE	NOTA NOTE

SKODA OCTAVIA

1.9 SDi	1896	D	AGP - AQM	06/97		1167 1131 1166	1107	
1.9 SDi	1896	D	AGR - AHF	09/96		1166 1131 1167	1107	
1.9 TDi	1896	D	ALH - ASV	09/96		1166 1131 1167	1107	
1.9 TDi	1896	D	ATD	09/00		12238	12239	
1.9 TDi	1896	D	AJZ	09/00		12474	12458	
1.9 TDi	1896	D		12/02		12238	12239	

SKODA OCTAVIA SUPERB

2.0	1984	N	AZM	02/02			1157	
2.8 V6	2771	N	AMX-BBG	02/02		12479	12480	
1.9 TDi	1896	D	AWX-AVB	02/02		12238	12239	

CÓDIGO CODE	EM	CÓDIGO ORIGINAL ORIGINAL CODE	CÓDIGO CODE	EM	CÓDIGO ORIGINAL ORIGINAL CODE	CÓDIGO CODE	EM	CÓDIGO ORIGINAL ORIGINAL CODE
1107		038109243G=038109243N	1131		058109244	1157		06A109479A=06A109479B=06A109479C
1166		038109244H	1167		038109244E	12238		045109244A
12239		045109243C	12458		038109243M	12474		038109244J
12479		078109244H	12480		078109243Q			

EM euromotor®

VERSION PDF 2010



$\varnothing 18$

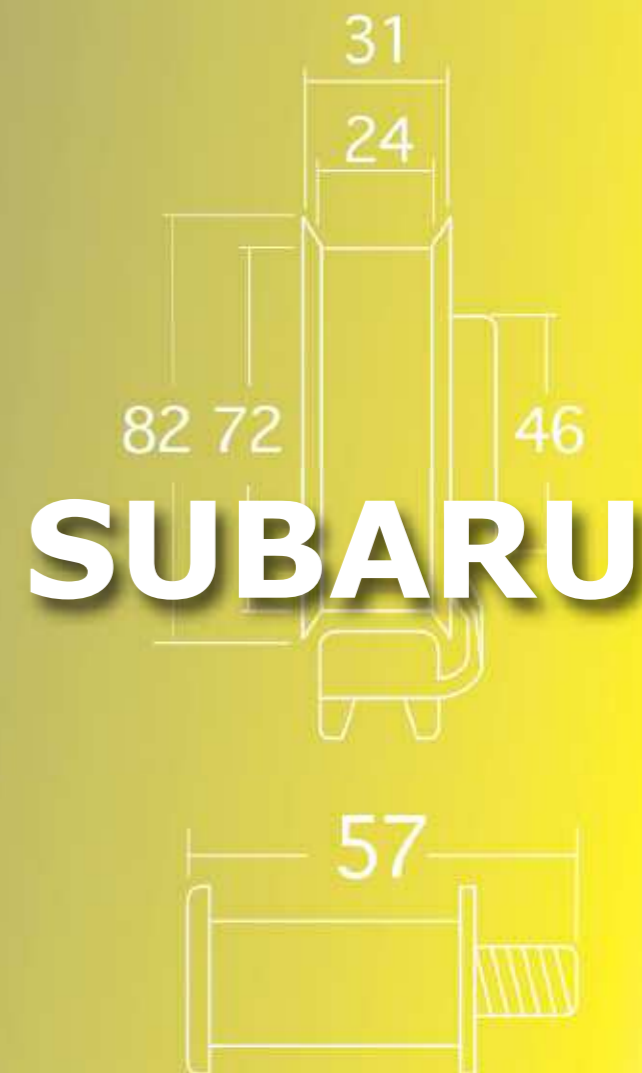

MODELO MODEL	AÑO YEAR	MOTOR ENGINE	CÓDIGO CODE		FIJO FIXED	MÓVIL MOBILE	NOTA NOTE
			DESDE SINCE	HASTA TO			

SUBARU FORESTER

2.0 T	1994	N		08/97	03/98	12236 12236 12237		
2.0 T	1994	N		04/98	08/02	12237 12236 12554		
2.0	1994	N		09/02		12236 12236 12237 12554		
2.0 T	1994	N	EJ20T	08/87	11/00	12236 12236 12554		
2.5 T	2457	N	EJ20T	12/00		12236 12236 12237 12554		

SUBARU IMPREZA

1.6	1597	N	EJ16 -	08/92	01/97	12236 12236 12237	12225	
1.6	1597	N	EJ16-	02/97		12236 12237 12554		
1.8	1800	N	EJ18-	08/92	01/97	12237 12236 12236	12225	
1.8	1800	N	EJ18E -	02/97	12/97	12237 12236 12554		
2.0	1994	N	EJ20-	03/94	01/97	12236 12236 12237	12225	
2.0	1994	N	EJ20-	02/97	12/97	12236 12237 12554		
2.0 T	1994	N	EJ20T	03/94	10/98	12236 12236 12237 12554		
2.0 WRXT	1994	N		08/00		12236 12236 12237 12554		GD - GG GDB

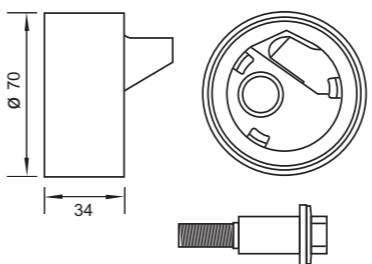
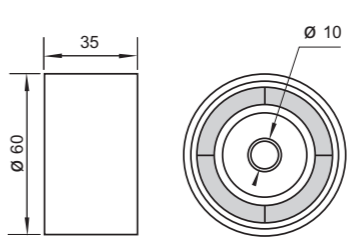
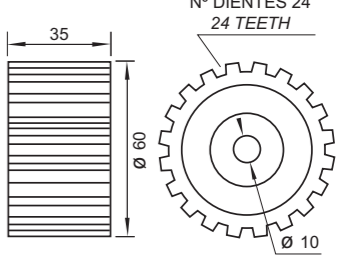
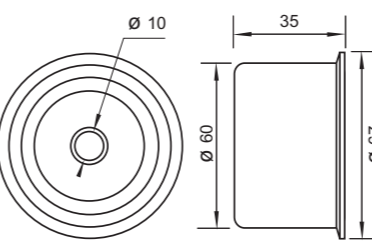
CÓDIGO CODE	EM	CÓDIGO ORIGINAL ORIGINAL CODE	CÓDIGO CODE	EM	CÓDIGO ORIGINAL ORIGINAL CODE	CÓDIGO CODE	EM	CÓDIGO ORIGINAL ORIGINAL CODE
								
12225		13069 AA036 - 13069 AA034	12236		13073 AA081 - 13073 AA142	12237		13085 AA010
								
12554		13078 AA190						

MODELO MODEL	COMB./FUEL	MOTOR ENGINE	AÑO YEAR		CÓDIGO CODE			MÓVIL MOBILE	NOTA NOTE
			DESDE SINCE	HASTA TO	FIJO FIXED	EM euromotor®			

SUBARU IMPREZA

2.5 T	2500	N	EJ25I - EJ25IE	01/99	07/05	12236 12236 12237 12554		
-------	------	---	----------------	-------	-------	----------------------------------	--	--

SUBARU JUSTY

1.2	1190	N	EF12-	10/86	10/95		12304	
1.3	1298	N	EF12-	11/95			12304	

SUBARU LEGACY

1.6	1597	N	EJ16A -	01/89	09/91	12236 12236 12237	12225	
1.8	1820	N	EJ18A	01/89	07/94	12236 12236 12237	12225	
2.0	1994	N	EJ20GN	05/92	01/97	12236 12236 12237 12554	12225	
2.2	2000	N	EJ20EMPI	02/97		12236 12236 12237		
2.2	2212	N	EJ22EMPI	01/89		12236 12237 12554	12225	
2.5	2457	N	EJ25D	06/96	09/96	12236 12237 12554		
2.5	2457	N	EJ25D	10/96		12236 12236 12237 12554		

SUBARU LIBERO

1.2	1190	N	EF12	08/86	02/00		12304	
-----	------	---	------	-------	-------	--	-------	--

CÓDIGO CODE	EM	CÓDIGO ORIGINAL ORIGINAL CODE	CÓDIGO CODE	EM	CÓDIGO ORIGINAL ORIGINAL CODE	CÓDIGO CODE	EM	CÓDIGO ORIGINAL ORIGINAL CODE
	12225	13069 AA036 - 13069 AA034		12236	13073 AA081 - 13073 AA142		12237	13085 AA010
	12304	13070 KA020		12554	13078 AA190			

EM euromotor®

VERSION PDF 2010



$\varnothing 18$



MODELO MODEL	COMB./FUEL	MOTOR ENGINE	AÑO YEAR		CÓDIGO CODE		
			DESDE SINCE	HASTA TO	FIJO FIXED	MÓVIL MOBILE	NOTA NOTE

SUZUKI ALTO I

800	796	N	F8B	06/82	12/85		12281	
-----	-----	---	-----	-------	-------	--	-------	--

SUZUKI ALTO II

800	796	N	F8B	01/86	11/93		12281	
-----	-----	---	-----	-------	-------	--	-------	--

SUZUKI ALTO III

1.0	993	N	G10B	12/93	05/02		12229	
-----	-----	---	------	-------	-------	--	-------	--

SUZUKI BALENO

1.3	1298	N		09/96			12229	
1.3 16v	1298	N	G13B	07/95			12230	
1.6 16v	1590	N	G16A - G16B	07/95			12229	
1.9TD	1905	D	XUD9	04/98		1901	1900	

SUZUKI CHEVROLET

1.0	993	N	G10 (SOHC)	1986			12210	
1.0	993	N	G10 (SOHC)	1986			12281	

SUZUKI FUN

FUN	1389	N	X1452	03/04			1948	
-----	------	---	-------	-------	--	--	------	--

SUZUKI IGNIS I

1.3	1328	N		10/00	08/03		12230	
-----	------	---	--	-------	-------	--	-------	--

SUZUKI IGNIS II

1.3	1328	N		08/93			12230	
-----	------	---	--	-------	--	--	-------	--

SUZUKI LIANA

1.6 16v	1586	N		03/02			12229	
1.4 DDis 16v	1461	D		04/04			12298	

SUZUKI SWIFT

1.0TURBO	993	N	G10A	10/83	03/89		12210	
----------	-----	---	------	-------	-------	--	-------	--

CÓDIGO CODE	EM	CÓDIGO ORIGINAL ORIGINAL CODE	CÓDIGO CODE	EM	CÓDIGO ORIGINAL ORIGINAL CODE	CÓDIGO CODE	EM	CÓDIGO ORIGINAL ORIGINAL CODE
1900		12810-86CA0	1901		12830-86CA0	1948		90353176 = 90499401
12210		12810 - 82003	12229		12810-71C02=12810-71C00	12230		12810-53B00=12810-53B01
12281		12810 - 53A00	12298		8200102941			

MODELO MODEL	COMB./FUEL	MOTOR ENGINE	AÑO YEAR		CÓDIGO CODE		
			DESDE SINCE	HASTA TO	FIJO FIXED	MÓVIL MOBILE	NOTA NOTE

SUZUKI SWIFT

1.0	998	N	G10A	04/89	05/96		12231	
1.0	998	N	G10A	06/96			12230	
1.3	1324	N	G13A - G13B	08/86	05/96		12210	
1.3 GTI	1324	N	G13A-G13B-DOHC	08/86	03/98		12231	
1.3	1324	N	G13A - G13B	08/86	03/89		12281	
1.3 16v GTI	1289	N	G13K	04/89			12230	

SUZUKI WAGON R+

1.3 16v	1298	N		05/00			12229	
---------	------	---	--	-------	--	--	-------	--

SUZUKI X-90

1.6 16v	1590	N	G16B	09/95			12229	
---------	------	---	------	-------	--	--	-------	--

SUZUKI CARRY

800	791	N	F8A	11/80	10/85		12281	
1.0	970	N	F10A	10/85	03/99		12281	
1.0	970	N	F10A	1996	03/99		12329	
1.3	1298	N	G13B	04/99			12229	

Todo terreno

SUZUKI JIMNY

1.3 16v	1298	N	G13BB	09/98			12229	
1.5 DDis 4WD	1461	D		04/04			12298	

SUZUKI SAMURAI

SJ 410 1.0	970	N	F10A	09/81			12281	
SJ 413 1.3	1298	N	G13A	11/88	12/92		12210	
SJ 413 1.3	1298	N		01/93			12229	
SJ 413 1.3	1324	N	G13A - G13B	09/81			12210	
1.9TD	1905	D	XUD9	11/98		1901	1900	

CÓDIGO CODE	EM	CÓDIGO ORIGINAL ORIGINAL CODE	CÓDIGO CODE	EM	CÓDIGO ORIGINAL ORIGINAL CODE	CÓDIGO CODE	EM	CÓDIGO ORIGINAL ORIGINAL CODE
1900		12810-86CA0	1901		12830-86CA0	12210		12810-82003
12229		12810-71C02=12810-71C00	12230		12810-53B00=12810-53B01	12231		12810-86500=12810-86501
12281		12810-53A00	12298		8200102941	12329		12810-70802=12810-81401

MODELO MODEL	G	COMB./FUEL	MOTOR ENGINE	AÑO YEAR		CÓDIGO CODE		
				DESDE SINCE	HASTA TO	FIJO FIXED	MÓVIL MOBILE	NOTA NOTE

SUZUKI GRAND VITARA

1.6	1590	N		03/98			12229	
2.0	1995	N		03/98		12187	12183	
2.0TD	1998	D	RF	03/98		12524	12527	
2.0 HDI	1998	D	RHZ-DW10	07/01		12094	12093	

SUZUKI VITARA

1.6	1589	N	G16A - G16M	07/88	01/95		12210	
1.6 16v	1589	N	G16B	07/90	12/99		12329	
2.0	1995	N		12/96		12187	12183	
1.9TD	1905	D	XUD9	01/95		1900	1901	
2.0 HDI	1998	D	RHZ - DW10	03/04		12094	12093	

CÓDIGO CODE	EM	CÓDIGO ORIGINAL ORIGINAL CODE	CÓDIGO CODE	EM	CÓDIGO ORIGINAL ORIGINAL CODE	CÓDIGO CODE	EM	CÓDIGO ORIGINAL ORIGINAL CODE
1900		12810-86CA0	1901		12830-86CA0	12093		12810-67G01
12094		12823-67G01	12183		13505-74011	12187		13503-63011
12210		12810-82003	12229		12810-71C02=12810-71C00	12329		12810-70802=12810-81401
12524		RF7112730A	12527		RF03-12700A			

EM euromotor®

VERSION PDF 2010



$\varnothing 18$

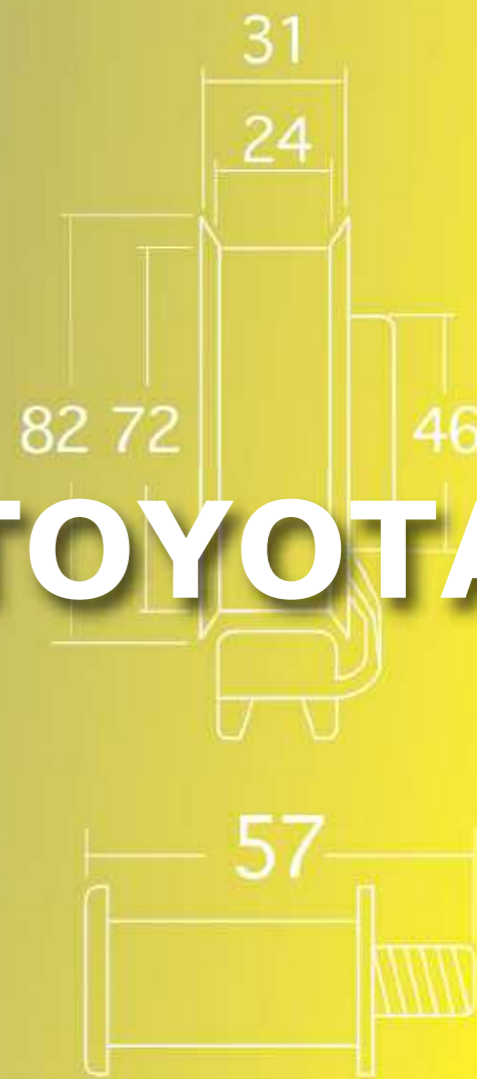

TOYOTA



MODELO MODEL	COMB./FUEL	MOTOR ENGINE	AÑO YEAR		CÓDIGO CODE			NOTA NOTE
			DESDE SINCE	HASTA TO	FIJO FIXED	MÓVIL MOBILE	CÓDIGO ORIGINAL ORIGINAL CODE	

TOYOTA AVENSIS

1.6	1587	N	4A-FE	09/97			12254	
1.8	1762	N	7A-FE	09/97			12254	
2.0	1998	N	3S-FE	09/97		12187	12183	
2.0TD	1975	D	2C-T	09/97		12205	12184	

TOYOTA CAMRY

1.8	1762	N	1SL	03/83	08/88	12187	12186	
2.0 16v	1998	N	2SE	03/83	08/88	12187	12186	
2.0 16v	1998	N	3S-FE	11/86	05/91	12187	12183	
2.2 16v	2198	N	5S-FE	06/91	10/00	12187	12183	
2.5V6	2500	N	2V-ZFE	07/88	06/91	12559	12557	
3.0 24v	2998	N	3V-ZFE - 1M-ZFE	08/96	11/01	12559	12557	
3.0 24v	2998	N	1M ZFE	11/01	06/04	12559		

TOYOTA CARINA

1.5	1500	N	5A-FE	08/92	02/95	12558	12254	
1.5	1500	N	5A-FE	11/92	08/95	12558	12556	
1.6 16v	1587	N	4AFE	10/83	11/87		12216	
1.8	1762	N		10/83	11/87		12216	
1.6 16v	1587	N	4AFE	02/92	09/97		12254 12254	
1.8	1762	N		02/92	09/97		12254 12254	

TOYOTA CARINA E

2.0	1998	N	3S-FE	04/92	09/97	12187	12183	
2.0	1998	N	3S-GE	04/92	09/97	12187	12183	
2.0 D	1975	D	2C - 2C - T	01/96	09/97	12205	12184	
2.0TD	1975	D	2C - 2C - T	01/96	09/97	12205	12184	

CÓDIGO CODE	EM	CÓDIGO ORIGINAL ORIGINAL CODE	CÓDIGO CODE	EM	CÓDIGO ORIGINAL ORIGINAL CODE	CÓDIGO CODE	EM	CÓDIGO ORIGINAL ORIGINAL CODE
12183		13505-74011	12184		13505-64021=13505-64011	12186		13505-63010
12187		13503-63011	12205		13503-64020	12216		13505-15041
12254		13505-15050	12556		13505-11040	12557		13505-20010
12558		13503-11030	12559		13503-62010			

MODELO MODEL	COMB./FUEL	MOTOR ENGINE	AÑO YEAR		CÓDIGO CODE EM euromotor®		
			DESDE SINCE	HASTA TO	FIJO FIXED	MÓVIL MOBILE	NOTA NOTE

TOYOTA CELICA

1.6	1587	N	4A-GE/GEL/GELC	12/83	08/89		12561	
1.6	1587	N	4A-L - 4A-FE	04/86	01/94		12216	
1.6 GT	1587	N	4A-GE/GEL/GELC	12/83	08/89		12561	
1.6 STI	1587	N	4A-L - 4A-FE	04/86	01/94		12216	
1.8 16v	1762	N	7A-FE	11/93	11/99		12254	
2.0 GT	1998	N	3S-GELC - 3S-GEL	09/85	08/89	12187	12562	
2.0	1998	N	3S-GE - 3S-GTE	11/93	11/99	12187	12564	
2.0	1998	N	3S-GE - 3S-GTE	03/88	01/94	12187		
2.0 Turbo	1998	N	3S-GE - 3S-GTE	03/88	01/94	12187		
2.0 Turbo	1998	N	3S-GE - 3S-GTE	11/93	11/99	12187	12564	
2.2	2200	N	5S-FE	09/89	04/96	12187	12183	
2.8 Supra	2759	N	5M-GE	05/82	10/86		12563	

TOYOTA COROLLA

1.3	1299	N	2E-L	06/83	09/84		12216	
1.3	1299	N	2E-L - 2E-LC	05/86	08/87	12340	12560	
1.3	1291	N	2E - 2E-E	08/87	12/92	12340	12560	
1.3	1332	N	2E - 4E-FE	07/92	02/00	12558	12556	
1.6	1587	N	4A-L - 4A-LC	06/83	05/88		12216	
1.6	1587	N	4A-F - 4A-FE	08/87	06/93		12216	
1.6	1587	N	4A-FE	07/92	02/00		12254	
1.6 16v	1587	N	4A - GE/GEL - 4A-GEC	08/85	04/92		12561	
GTI	1587	N	4A - GE/GEL - 4A-GEC	08/85	04/92		12561	
1.8 16v 4WD	1762	N	7A-FE	09/95	02/00		12254	
1.8 D	1839	D	1C- 1C-L	01/83	06/93	12205	12184	
2.0 D	1975	D	2C	07/92	02/00	12205	12184	

CÓDIGO CODE EM	CÓDIGO ORIGINAL ORIGINAL CODE	CÓDIGO CODE EM	CÓDIGO ORIGINAL ORIGINAL CODE	CÓDIGO CODE EM	CÓDIGO ORIGINAL ORIGINAL CODE
	13505-74011		13505-64021=13505-64011		13503-63011
12183		12184		12187	
	13503-64020		13505-15041		13505-15050
12205		12216		12254	
	13503-10011		13505-11040		13503-11030
12340		12556		12558	
	13505-11010=13505-11011=13505-11020		13505-16010=13505-16011=13505-16020=13505-16020		13505-74030
12560		12561		12562	
	13505-43010		13505-88480		
12563		12564			

MODELO MODEL	G	COMB./FUEL	MOTOR ENGINE	AÑO YEAR		CÓDIGO CODE		
				DESDE SINCE	HASTA TO	FIJO FIXED	MÓVIL MOBILE	NOTA NOTE

CÓDIGO CODE	EM	CÓDIGO ORIGINAL ORIGINAL CODE	CÓDIGO CODE	EM	CÓDIGO ORIGINAL ORIGINAL CODE	CÓDIGO CODE	EM	CÓDIGO ORIGINAL ORIGINAL CODE
----------------	----	----------------------------------	----------------	----	----------------------------------	----------------	----	----------------------------------

TOYOTA CORONA

1.5	1500	N	E3	12/87	11/89	12566	12560	
1.6		N		12/87	11/89	12566	12560	
2.0 D	1975	D	2C	10/83	08/95	12205	12184	

TOYOTA CRESSIDA

2.0	1988	N	1G-E	08/82	07/94	12567	12565	
2.0	1988	N	1G-E - 1G-GE	08/84	08/86	12187	12565	
3.0	2959	N	7M-GE	08/88	11/92		12568	
2.4 D	2429	D	2L	08/84	08/89	1989	1988	

TOYOTA CROWN

3.0	2559	N	7M - GE	09/87	10/89		12568	
2.2 D	2429	D	2L	08/83	02/95	1989	1988	

TOYOTA LEXUS

GS300	2997	N	2JZ-GE	03/93		12559	12557	
IS200	1988	N	1G-FE	04/99		12187	12565	
ES 300	2959	N	1MZ-FE 3VZ-FE	09/91	12/97	12559	12557	

TOYOTA MR2

1.6 16v	1587	N	4A-GEL/GELC	11/84	06/90		12561	
2.0 16v	1998	N	3S-GE	12/89	05/00	12187		
2.2	2200	N	5S-FE	12/89	05/00	12187	12183	

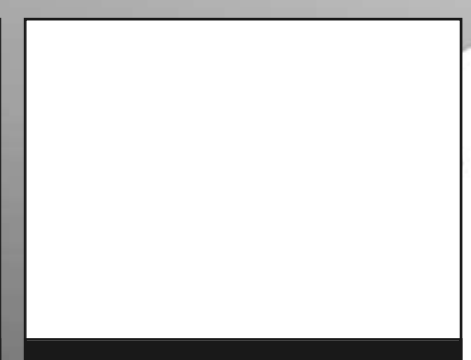
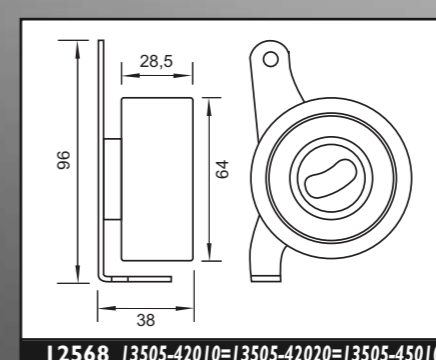
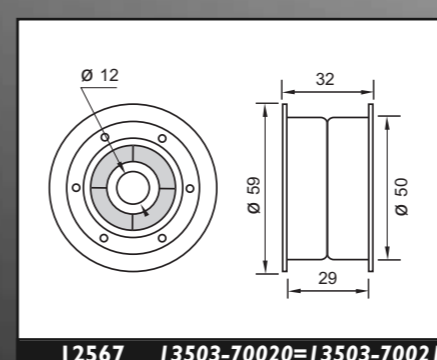
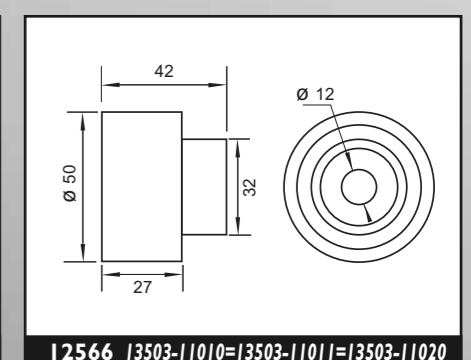
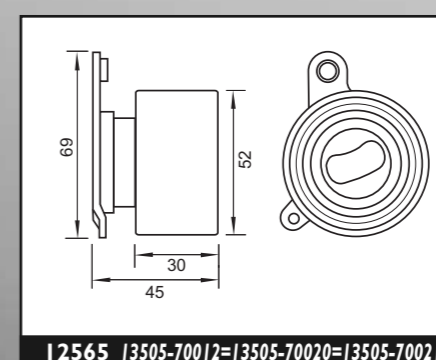
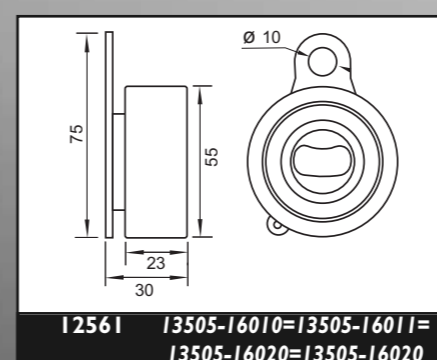
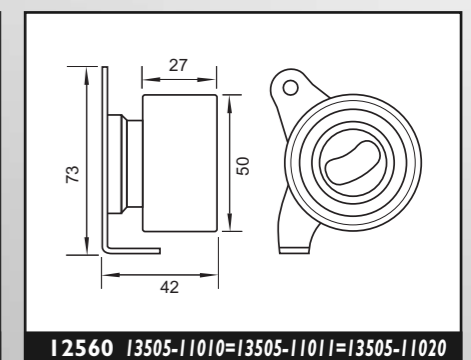
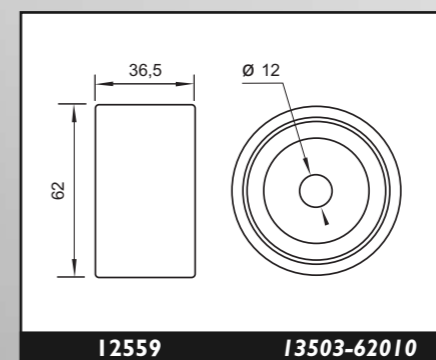
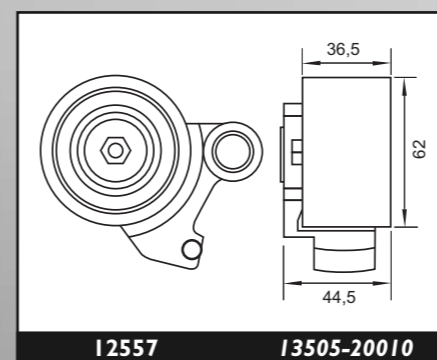
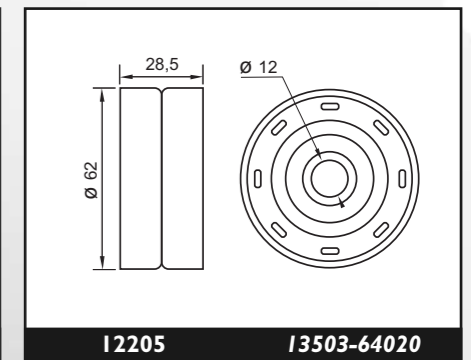
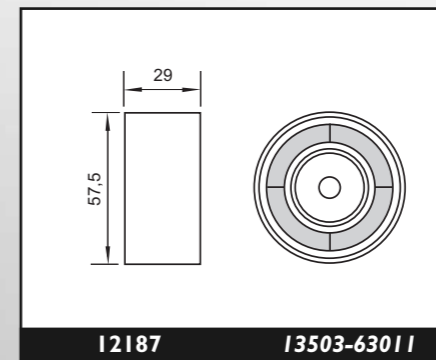
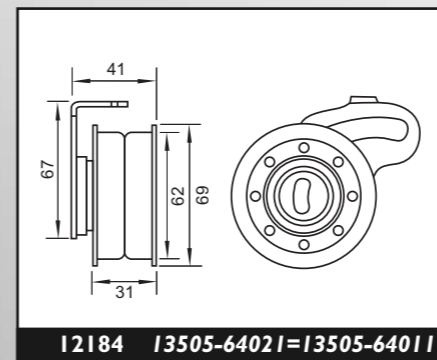
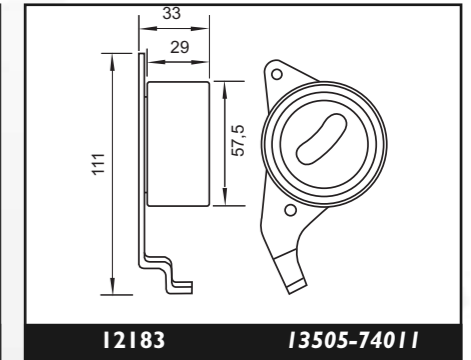
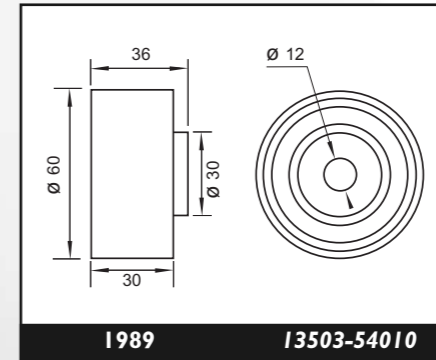
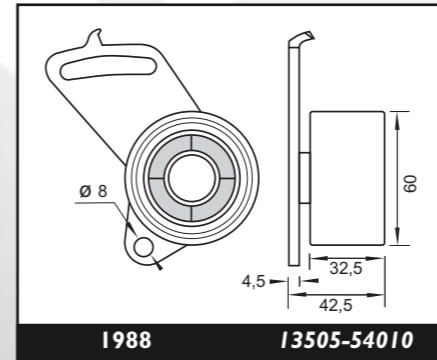

MODELO MODEL	COMB./FUEL	MOTOR ENGINE	AÑO YEAR		CÓDIGO CODE		
			DESDE SINCE	HASTA TO	FIJO FIXED	MÓVIL MOBILE	NOTA NOTE

TOYOTA PASEO

1.5	1497	N	5E-FE	04/96		12558	12556
-----	------	---	-------	-------	--	-------	-------

TOYOTA PIC NIC

2.0 16v	1998	N	3S-FE	05/96		12187	12183
2.2 TD	2184	D	3C-TE	08/97		12205	12184

TOYOTA STARLET

1.3	1296	N	2E-E	01/90	03/96	12558	12556
1.3	1332	N	4E-FE	04/96		12558	12556

Utilitarios

TOYOTA HIACE

2.2 D	2173	D	L	01/79	08/85	1989	1988
2.4 D	2429	D	2L	11/82	08/89	1989	1988
2.4 D	2429	D	2L	08/88		1014	1013
2.4 TD	2446	D	2L-T/TE			1014	1013
2.8 D	2800	D	3L	08/89	09/96	1014	1013
3.0 D	2982	D	1KZ-TE	08/93	02/96		1176

TOYOTA HILUX

2.2 D	2173	D	L	01/79	08/85	1989	1988
2.4 D	2429	D	2L - 2LT - 2LTE	08/89	02/91	1014	1013
2.5 D	2494	D	2KD FTV	09/04			1176
2.5 TD	2494	D	2KD FTV	09/04			1176
2.8 D	2800	D	3L	09/88	02/95	1014	1013
3.0 D	2982	D	1KZ-TE	08/93	02/95		1176
3.0 D	2982	D	1KD FTV	11/04			1176
3.0 TD	2982	D	1KD FTV	11/04			1176

CÓDIGO CODE	EM	CÓDIGO ORIGINAL ORIGINAL CODE	CÓDIGO CODE	EM	CÓDIGO ORIGINAL ORIGINAL CODE	CÓDIGO CODE	EM	CÓDIGO ORIGINAL ORIGINAL CODE
----------------	----	----------------------------------	----------------	----	----------------------------------	----------------	----	----------------------------------

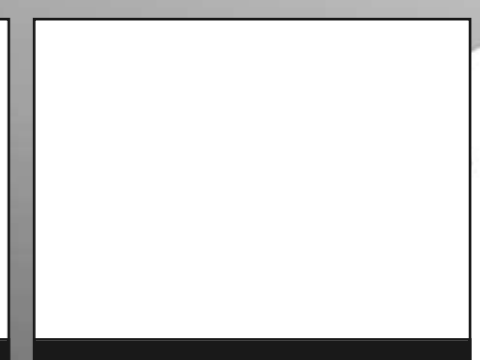
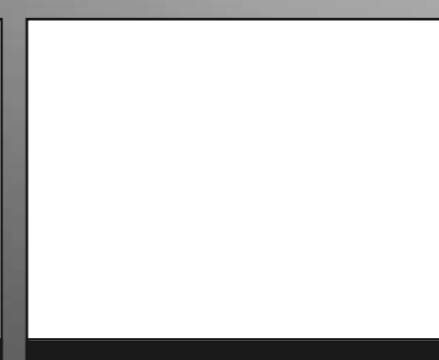
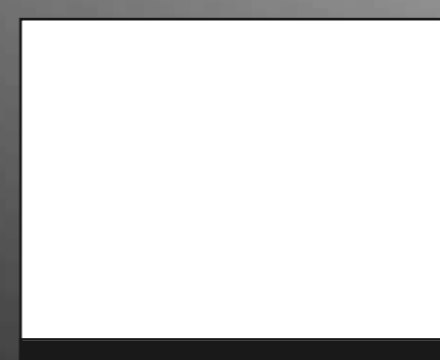
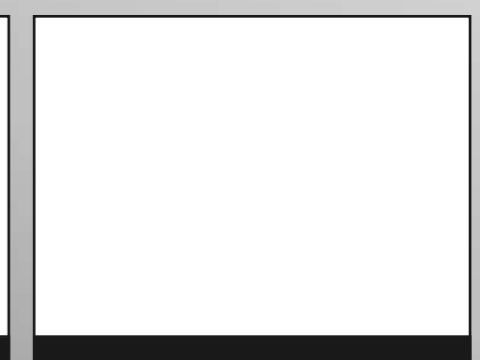
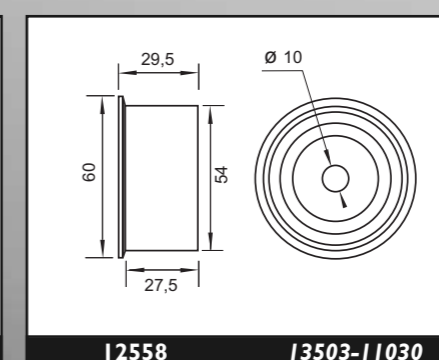
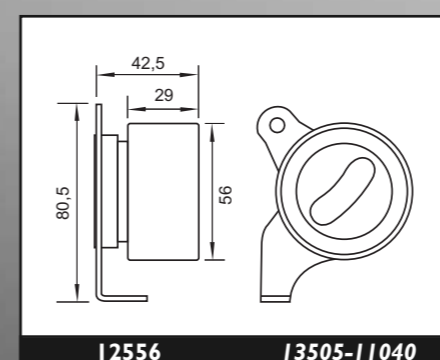
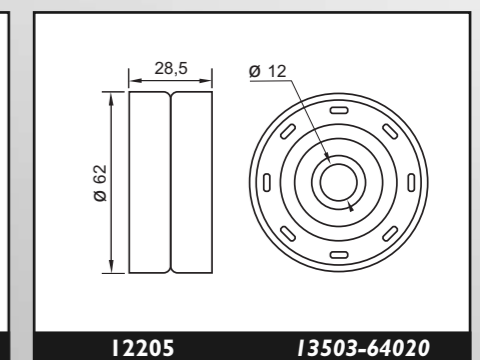
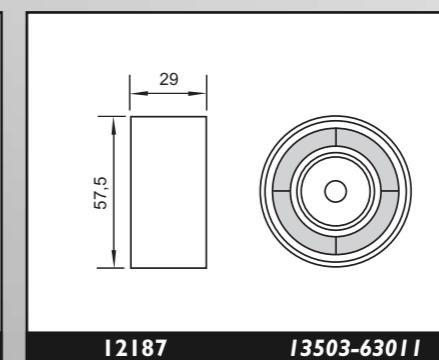
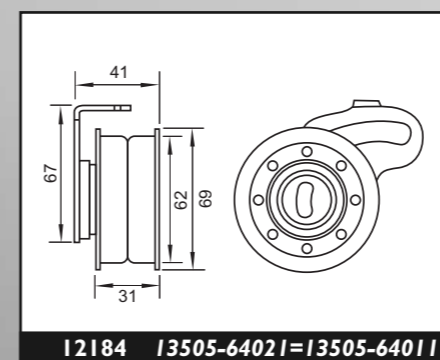
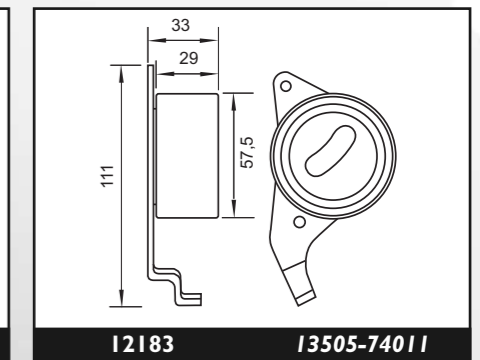
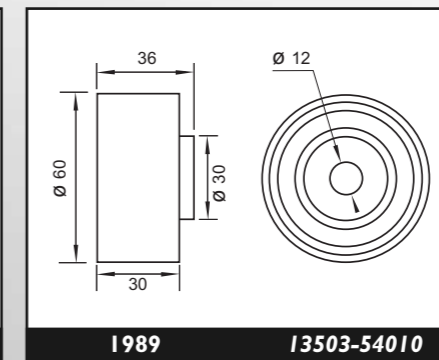
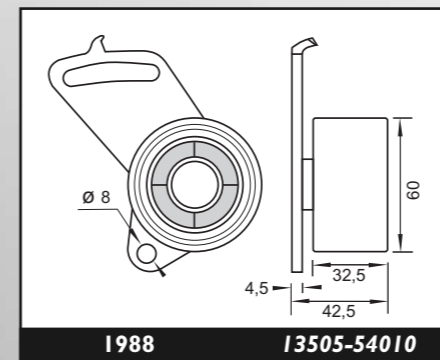
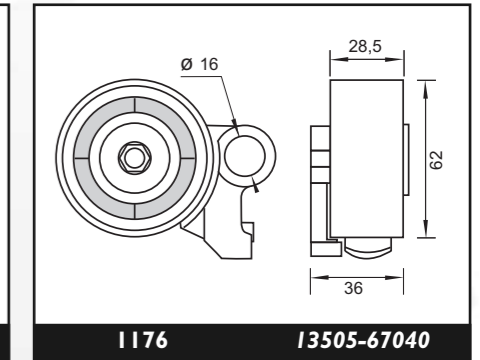
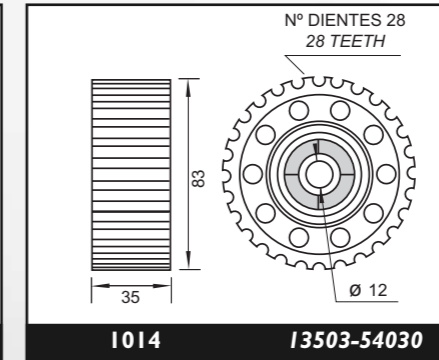
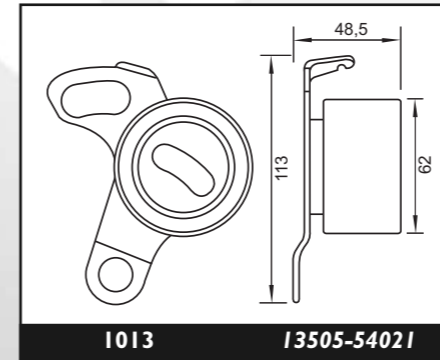

MODELO MODEL	COMB. / FUEL	MOTOR ENGINE	AÑO YEAR		CÓDIGO CODE			NOTA NOTE
			DESDE SINCE	HASTA TO	FIJO FIXED	MÓVIL MOBILE	CÓDIGO ORIGINAL ORIGINAL CODE	

Todo terreno

TOYOTA 4 RUNNER

2.4 D	2429	D	2L	08/83	01/88	1989	1988	
2.4TD	2446	D	2L-T	08/83	01/88	1989	1988	
2.4TD	2446	D	2L-T/TE	02/88	09/93	1014	1013	
3.0TD	2982	D	1KZ-T	10/93	03/96		1176	

TOYOTA KIJANG

2.2 D	2173	D	L	01/81	09/85	1989	1988	
-------	------	---	---	-------	-------	------	------	--

TOYOTA LAND CRUISER

2.4 D	2429	D	2L	11/84	10/85	1989	1988	
2.4TD	2446	D	2L-T	10/85	09/86	1014	1013	
3.0TD	2982	D	1KZ-T	05/93	05/96		1176	
3.0TD	2982	D	1KZ-TE	06/96			1176	
3.0 D-4D	2982	D		11/00			1176	

TOYOTA RAV 4

2.0	1998	N	3S-FE	06/94	06/00	12187	12183	
-----	------	---	-------	-------	-------	-------	-------	--

CÓDIGO CODE	EM	CÓDIGO ORIGINAL ORIGINAL CODE	CÓDIGO CODE	EM	CÓDIGO ORIGINAL ORIGINAL CODE	CÓDIGO CODE	EM	CÓDIGO ORIGINAL ORIGINAL CODE
	1013	13505-54021		1014	13503-54030		1176	13505-67040
	1988	13505-54010		1989	13503-54010		12183	13505-74011
	12187	13503-63011						

EM euromotor[®]

VERSION PDF 2010

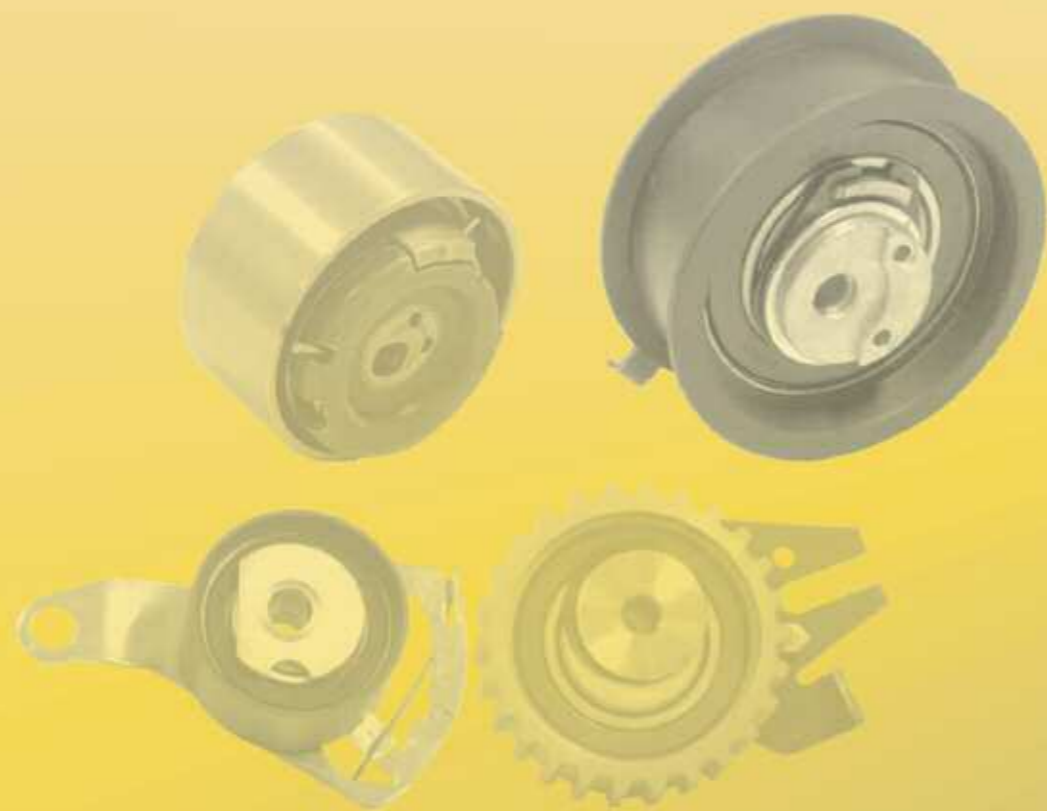

$\varnothing 18$

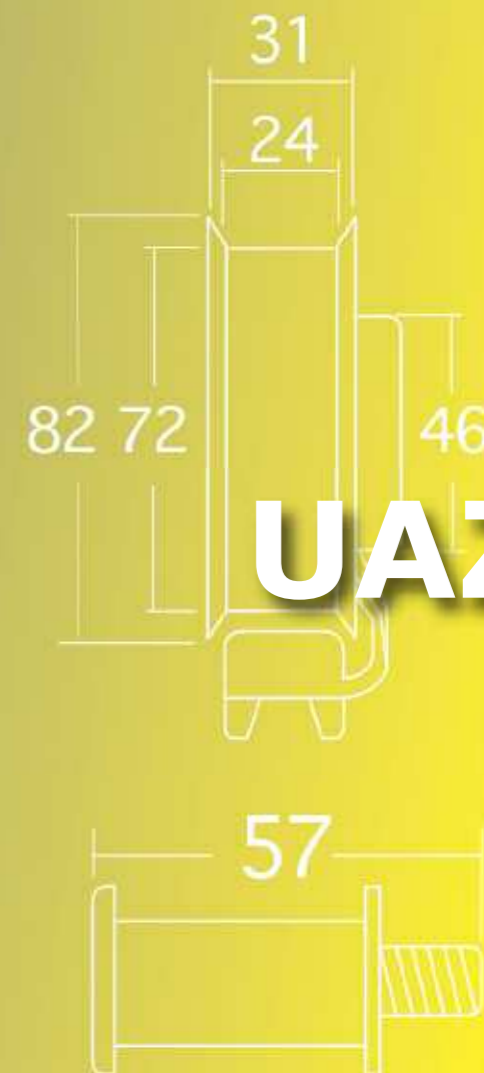

UAZ



MODELO MODEL	COMB. / FUEL	MOTOR ENGINE	AÑO YEAR	CÓDIGO CODE EM euromotor®			
			DESDE SINCE	HASTA TO	FIJO FIXED	MÓVIL MOBILE	NOTA NOTE

UAZ 469

2.1 D	2088	D	XUD11A			1862	1871	
-------	------	---	--------	--	--	------	------	--

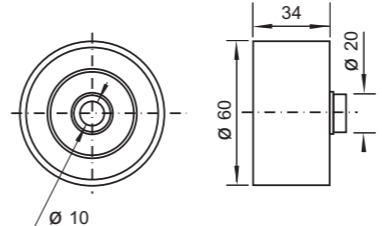
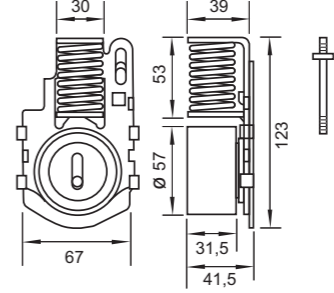
CÓDIGO CODE EM	CÓDIGO ORIGINAL ORIGINAL CODE	CÓDIGO CODE EM	CÓDIGO ORIGINAL ORIGINAL CODE	CÓDIGO CODE EM	CÓDIGO ORIGINAL ORIGINAL CODE
					
1862	9609908980	1871	9605618380		

EM euromotor®

VERSION PDF 2010



$\varnothing 18$

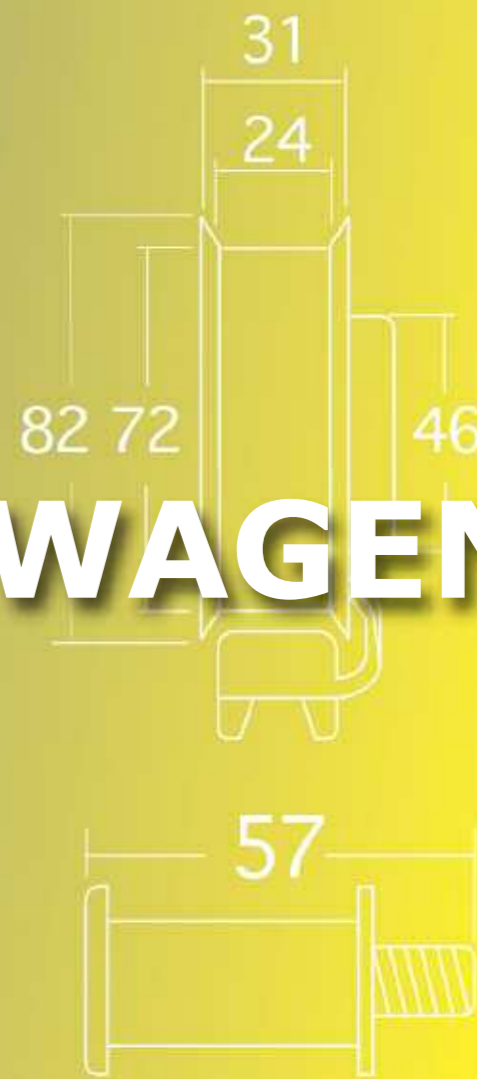

VOLKSWAGEN



MODELO MODEL	COMB. / FUEL	MOTOR ENGINE	AÑO YEAR		CÓDIGO CODE EM euromotor®		
			DESDE SINCE	HASTA TO	FIJO FIXED	MÓVIL MOBILE	NOTA NOTE

VOLKSWAGEN BORA

1.4	1390	N	AHW	09/98		12438 12440	12549 12550	
1.4 16v	1390	N	AKQ	09/98		12438 12440	12549 12550	
1.6	1595	N	AEH - AKL - APF	09/98			1157	
1.6 16v	1595	N	ATN - AUS - BAD AZD - BCB	02/00		12438 12440	12549 12550	
1.4 16v	1390	N	APE - AXP - BCA	05/99		12438 12440	12549 12550	
1.8	1781	N	AGN	09/98		1131 12478	12240 12242	
1.8T	1781	N	AUM - AGU ARX - AUQ	01/00		1131 12478	12240 12242	
2.0	1984	N	APK - AQY - AZG AZN - AZJ	01/99			1157	
1.9 SDi	1896	D	AGP - AHF - AQM - ASV - AGR - ALH	09/98		1166 1131 1167	1107	
1.9TDi	1896	D	AGP - AHF - AQM - ASV - AGR - ALH	09/98		1166 1131 1167	1107	
1.9TDi	1896	D	AJM	09/98		12238	12484 FD99005	Hasta motor Up to engine 185670
1.9TDi	1896	D	AJM	09/98		12238	12239 FD99004	Desde motor From engine 185671
1.9TDi	1896	D	AUY - ATD - ARL - ANU - ASZ	09/98		12238	12239 FD99004	

VOLKSWAGEN CARAT

1.8	1781	N	IP-DX-EV-GU GX-PB-PF-RD-RH	1987	1990		1805	
2.0	1984	N	2E-ADY-AGG-AKR	1990	1993		1805	

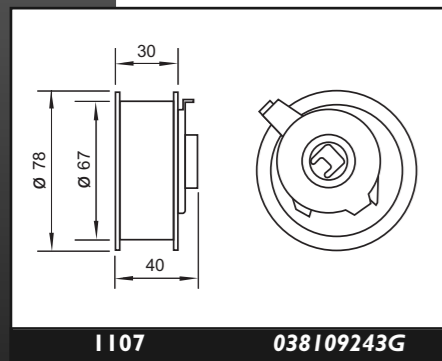

1107 038109243G

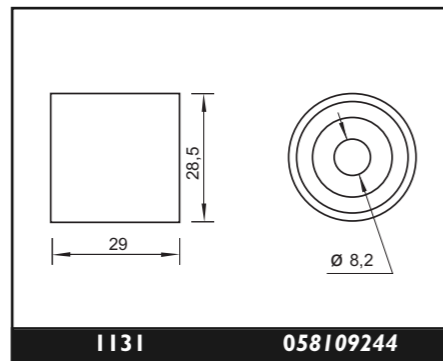

1131 058109244

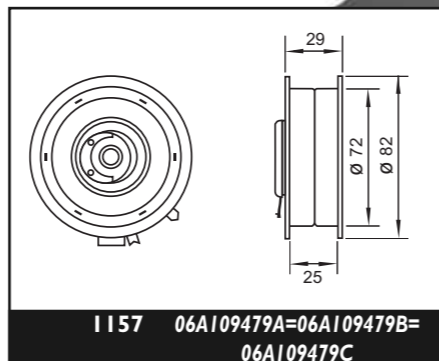

1157 06A109479A=06A109479B=
06A109479C

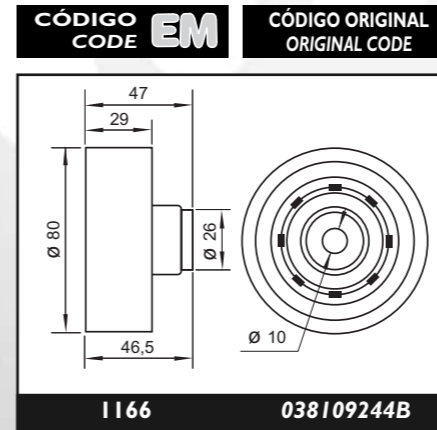

1166 038109244B

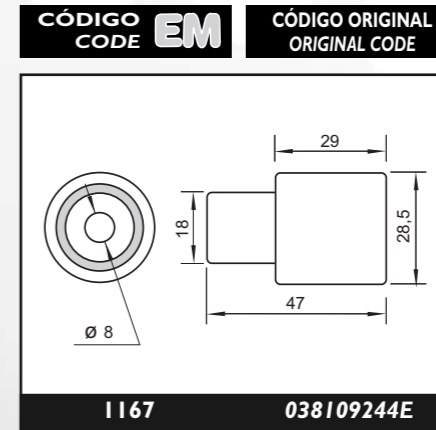

1167 038109244E

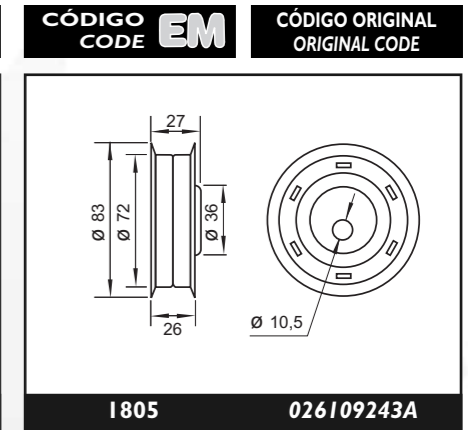

1805 026109243A

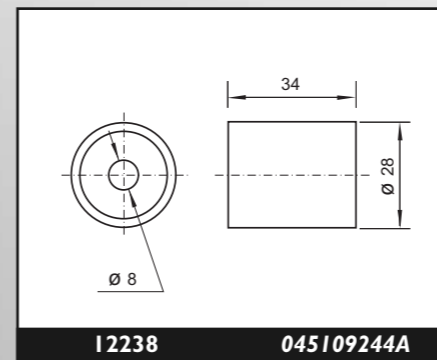

12238 045109244A

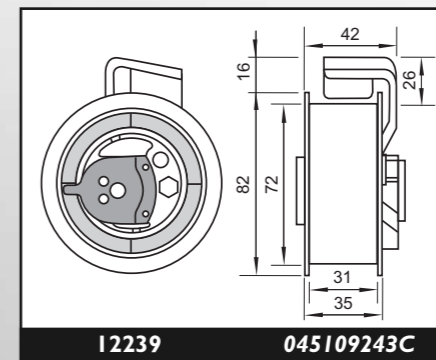

12239 045109243C

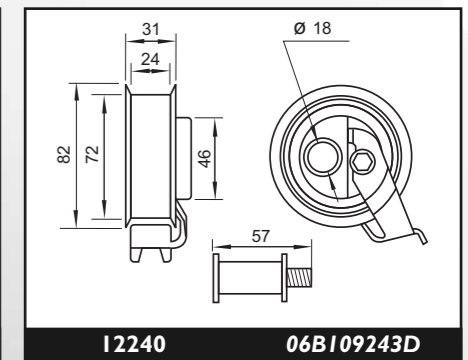

12240 06B109243D

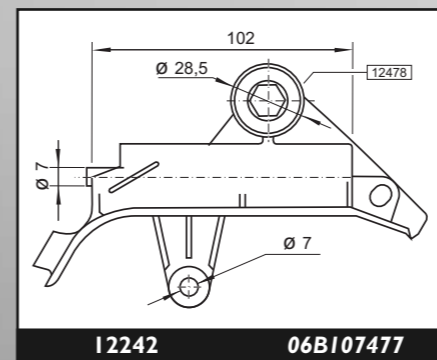

12242 06B107477

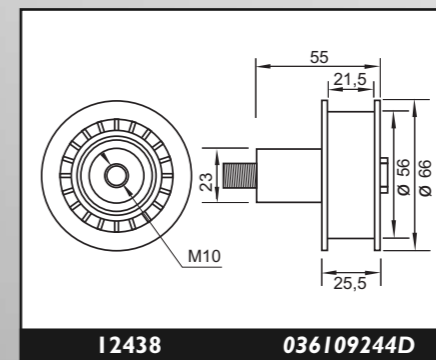

12438 036109244D

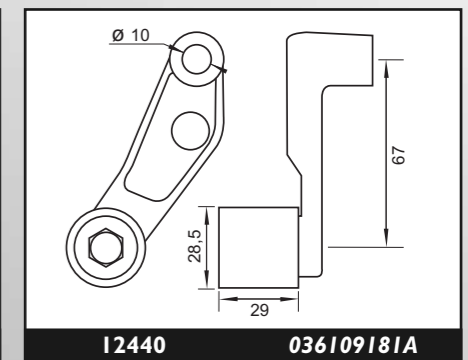

12440 036109181A

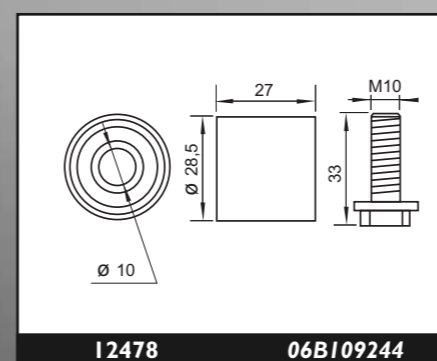

12478 06B109244

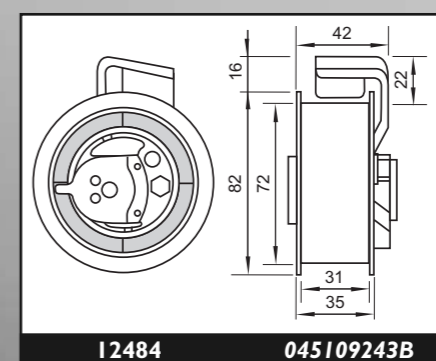

12484 045109243B

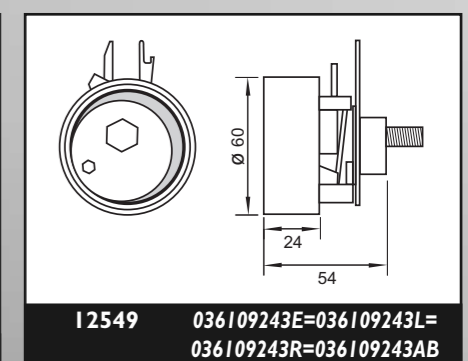

12549 036109243E=036109243L=
036109243R=036109243AB

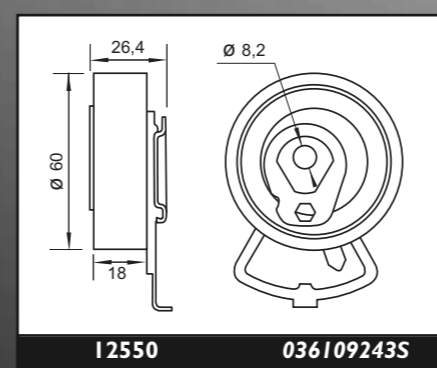

12550 036109243S

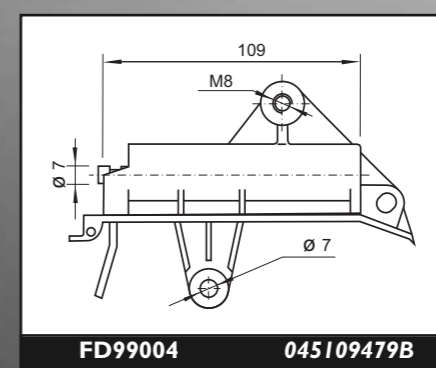

FD99004 045109479B

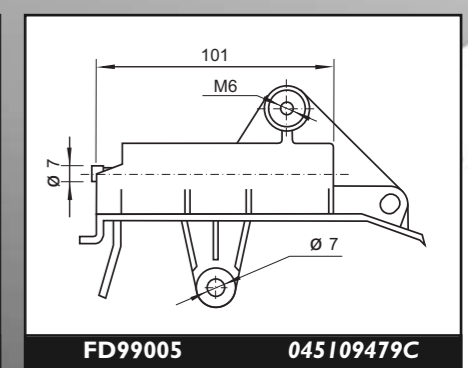

FD99005 045109479C

MODELO MODEL	COMB./ FUEL	MOTOR ENGINE	AÑO YEAR		CÓDIGO CODE		
			DESDE SINCE	HASTA TO	FIJO FIXED	MÓVIL MOBILE	NOTA NOTE

VOLKSWAGEN CORRADO

1.8	1781	N	PG	01/88	09/93		1805
1.8 16v	1781	N	KR	01/89	07/91		1808
2.0	1984	N	ADY	01/88	09/93		1805
2.0	1984	N	ADY-2E	04/93	09/95		1805
2.0 16v	1984	N	9A	01/89	07/91		1808

VOLKSWAGEN FOX

1.6	1595	N	AEE - ALM				12283
1.9 SDi	1896	D	AQM			1131 1166 1167	1107

VOLKSWAGEN GACEL

1.4	1396	N	FY	1986	1990		1805
1.6	1588	N	ABU	1988	1993		1805
1.8	1781	N	IP-DX-EV-GX-RD-RH	1990	1993		1805
1.6 D	1588	D	CR - JK	1991	1993		1806

VOLKSWAGEN GOL I

1.6	1598	N	ABU	1990	1995		1805
1.8	1781	N	ABS	1991	1995		1805
2.0	1984	N	2E - ADY	1991	1995		1805
2.0 GTi	1984	N	ABF	1994	1995		1808

VOLKSWAGEN GOL II

1.6	1598	N	AEA	1996	1998		1805
1.8	1781	N	AAM - ADZ	1996	1998		1805
2.0 8v	1984	N	2E - ADY	1996	1998		1805
2.0 16v	1984	N	ABF	1996	1998		1129
1.6 D	1588	D	JP - ME	1996	1998		1806

CÓDIGO CODE	EM	CÓDIGO ORIGINAL ORIGINAL CODE	CÓDIGO CODE	EM	CÓDIGO ORIGINAL ORIGINAL CODE	CÓDIGO CODE	EM	CÓDIGO ORIGINAL ORIGINAL CODE
1104		028109243F	1107		038109243G	1129		051109243A
1131		058109244	1166		038109244B	1167		038109244E
1805		026109243A	1806		068109243C	1808		027109243
12283		030109243J						

MODELO MODEL	COMB./ FUEL	MOTOR ENGINE	AÑO YEAR		CÓDIGO CODE		
			DESDE SINCE	HASTA TO	FIJO FIXED	MÓVIL MOBILE	NOTA NOTE

VOLKSWAGEN GOL III

1.0	999	N	AER-ALL-ALD-AVC	1999			12283	
1.6	1595	N	AEK - AFT	1991	2005		1805	
1.8	1781	N	AD2 - ANN	1999	2005		1805	
1.9 D	1896	D	IY	1999	2001		1806	
1.9 D	1896	D	IY - AEY	2002	2005		1104	

VOLKSWAGEN GOL IV

1.6	1595	N	AKS	2006	2008		1805	
1.9 SDi	1896	D	AGP	2006	2008	1167 1131 1166	1107	

VOLKSWAGEN GOL V

1.6		N	AEE	2008			12283	
1.9 SDi	1896	D	AGP	2008		1167 1131 1166	1107	

VOLKSWAGEN GOLF

I - 1.5 D	1471	D	CK	08/76	07/80		1806	
I - 1.6D	1595	D	IV-CR-JK-JP-ME	08/76	07/80		1806	
II - 1.5	1498	N	FM - FK - JB - EH	10/74	12/84		1805	
II - 1.5	1498	N	FN - FP - FT - EE	10/74			1805	
II - 1.5	1498	N	EF - EG - FV	10/76			1805	
II - 1.5	1498	N	AFT-AKS	07/95	12/95		1805	
II - 1.6	1595	N	ABW - EZA - EW	06/82			1805	
II - 1.6	1595	N	EW - HM - HN - RE	02/82			1805	
II - 1.6	1595	N	RF - AEK - AKS	02/86	10/91		1805	
II - 1.8 16v	1781	N	KR-PL	12/85	10/91		1808	
II - 2.0 16v	1984	N	ABF	01/91	12/97		1808	Hasta motor Up to engine 20922

CÓDIGO CODE	EM	CÓDIGO ORIGINAL ORIGINAL CODE	CÓDIGO CODE	EM	CÓDIGO ORIGINAL ORIGINAL CODE	CÓDIGO CODE	EM	CÓDIGO ORIGINAL ORIGINAL CODE
1104		028109243F	1107		038109243G	1131		058109244
1166		038109244B	1167		038109244E	1805		026109243A
1806		068109243C	1808		027109243	12283		030109243J

MODELO MODEL	AÑO YEAR	MOTOR ENGINE	CÓDIGO CODE		FIJO FIXED	MÓVIL MOBILE	NOTA NOTE
			DESDE SINCE	HASTA TO			

VOLKSWAGEN GOLF

II - 2.0 16v	1984	N	ABF	01/91	12/97		1129	Desde motor From engine 20923
III - 1.4	1391	N	ABD - AEX	10/91	08/97		12283	
III - 1.6	1598	N	ABU - AEA - AEE	09/92	08/97		12283	
III - 1.6	1595	N	AEA	10/94	07/95	12438	12283	
III - 1.6	1595	N	AEE	10/94	07/95	12438	12283	
III - 1.8	1781	N	DX - EV - EX - HT GU - GX - GZ - HV	01/82	12/94		1805	
III - 1.8	1781	N	SU - KT - PB - PF	11/91	08/97		1805	
III - 1.8	1781	N	RD - RH - RG	11/91	08/97		1805	
III - 1.8	1781	N	ABS - AAM - ADZ	11/91	08/97		1805	
III - 1.8	1761	N	AAM - ADZ - ANN - ANP	11/91	10/00		1805	
III - 2.0 I	1984	N	2E-ADY-AGG-AKR	11/91	08/97		1805	
III - 2.0 GTi	1984	N	ABF	09/92	08/97		1129	
III - 1.9 D	1896	D	IY	11/91	12/98		1806	Hasta motor Up to engine 378364
III - 1.9 D	1896	D	IY	11/91	12/98		1104	Desde motor From engine 378365
III - 1.9TD	1896	D	AAZ	03/91	12/98		1806	Hasta motor Up to engine 378364
III - 1.9TD	1896	D	AAZ	03/91	12/98	1128	1104	Desde motor From engine 378365
III - 1.9TDi	1896	D	IZ	10/93	12/98	1128	1104	Desde motor From engine 289576
III - 1.9 SDi	1896	D	AEY	01/95	12/98	1128	1104	
III - 1.9TDi	1896	D	AHU - ALE	08/96	12/98	1128	1104	(90cv)
III - 1.9TDi	1896	D	AFN	08/96	12/98	1128	1104	(90cv)
IV - 1.4 16v	1390	N	AHW	08/97		12438 12440	12549 12550	Hasta motor Up to engine 160000
IV - 1.4 16v	1390	N	AHW	08/97		12438 12440	12549 12550	Desde motor From engine 160001
IV - 1.4 16v	1390	N	AKQ	08/97		12438 12440	12549 12550	Hasta motor Up to engine 242000

CÓDIGO CODE	EM	CÓDIGO ORIGINAL ORIGINAL CODE	CÓDIGO CODE	EM	CÓDIGO ORIGINAL ORIGINAL CODE	CÓDIGO CODE	EM	CÓDIGO ORIGINAL ORIGINAL CODE
1104		028109243F	1128		028109244	1129		051109243A
1805		026109243A	1806		068109243C	12283		030109243J
12438		036109244D	12440		036109181A	12549		036109243E=036109243L= 036109243R=036109243AB
12550		036109243S						

MODELO MODEL	COMB./FUEL	MOTOR ENGINE	AÑO YEAR		CÓDIGO CODE EM euromotor®		
			DESDE SINCE	HASTA TO	FIJO FIXED	MÓVIL MOBILE	NOTA NOTE

VOLKSWAGEN GOLF

IV - 1.4 16v	1390	N	AKQ	08/97		12438 12440	12549 12550	Desde motor From engine 242001
IV - 1.4 16v	1390	N	APE - AXP - BAD - BCA	08/97		12438 12440	12549 12550	
IV - 1.6	1595	N	AEH - AKL - APF AVU	10/97			1157	
IV - 1.6 16v	1595	N	ATN - AUS AZD - BCD	02/00		12438 12440	12549 12550	
IV - 1.6 FSi	1595	N	BAD	01/02		12438 12440	12549 12550	
IV - 1.8 TURBO	1781	N	AUQ	08/01		12478	12240 12242	
IV - 1.8 20v	1781	N	AGN - APG	10/97		1131	12240 12242	
IV - 1.8 T	1781	N	AGU - AUM ARZ	10/97		1131	12240 12242	
IV - 2.0	1984	N	AKR	04/97	08/98		1805	
IV - 2.0	1984	N	AQY - APK - AZH AZJ - AZG	10/98			1157	
IV - 1.9 SDi	1896	D	ALH - AGP - AQM - AGR	08/97		1166 1131 1167	1107	Hasta motor Up to engine 565000
IV - 1.9 SDi	1896	D	AGR - AHF - ALH AQM	08/97		1166 1131 1167	1107	Desde motor From engine 565001 (90cv)
IV - 1.9 TDi	1896	D	ASV	08/97		1166 1131 1167	1107	(130cv)
IV - 1.9 TDi	1896	D	AJM	08/98		12238	12484 FD99005	Hasta motor Up to engine 185670 (115cv)

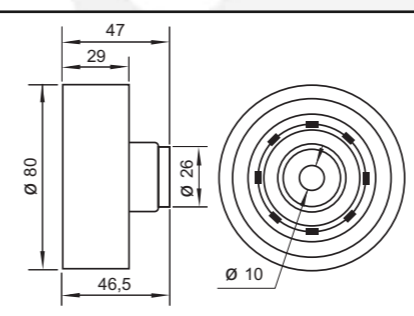
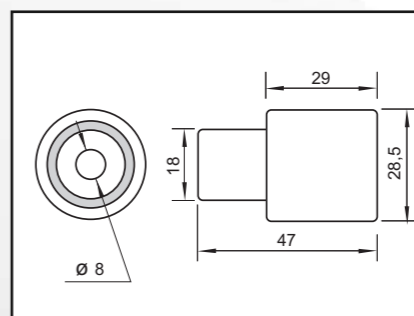
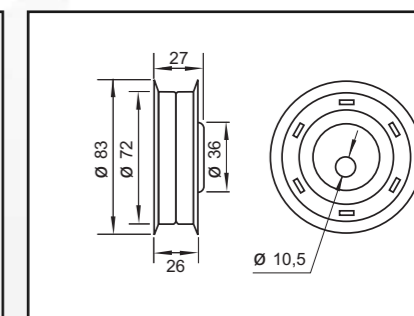
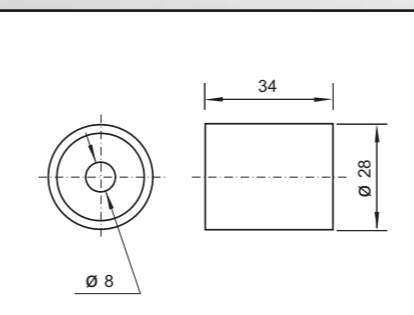
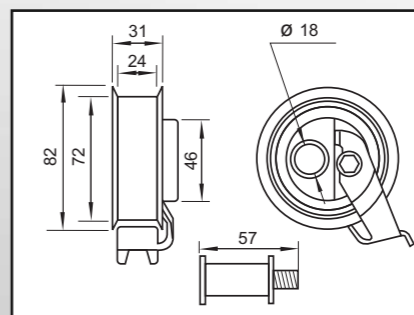
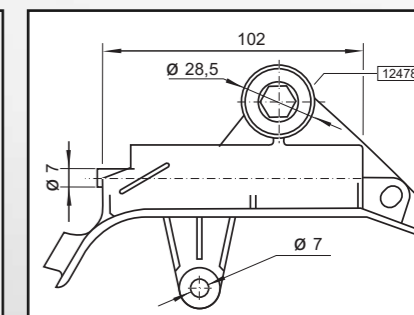
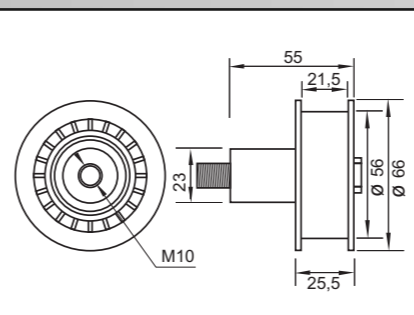
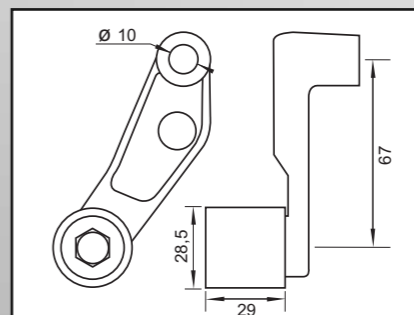
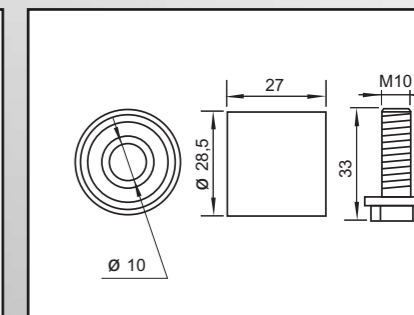
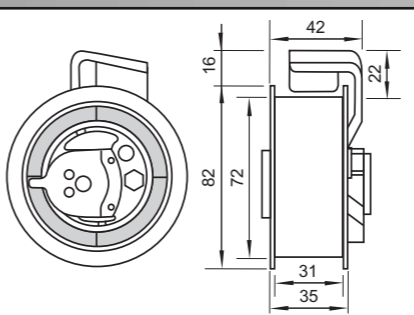
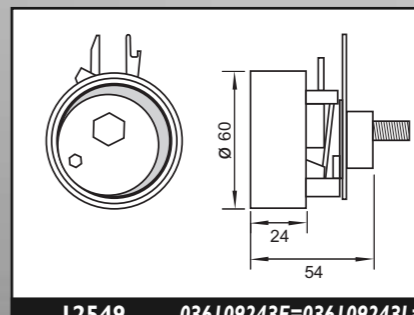
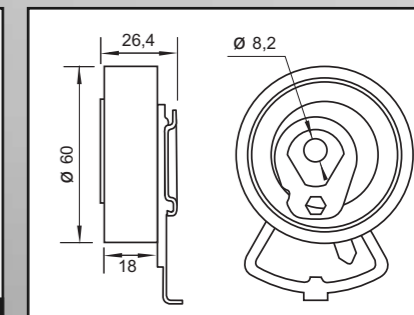
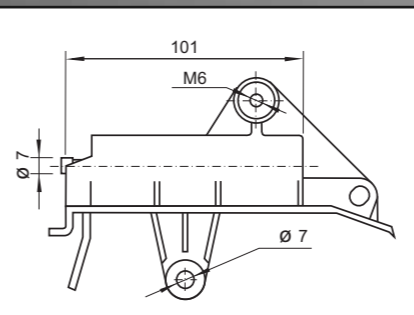
CÓDIGO CODE EM	CÓDIGO ORIGINAL ORIGINAL CODE	CÓDIGO CODE EM	CÓDIGO ORIGINAL ORIGINAL CODE	CÓDIGO CODE EM	CÓDIGO ORIGINAL ORIGINAL CODE
	038109244B		038109244E		026109243A
	045109244A		06B109243D		06B109477
	036109244D		036109181A		06B109244
	045109243B		036109243E=036109243L=036109243R=036109243AB		036109243S
	045109479C				

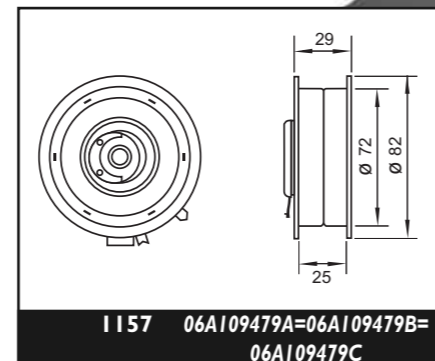
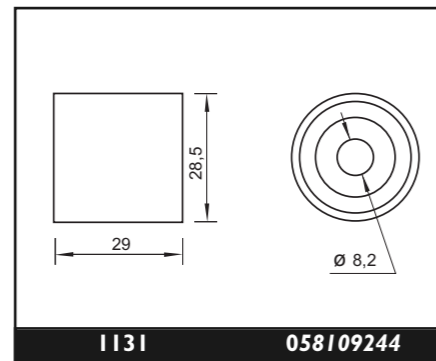
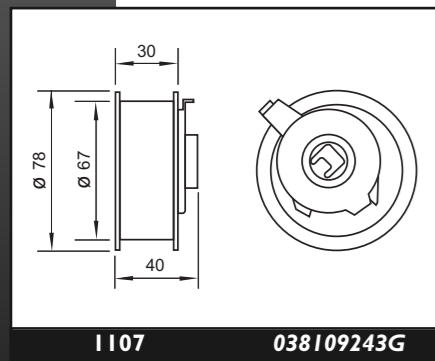

MODELO MODEL	AÑO YEAR	MOTOR ENGINE	CÓDIGO CODE		FIJO FIXED	MÓVIL MOBILE	NOTA NOTE
			EM euromotor®	EM euromotor®			

VOLKSWAGEN GOLF

IV - 1.9 TDi	1896	D	AJM	08/98		12238	12239 FD99004	Desde motor From engine 185671 (115cv)
IV - 1.9 TDi	1896	D	ATD - AUY - ASZ	08/98		12238	12239 FD99004	(130cv)
IV - 1.9 TDi	1896	D	AXR	08/00		12474	12458	(101cv)
IV - 1.9 TDi	1896	D	AGR - AQM - ALH	08/97	01/01	1166 1131 1167	1107	
IV - 1.9 TDi	1896	D	AHF	08/97		1166 1131 1167	1157	
IV - 1.9 TDi	1896	D	ASV - AGR - AQM - ALH	02/01		1166 1131 1167	1157	
IV - 1.9 TDi	1896	D	ARL - BKG	06/01		12474	12458	(150cv)
V - 1.4 16v	1390	N	APE - AXP -	08/03		12438 12440	12549 12550	
V - 1.4 16v	1390	N	BCA	10/03		12438 12440	12549 12550	
V - 1.6	1595	N	BFQ - BSE - BSF	01/04			1157	
V - 2.0 FSi	1984	N	AXW - BVY - BVZ - BLY BLX - BLR - BVX	01/05		12478	12700 12701	
V - 1.9 TDi	1896	D	AKC - BKC - BJB	09/03		12474	12458	
V - 2.0 TDi	1968	D	AZV - BKD	09/03		12474 12475	12458	
V - 2.0 TDi	1968	D	AZV - BKD	01/04		12474 12475	12458	
V - 2.0 TDi	1968	D	BMP (140 HP)	03/04		12474	12458	

CÓDIGO CODE	EM	CÓDIGO ORIGINAL ORIGINAL CODE	CÓDIGO CODE	EM	CÓDIGO ORIGINAL ORIGINAL CODE	CÓDIGO CODE	EM	CÓDIGO ORIGINAL ORIGINAL CODE
1166		038109244B	1167		038109244E	12238		045109244A
12239		045109243C	12438		036109244D	12440		036109181A
12458		038109243M	12474		038109244J	12475		03G109244
12478		06B109244	12549		036109243E=036109243L= 036109243R=036109243AB	12550		036109243S
12700		06D109244A / B	12701		06B109243	FD99004		045109479B

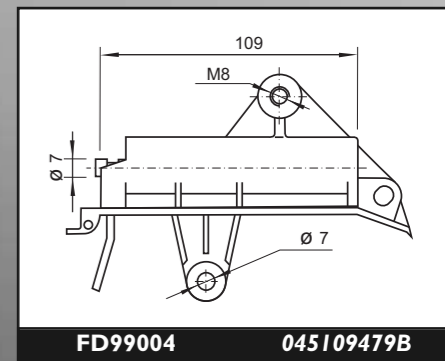
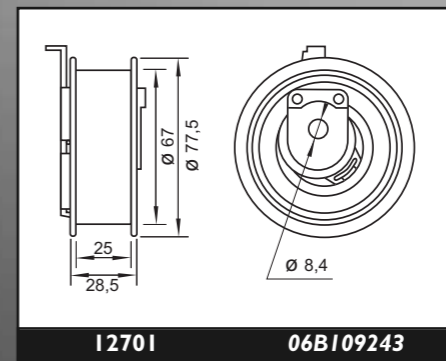
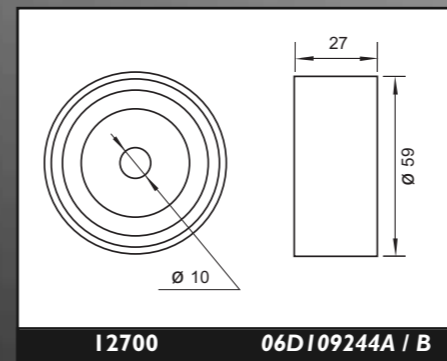
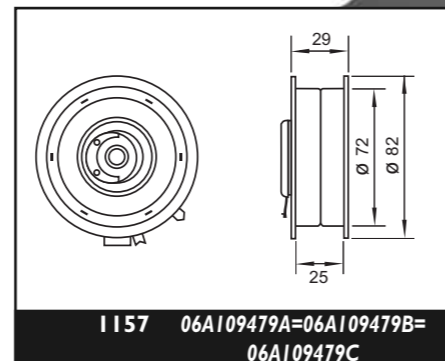
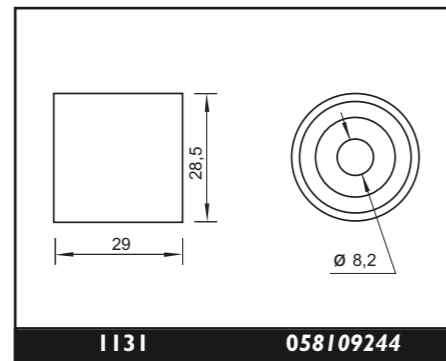
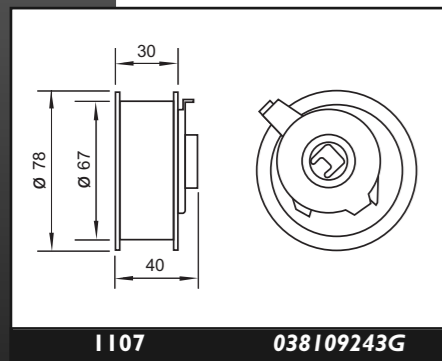

VOLKSWAGEN

VOLKSWAGEN

MODELO MODEL	AÑO YEAR	MOTOR ENGINE	CÓDIGO CODE		FIJO FIXED	MÓVIL MOBILE	NOTA NOTE
			DESDE SINCE	HASTA TO			

VOLKSWAGEN GOLF

V - 2.0TDi	1968	D	BMR (170 HP)	02/05	03/07	12474 12475	12598
V - 2.0TDi	1968	D	BMR (170 HP)	03/07		12474 12597	12598
V - 2.0SDi	1968	D	BDK - BRU - BMM	09/03		12474	12458
VI - 1.6	1595	N	BSE - BSF - CCSA	04/08			1157

VOLKSWAGEN JETTA

1.5	1480	N	FB - FD - GH - JB	01/75	12/84		1805
1.6	1595	N	EZ - PN - RF - EE - EM - FN - FR - FT	01/75	12/84		1805
1.7	1678	N	EZA - EN - PF	01/75	12/84		1805
1.8	1781	N	RV - GU - RP - RH - DX - EV - HV - PB	01/75	12/84		1805
1.8 16v	1791	N	KR - PL - ACC	01/85	12/92		1808
1.6 D	1588	D	CR-JK-JP-ME-CY-JR-MF-RA-SB-IV-SB	01/81	12/92		1806

VOLKSWAGEN LUPO

1.0	999	N	AER - ALL - ALD - ANV - AUC	04/98			12283
1.4	1390	N	AUD	10/99			12283
1.4 16v	1390	N	AHW	04/98		12438 12440	12549 12550
1.4 16v	1390	N	AKQ	04/98		12438 12440	12549 12550
1.4 16v	1390	N	AUA - AUB - AFK - APE-ANM-AQQ-BBY	08/99		12438 12440	12549 12550
1.4 16v	1390	N	ARR	02/01		12438 12440	12549 12550
1.6 16v	1595	N	AVY	09/00		12438 12440	12549 12550

CÓDIGO CODE	EM	CÓDIGO ORIGINAL ORIGINAL CODE	CÓDIGO CODE	EM	CÓDIGO ORIGINAL ORIGINAL CODE	CÓDIGO CODE	EM	CÓDIGO ORIGINAL ORIGINAL CODE
	1157	06A109479A=06A109479B=06A109479C		1805	026109243A		1806	068109243C
	1808	027109243		12283	030109243J		12438	036109244D
	12440	036109181A		12458	038109243m		12474	038109244J
	12475	03G109244		12549	036109243E=036109243L=036109243R=036109243AB		12550	036109243S
	12597	03G109244A		12598	03G109243			

MODELO MODEL	COMB./ FUEL	MOTOR ENGINE	AÑO YEAR		CÓDIGO CODE EM euromotor®		
			DESDE SINCE	HASTA TO	FIJO FIXED	MÓVIL MOBILE	NOTA NOTE

VOLKSWAGEN LUPO

1.2TDi	1191	D	ANY - AYZ	01/99		12238	12239	
1.4TDi	1422	D	AMF	04/98		12238	12484	Hasta motor Up to engine 011494
1.4TDi	1422	D	AMF	04/98		12238	12239	Desde motor From engine 011494

VOLKSWAGEN MULTIVAN

2.0	1984	N	AXA	04/03			1157	
1.9TDI	1896	D	AXB - AXC	04/03		12474	12458	

VOLKSWAGEN NEW BEETLE

1.4 16v	1390	N	BCA	11/01		12438 12440	12549 12550	
1.6	1595	N	AWH - AYD	10/99	02/00		1157	
1.8 20v	1781	N	APH - AVC - AWU AWV-	10/99		12478	12240 12242	
2.0	1984	N	AQY - AEG	08/98			1157	
1.9TDi	1896	D	ALH	01/98		1166 1131 1167	1107	Hasta motor Up to engine 500000
1.9TDi	1896	D	ALH	01/98		1166 1131 1167	1107	Desde motor From engine 500001
1.9TDi	1896	D	ATD	02/01		12238	12239 FD99004	

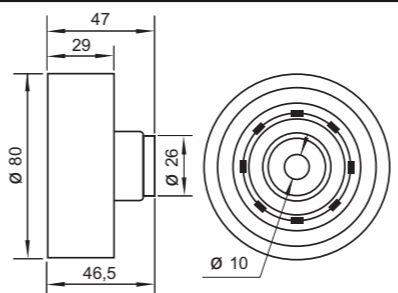
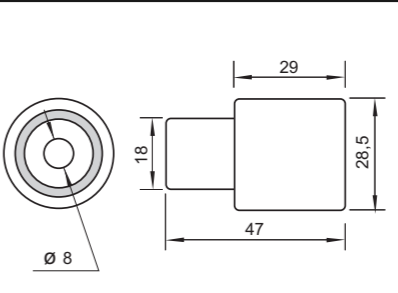
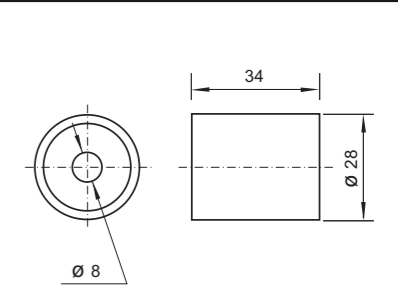
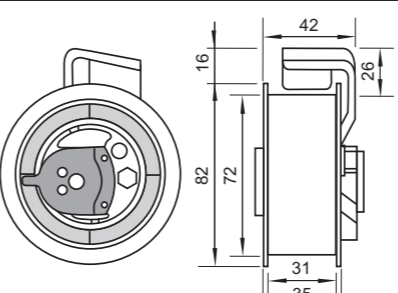
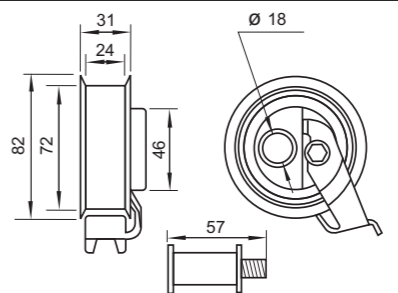
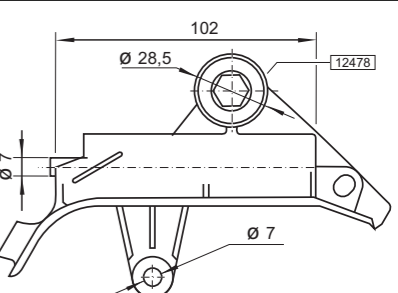
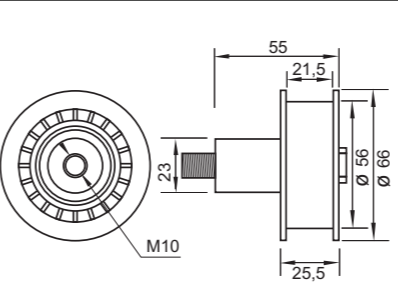
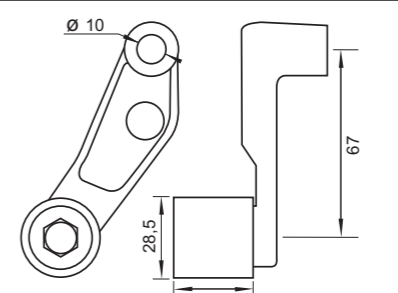
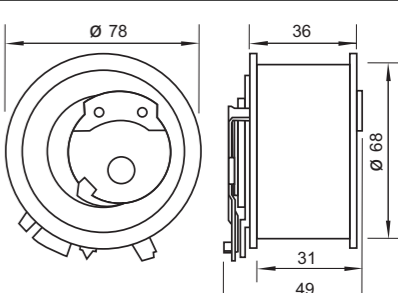
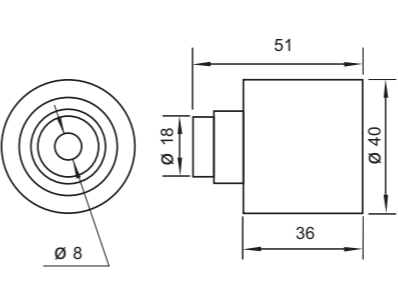
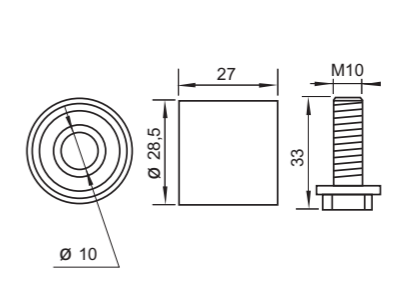
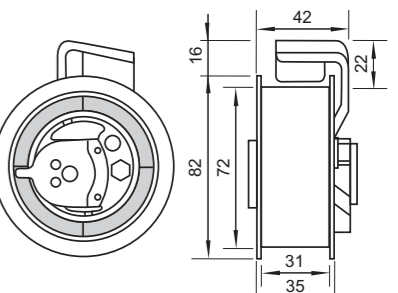
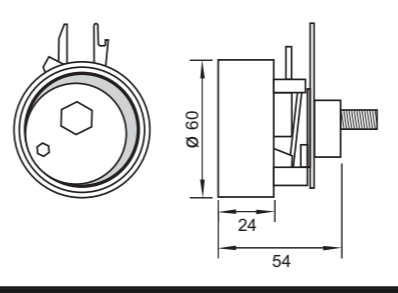
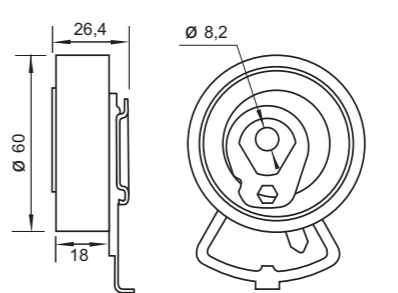
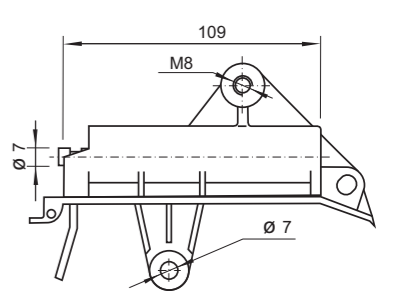
CÓDIGO CODE EM	CÓDIGO ORIGINAL ORIGINAL CODE	CÓDIGO CODE EM	CÓDIGO ORIGINAL ORIGINAL CODE	CÓDIGO CODE EM	CÓDIGO ORIGINAL ORIGINAL CODE
	038109244B		038109244E		045109244A
	045109243C		06B109243D		06B109477
	036109244D		036109181A		038109243m
	038109244J		06B109244		045109243B
	036109243E=036109243L= 036109243R=036109243AB		036109243S		045109479B

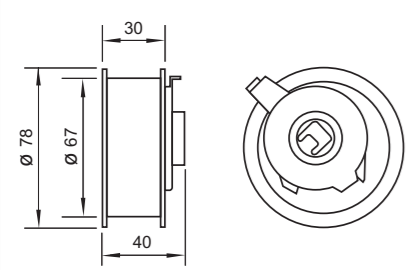

1107 038109243G

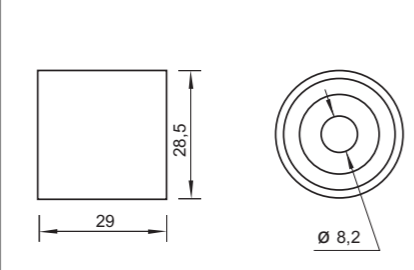

1131 058109244

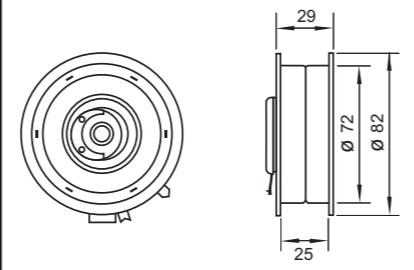

1157 06A109479A=06A109479B=
06A109479C

MODELO MODEL	COMB./FUEL	MOTOR ENGINE	AÑO YEAR		CÓDIGO CODE		
			DESDE SINCE	HASTA TO	FIJO FIXED	MÓVIL MOBILE	NOTA NOTE

VOLKSWAGEN PASSAT

1.6	1598	N	YG - FS - YT - YH	06/75	12/84		1805	
1.6	1598	N	YK - WZ - YS - WY	08/76	12/80		1805	
1.6	1598	N	WP - WV - YN - YP	06/75	12/84		1805	
1.6	1598	N	YY-IF-ABN-RF	06/75	12/84		1805	
1.6	1598	N	AEK	10/94	12/95		1805	
1.6	1598	N	AFT	12/95			1805	
1.6	1598	N	AHL - ALZ ANA - ARM	10/96	11/00		1157	
1.8	1781	N	DS - DZ - JN - JV	01/82			1805	
1.8	1781	N	KR	01/88			1808	
1.8	1781	N	PG	08/88			1805	
1.8	1781	N	AAM - ABS	01/90	09/94		1805	
1.8	1781	N	ADZ	10/94			1805	
1.8 20v	1781	N	AFY	01/97	11/00	1131	12477 12570	Hasta motor Up to engine 010000
1.8 20v	1781	N	AFY	01/97	11/00	1131	12477 12228	Desde motor From engine 010001
1.8 20v	1781	N	ADR - APT - ARG	01/97	11/00	1131	12477 12228	
1.8 20v	1781	N	AEB	10/96	11/00	1131	12477 12228	
1.8 20v	1781	N	ANB - APU	01/98	08/00	1131	12477 12228	
1.8 20v T	1781	N	AWT - AWM	01/00		1131	12240 12242	Hasta Up to chassis 1042384
1.8 20v T	1781	N	AWT - AWM	01/00		1131	12573 12571	Desde From chassis 1042385
2.0	1984	N	2E	01/90	05/97		1805	
2.0	1984	N	ACX	06/93	05/97		1805	
2.0	1984	N	ADY - AEP	10/94	07/95		1808	
2.0	1984	N	AGG	02/90	05/97		1805	
2.0	1984	N	AZM	11/00			1157	

CÓDIGO CODE	EM	CÓDIGO ORIGINAL ORIGINAL CODE	CÓDIGO CODE	EM	CÓDIGO ORIGINAL ORIGINAL CODE	CÓDIGO CODE	EM	CÓDIGO ORIGINAL ORIGINAL CODE
1131		058109244	1157		06A109479A=06A109479B= 06A109479C	1805		026109243A
1808		027109243	12228		058109243C/ E/ F	12240		06B109243D
12242		06B109477	12477		058109479B	12570 / FS00049		059109243J
12571=FD99199		06B109477A	12573		06B109243B			

MODELO MODEL	MOTOR ENGINE	AÑO YEAR		CÓDIGO CODE		
		DESDE SINCE	HASTA TO	FIJO FIXED	MÓVIL MOBILE	NOTA NOTE

VOLKSWAGEN PASSAT

2.0 16v	1984	N	9A	01/88	12/93		1808	
2.0 16v	1984	N	ABF	01/94			1808	Hasta motor Up to engine 20922
2.0 16v	1984	N	ABF	01/94			1129	Desde motor From engine 20923
2.0 20v	1984	N	ALT	11/01		12478	12573 12571	
2.0 FSi	1984	N	BLR - BLY - BVY BBZ	03/05		12478 12595	12573	
2.0 TFSi	1984	N	AXX - BPY - BWA CAWB - CBFA - CCTA	01/07		12478 12595	12573	
2.8 30v	2771	N	ACK - APR - ALG - AQD - AGE - ATX	08/96		12479	12480 12572 FD99014	
1.5 D	1471	D	CK	01/78	12/80		1806	
1.6 D	1588	D	CR- JK	01/81	12/84		1806	
1.6 TD	1588	D	CY - RA - SB	01/81			1806	
1.9 D	1896	D	IY	01/88	10/93		1806	
1.9 TD	1896	D	AAZ	03/91	09/97		1806	
1.9TD	1896	D	AAZ	03/91			1104	Hasta motor Up to engine 552766
1.9TDi	1896	D	IZ	01/93	07/96	1128	1104	Desde motor From engine 289576
1.9 TDi	1896	D	AFN - AHU - AUG	03/96	11/00	1128	1104	
1.9 TDi	1896	D	AHH	03/96	11/00	1128	1104	
1.9 TDi	1896	D	AJM	08/98		12238	12484 FD99005	Desde motor From engine 185670

CÓDIGO CODE	EM	CÓDIGO ORIGINAL ORIGINAL CODE	CÓDIGO CODE	EM	CÓDIGO ORIGINAL ORIGINAL CODE	CÓDIGO CODE	EM	CÓDIGO ORIGINAL ORIGINAL CODE
1806		068109243C	1808		027109243	12238		045109244A
12478		06B109244	12479		078109244H	12480		078109243Q
12484		045109243B	12571=FD99199		06B109477A	12572=FD99001		078109479E
12573		06B109243B	12595		06B109244C/D/E	FD99005		045109479C
FD99014		078109487A						

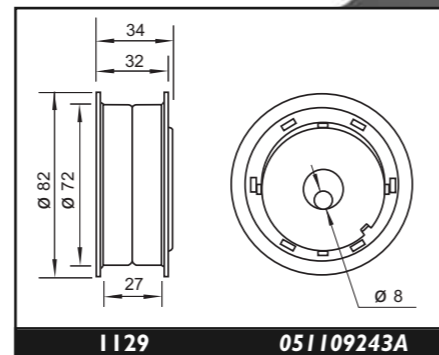
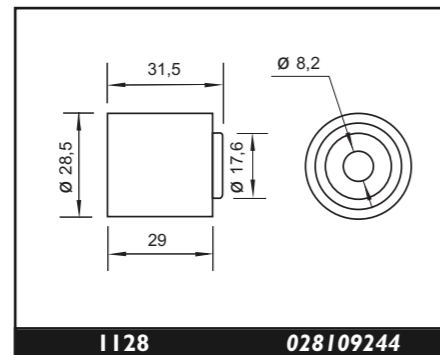
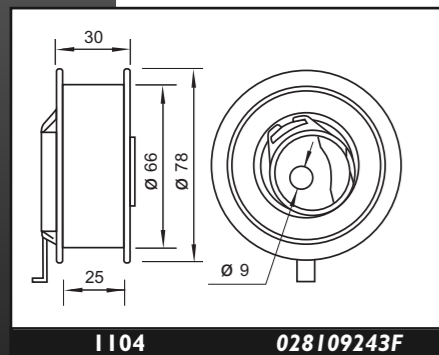

MODELO MODEL	AÑO YEAR	MOTOR ENGINE	CÓDIGO CODE			NOTA NOTE
			DESDE SINCE	HASTA TO	EM euromotor®	

VOLKSWAGEN PASSAT

MODELO MODEL	AÑO YEAR	MOTOR ENGINE	DESDE SINCE	HASTA TO	EM euromotor®	NOTA NOTE	
1.9 TDi	1896	D	AJM	08/98	12238	12239 FD99004	Hasta motor Up to engine 185671
1.9 TDi	1896	D	ATJ - AVB - AVF - AWX	08/99	12238	12239 FD99004	
2.0 TDi	1968	D	BGW	12/03	12474	12458	
2.0 TDi	1968	D	AZV	04/04	12474 12475	12458	
2.0 TDi	1968	D	BMP	02/05	12474	12458	
2.0 TDi	1968	D	BMR	02/05	12474 12475	12598	Hasta Up to chassis 3C-6-300.000
2.0 TDi	1968	D	BMR	02/05	12474	12598 12597	Desde From chassis 3C-6-300.001
2.0 TDi	1968	D	CBAA - CBAB - CBBB	01/08		12599	
2.5 TDi	2496	D	AFB - AKN	08/98	12575	12574 12570 FD99003 FD99002	
2.5 TDi	2496	D	AKE	08/98	12575	12570 12574 FD99003 FD99002	

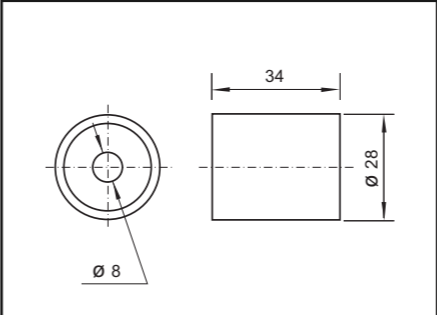
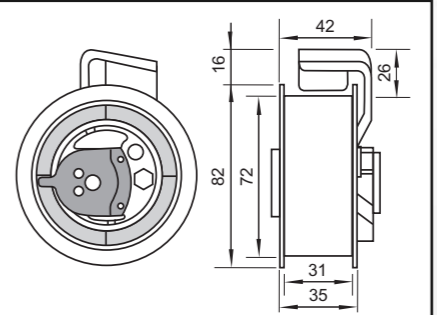
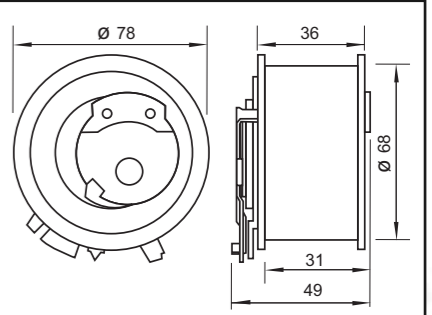
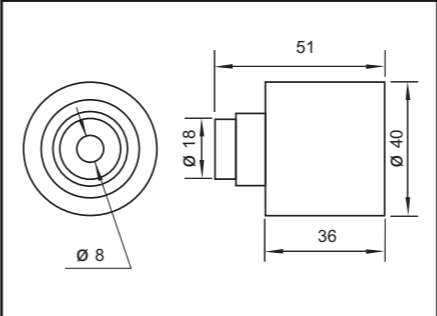
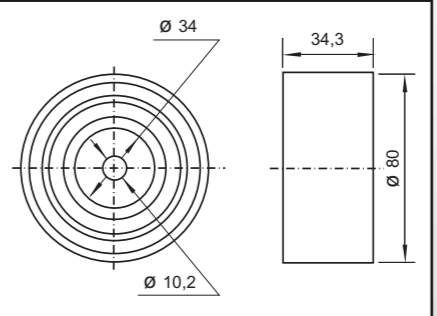
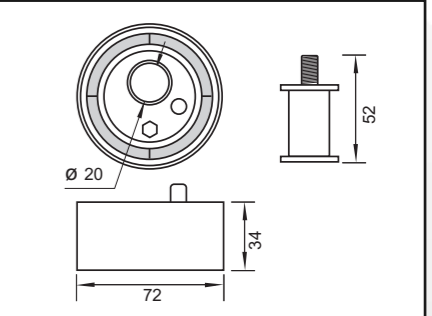
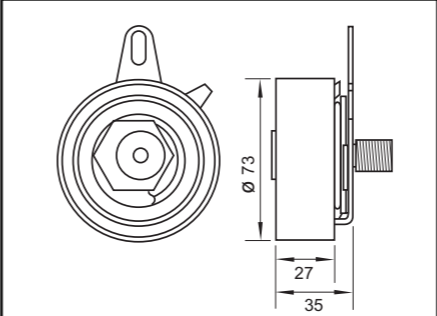
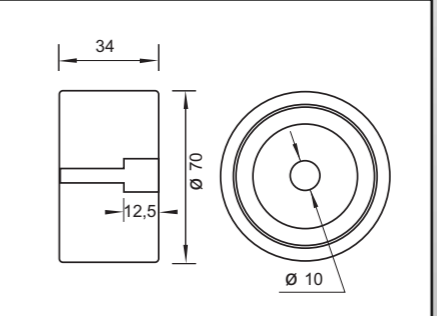
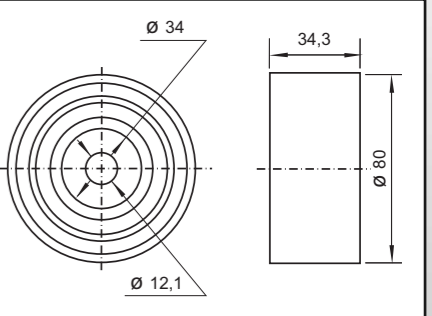
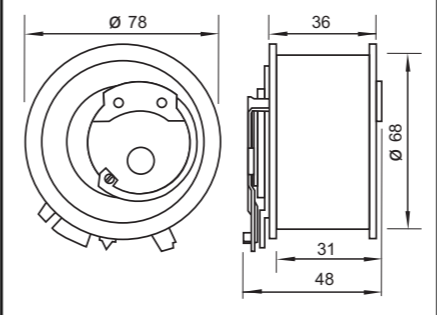
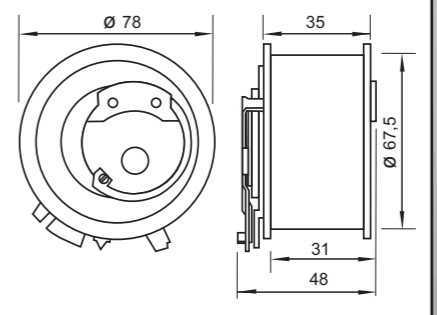
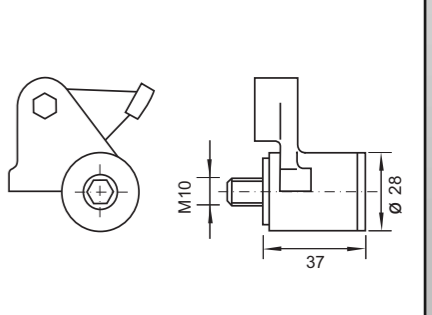
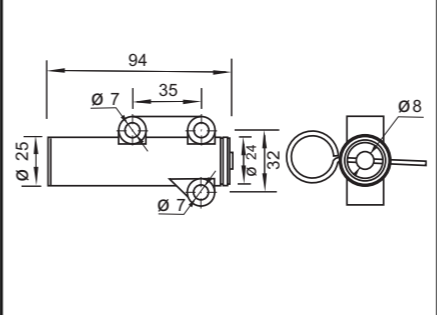
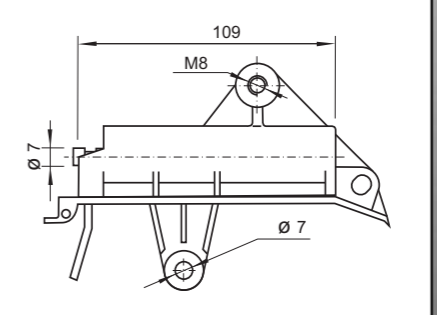
CÓDIGO CODE	EM	CÓDIGO ORIGINAL ORIGINAL CODE	CÓDIGO CODE	EM	CÓDIGO ORIGINAL ORIGINAL CODE	CÓDIGO CODE	EM	CÓDIGO ORIGINAL ORIGINAL CODE
	12238	045109244A		12239	045109243C		12458	038109243M
	12474	038109244J		12475	03G109244		12570 / FS00049	059109243J
	12574	059109243G		12575	059109244A=059109244B		12597	03G109244A
	12598	03G109243		12599	03L109243A/E		FD99002	059109487A
	FD99003	059109479B		FD99004	045109479B			

MODELO MODEL	COMB./FUEL	MOTOR ENGINE	AÑO YEAR		CÓDIGO CODE EM euromotor®		
			DESDE SINCE	HASTA TO	FIJO FIXED	MÓVIL MOBILE	NOTA NOTE

VOLKSWAGEN POLO

I.8		N	ADD - ADZ	11/95			1805	
I.8		N	ADD - ADZ	03/98			1805	
I.4TDi		D	AMF - BAY	01/99		12238	12573	
I.4TDi		D	AMF - BAY	01/99		12238	12239	
I.7SDi		D	AKU - AHG	08/97		1128		
I.7SDi Classic		D	AKW	08/97	09/01	1128	1104	
I.9D Variant		D	IY-IZ	10/95	09/01	1128	1104	
I.9SDi		D	AGD - ASX - AEF	10/94		1128		
I.9SDi		D	AEY	11/95	09/01	1128	1104	
I.9SDi		D	AGP - AQM	06/99		1166 1131 1167	1104	Hasta motor Up to engine 595000
I.9SDi		D	AGP - AQM	06/99		1166 1131 1167	1107	Desde motor From engine 595001
I.9TDi		D	ALH	09/96		1166 1131 1167	1104	Hasta motor Up to engine 500000 - 565000
I.9TDi		D	ALH	09/96		1166 1131 1167	1107	Desde motor From engine 500001 - 565001
I.9TDi		D	AGR	09/96		1166 1131 1167	1104	Hasta motor Up to engine 500000 - 565000
I.9TDi		D	AGR	09/96		1166 1131 1167	1107	Desde motor From engine 500001 - 565001
I.9TDi		D	ASV	06/98		1166 1131 1167	1104	Hasta motor Up to engine 500000 - 565000
I.9TDi		D	ASV	06/98		1166 1131 1167	1107	Desde motor From engine 500001 - 565001
I.9TDi		D	ATD - AXR	11/02		12474	12458	

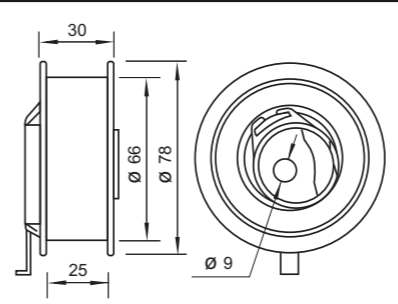
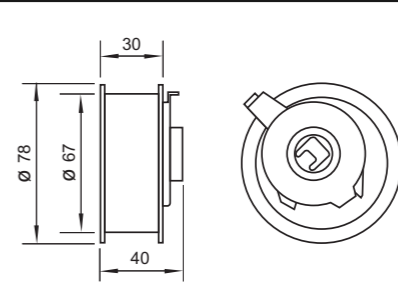
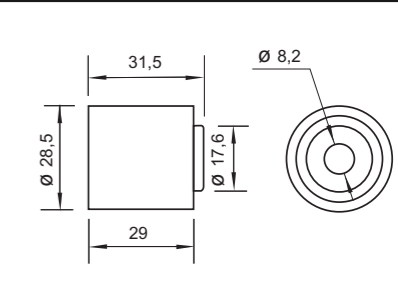
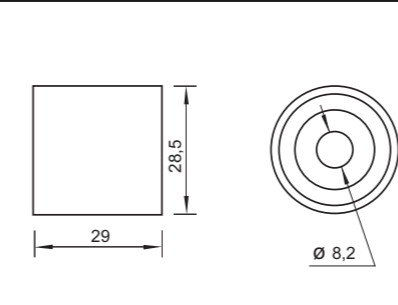
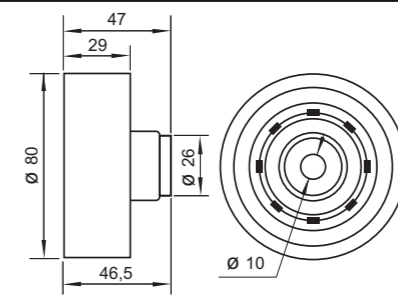
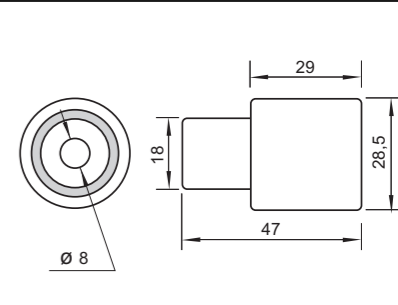
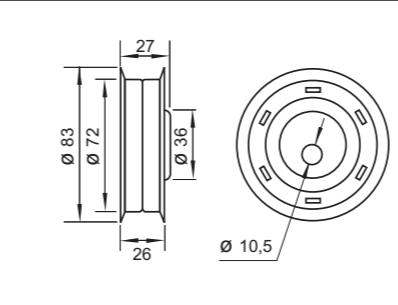
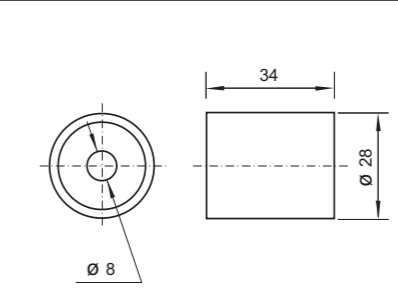
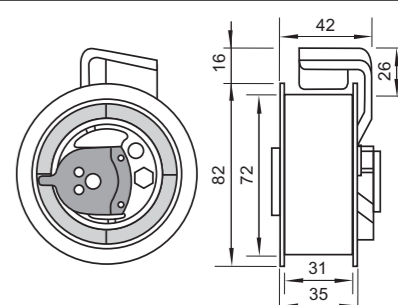
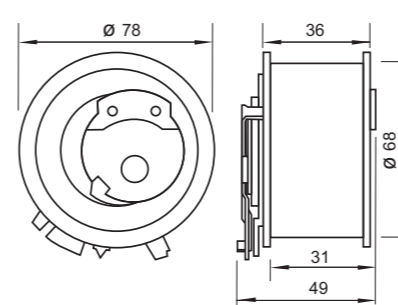
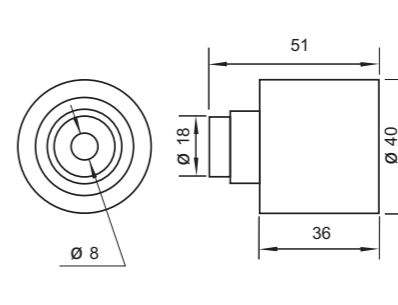
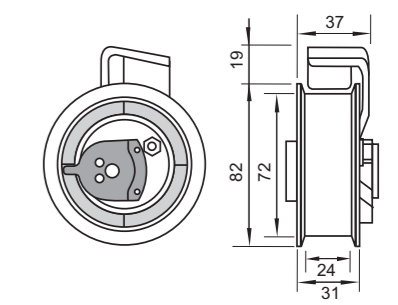
CÓDIGO CODE EM	CÓDIGO ORIGINAL ORIGINAL CODE	CÓDIGO CODE EM	CÓDIGO ORIGINAL ORIGINAL CODE	CÓDIGO CODE EM	CÓDIGO ORIGINAL ORIGINAL CODE
	028109243F		038109243G		028109244
	058109244		038109244B		038109244E
	026109243A		045109244A		045109243C
	038109243m		038109244J		06B109243B

MODELO MODEL	COMB./FUEL	MOTOR ENGINE	AÑO YEAR		CÓDIGO CODE			NOTA NOTE
			DESDE SINCE	HASTA TO	FIJO FIXED	MÓVIL MOBILE	EM euromotor®	

VOLKSWAGEN QUANTUM

1.8	1781	N	ADZ -ANN	1992	2000		1805	
2.0	1984	N	AGG	1992	2000		1805	

VOLKSWAGEN SANTANA

2.0	1984	N	AGG	2003	2007		1808	Man.Tens.
-----	------	---	-----	------	------	--	------	-----------

VOLKSWAGEN SAVERIO I

1.6	1598	N	ABU	1990			1805	
1.6 D	1588	D	JP - ME	1991			1806	

VOLKSWAGEN SAVERIO II

1.6	1598	N	AEA	1998			1805	
1.9 SDi	1896	D	IY	1999			1806 1104	Man.Tens. Aut. Tens.

VOLKSWAGEN SAVERIO III

1.6	1598	N	AEK	2006			1805	
1.9 SDi	1896	D	AGP	2006		1131 1166 1167	1107	

VOLKSWAGEN SCIROCCO

1.5	1480	N	EH - FB - FD - FH-FK	01/75	12/94		1805	
1.6	1598	N	EE - EG - FN - FT- HN	01/85	12/92		1805	
1.7	1698	N	EN	01/80	12/84		1805	
1.8	1781	N	DX - EX - JH - RE	01/82	12/92		1805	
1.8 16v	1781	N	KR-PL	01/86	12/92		1808	

VOLKSWAGEN SENDA

1.6	1585	N	ABU	1991			1805	
1.6 D	1588	D	CR - JK	1993			1806	

CÓDIGO CODE	EM	CÓDIGO ORIGINAL ORIGINAL CODE	CÓDIGO CODE	EM	CÓDIGO ORIGINAL ORIGINAL CODE	CÓDIGO CODE	EM	CÓDIGO ORIGINAL ORIGINAL CODE
1104		028109243F	1107		038109243G	1131		058109244
1166		038109244B	1167		038109244E	1805		026109243A
1806		068109243C	1808		027109243			

MODELO MODEL	COMB. / FUEL	MOTOR ENGINE	AÑO YEAR		CÓDIGO CODE		
			DESDE SINCE	HASTA TO	FIJO FIXED	MÓVIL MOBILE	NOTA NOTE

VOLKSWAGEN SURAN

1.9 SDi	1896	D	ARM	2007		1131 1166 1167	1107
---------	------	---	-----	------	--	----------------------	------

VOLKSWAGEN TIGUAN

2.0 TFSi	1984	N	CAWA - CAWB	09/08		12478 12595	12573
2.0 TDi	1968	D	BMP (140 HP)	09/08		12474	12458
2.0 TDi	1968	D	BMR (170 HP)	09/08		12474	12597 12598

VOLKSWAGEN TOUAREG

4.2 v8	4172	N	AXQ	10/02		12576	12577 FD99022 FS99012
--------	------	---	-----	-------	--	-------	-----------------------------

VOLKSWAGEN TOURAN

1.6	1595	N	BGV	07/03			1157
1.6 FSI	1598	N	BAD	07/03		12438 12440	12549 12550

CÓDIGO CODE	EM	CÓDIGO ORIGINAL ORIGINAL CODE	CÓDIGO CODE	EM	CÓDIGO ORIGINAL ORIGINAL CODE	CÓDIGO CODE	EM	CÓDIGO ORIGINAL ORIGINAL CODE
----------------	----	----------------------------------	----------------	----	----------------------------------	----------------	----	----------------------------------

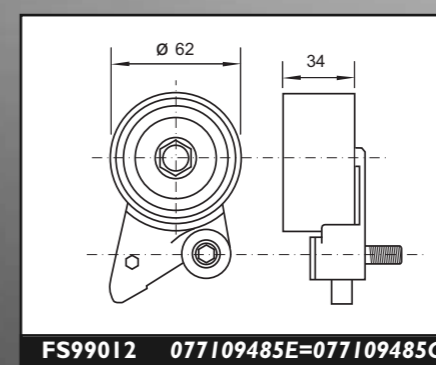
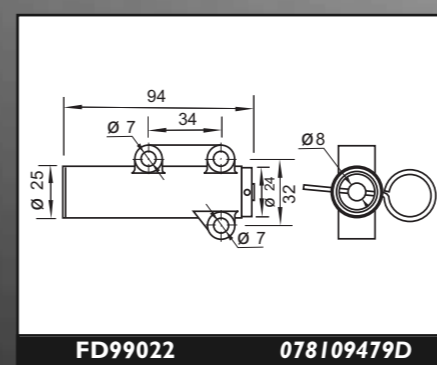
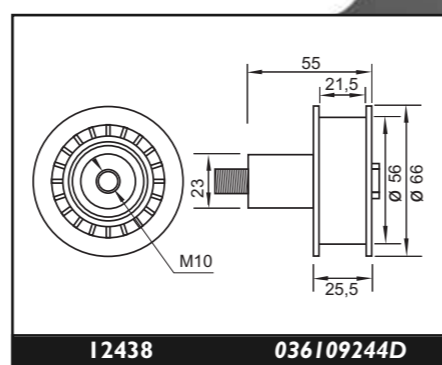
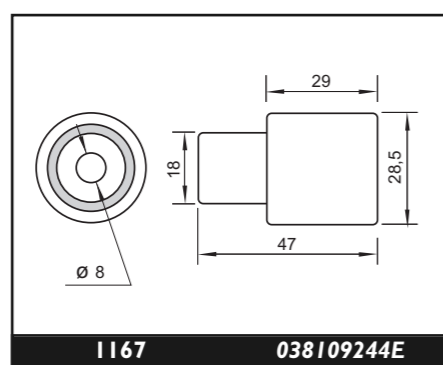
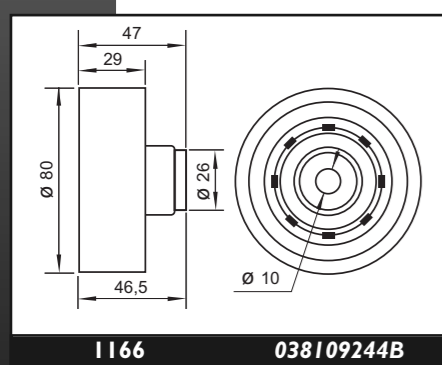
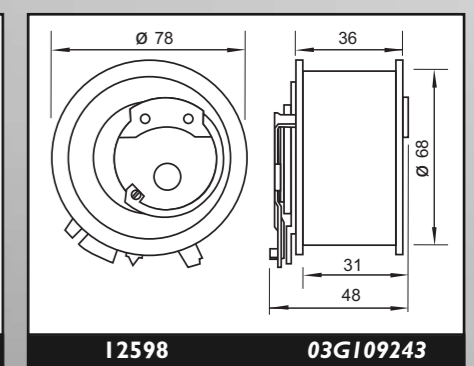
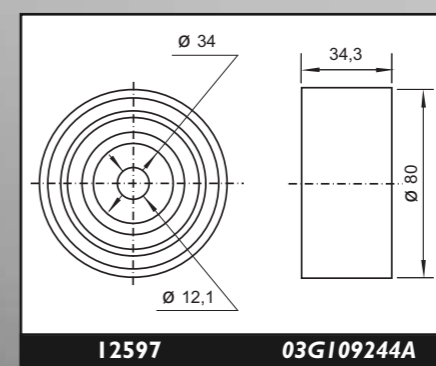
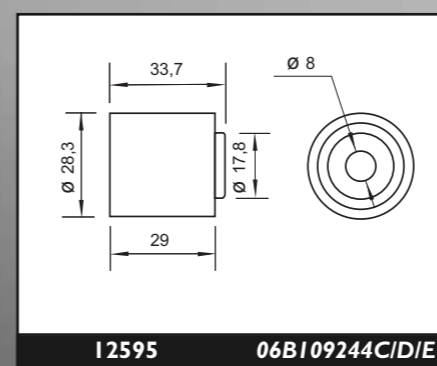
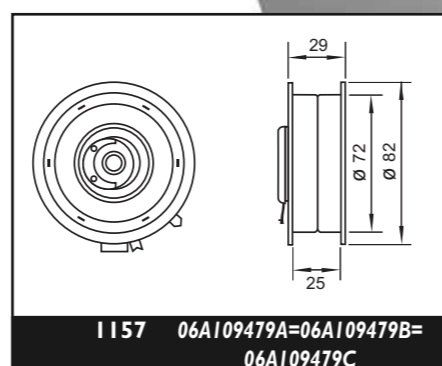
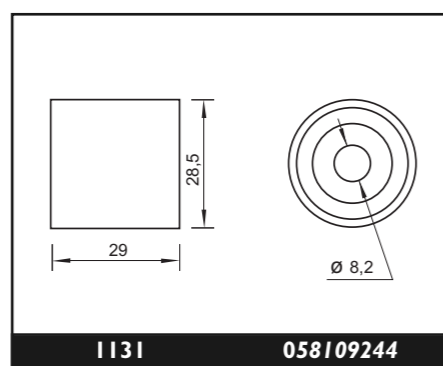
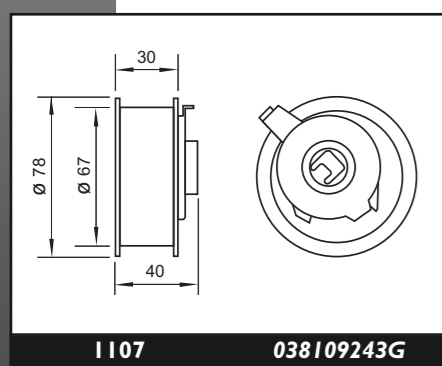
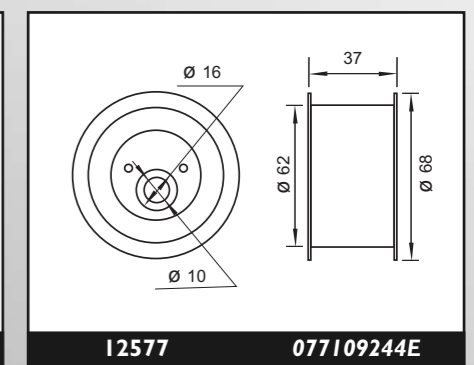
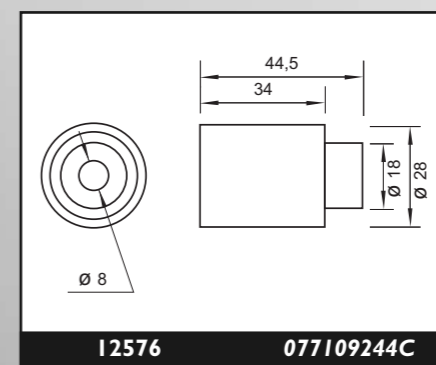
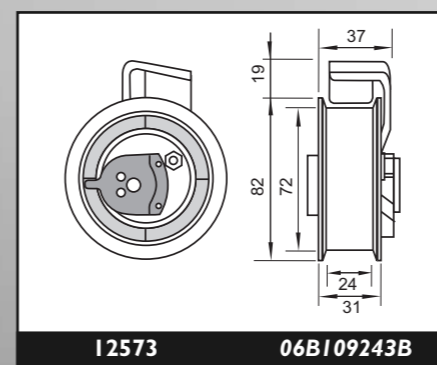
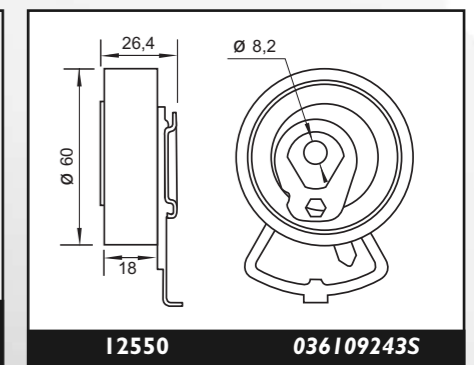
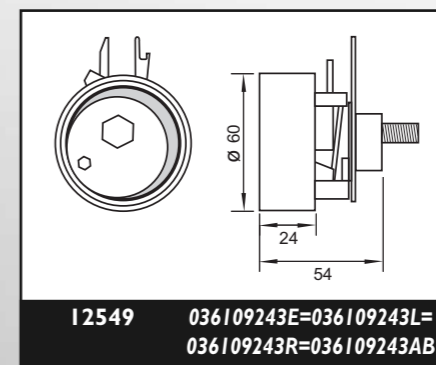
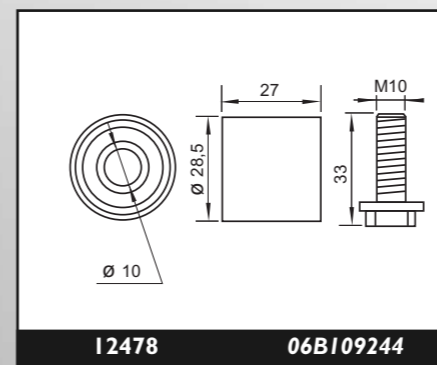
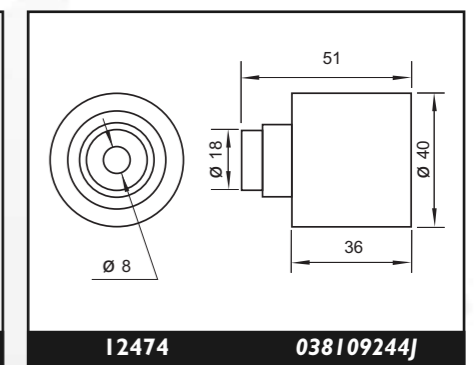
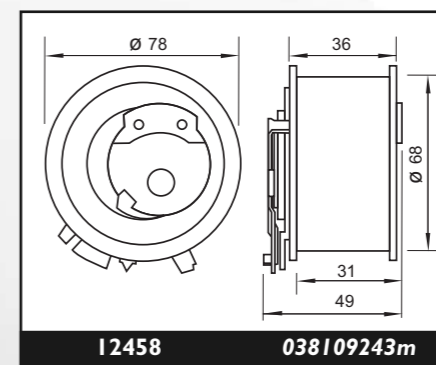
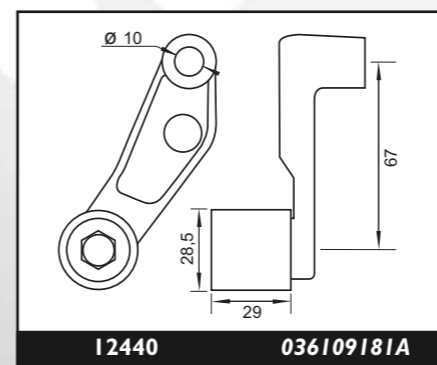

VOLKSWAGEN

VOLKSWAGEN

MODELO MODEL	AÑO YEAR	MOTOR ENGINE	CÓDIGO CODE		FIJO FIXED	MÓVIL MOBILE	NOTA NOTE
			DESDE SINCE	HASTA TO			

VOLKSWAGEN TOURAN

1.9TDI	1896	D	AVQ	02/03		12474	12458	
1.9TDI	1896	D	BKC	02/03		12474	12458	
2.0TDI	1968	D	AZV-BKD	02/03		12474 12475	12458	

VOLKSWAGEN VENTO

1.4	1390	N	AEX	05/95			12283	
1.4	1390	N	APQ	11/97	05/99		12283	
1.6	1595	N	AEK	01/94	12/95		1805	
1.6	1595	N	AFT	05/96			1805	
1.6	1595	N	AEE	05/96			12283	
1.8	1781	N	AAM - ABS - ADZ	01/92	08/98		1805	
2.0	1984	N	2E - AKR - ADY - AEP - AGG	01/94	12/98		1805	
2.0 FSi	1984	N	BLR - BLY - BLY - BBZ	02/07		12478 12595	12573	
2.0 TFSi	1984	N	AXX - BPY - BWA CAWB - CBFA - CCTA	02/07		12478 12595	12573	
1.9 D	1896	D	IY	01/92			1806	Hasta motor Up to engine 378364
1.9 D	1896	D	IY	01/92			1104	Desde motor From engine 378365
1.9 TD	1896	D	AAZ	01/92			1806	Hasta motor Up to engine 378364
1.9 TD	1896	D	AAZ	01/92			1104	Desde motor From engine 378365
1.9 SDi	1896	D	AEY	05/96		1128	1104	Desde motor From engine 289576
1.9 TDi	1896	D	AFN - ALE - AHU	05/96		1128	1104	Desde motor From engine 289576
1.9 TDi	1896	D	BKC - BLS - BXE	09/07		12474	12458	
2.0 TDi	1968	D	BMP (140HP)	02/07		12474	12458	
2.0 TDi	1968	D	BMR (170HP)	02/07		12474	12598 12597	

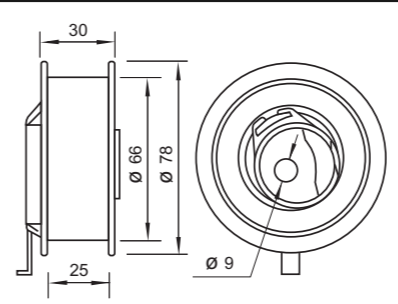
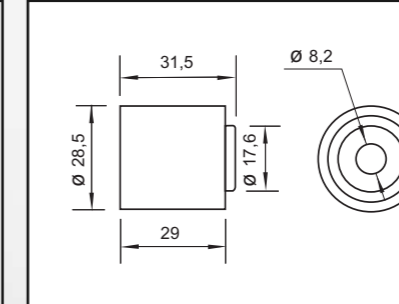
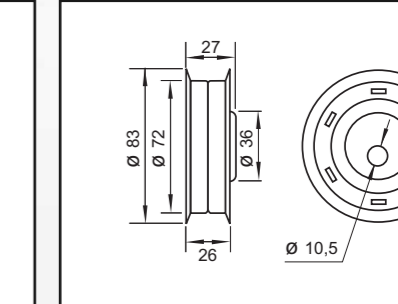
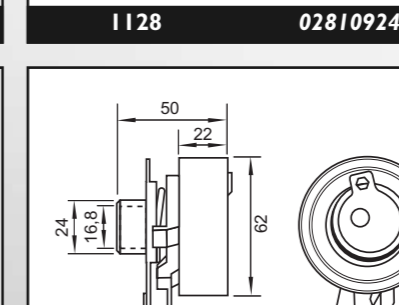
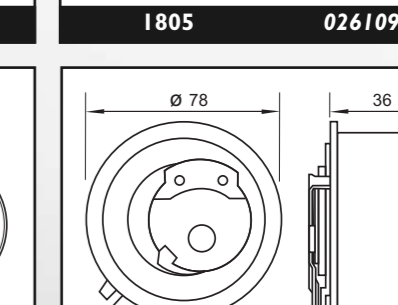
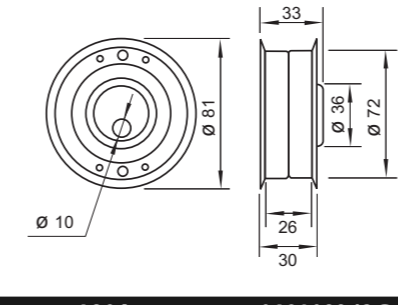
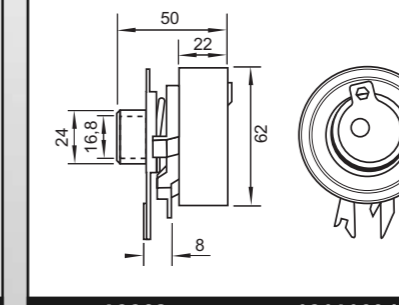
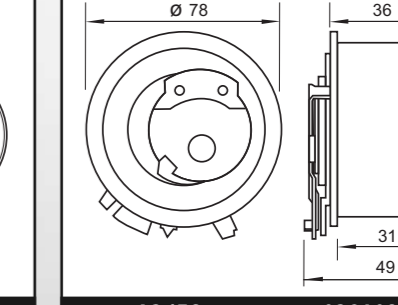
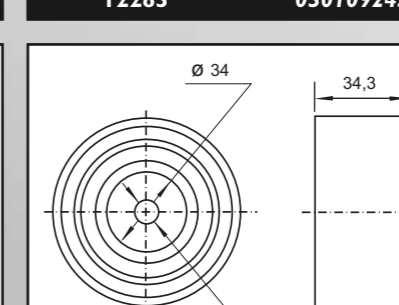
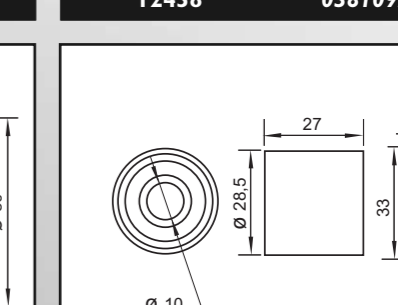
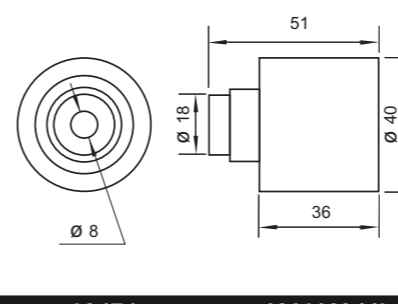
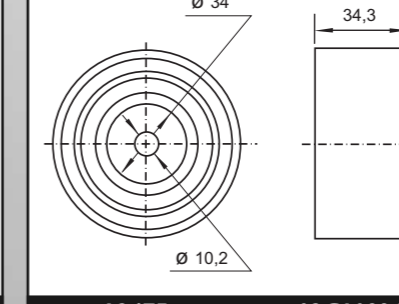
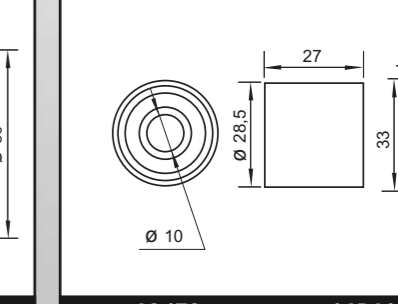
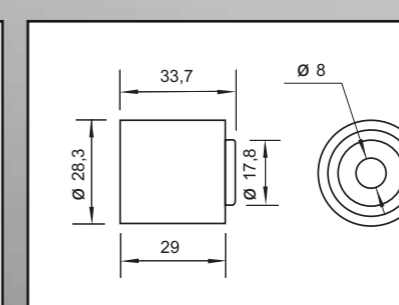
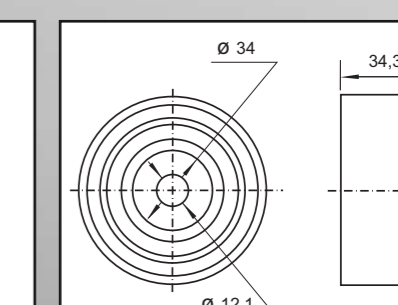
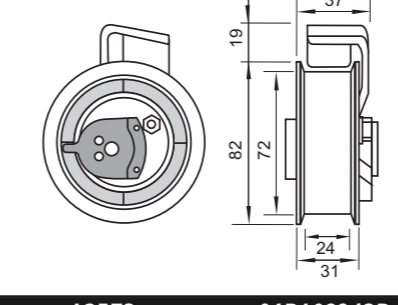
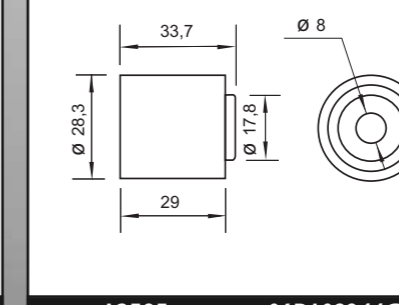
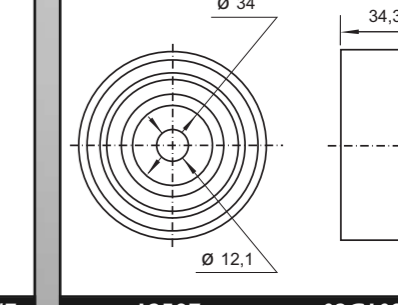
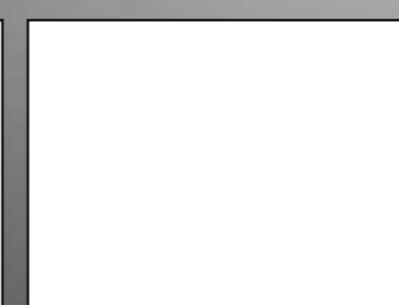
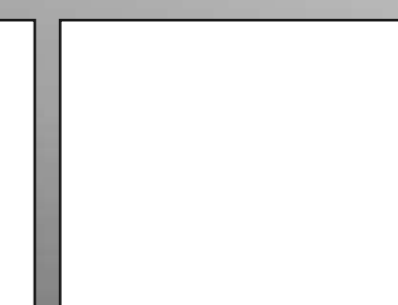
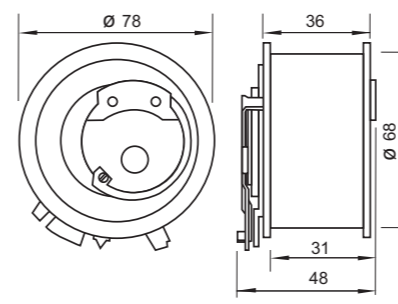
CÓDIGO CODE	CÓDIGO ORIGINAL ORIGINAL CODE	CÓDIGO CODE	CÓDIGO ORIGINAL ORIGINAL CODE	CÓDIGO CODE	CÓDIGO ORIGINAL ORIGINAL CODE
	1104		028109243F		1128
					028109244
			1805		026109243A
	1806		068109243C		12283
					030109243J
			12458		038109243M
	12474		038109244J		12475
					03G109244
			12478		06B109244
	12573		06B109243B		12595
					06B109244C/D/E
			12597		03G109244A
	12598				03G109243

MODELO MODEL	COMB. / FUEL	MOTOR ENGINE	AÑO YEAR		CÓDIGO CODE EM euromotor®		
			DESDE SINCE	HASTA TO	FIJO FIXED	MÓVIL MOBILE	NOTA NOTE

Utilitarios

VOLKSWAGEN BUS

		N		1970			1805	Desde From 1600cc a 2100cc
2.5	2461	N	ACU - AEN	11/90			12241	Desde motor From engine 019150
2.5	2461	N	AET - AEU	08/96			12241	
1.6 D	1588	D	CS-JX	01/81	07/92		1806	
1.6 TD	1588	D	CS-JX	01/81	07/92		1806	
1.7 D	1716	D	KY	07/86	07/92		1806	
1.9 D	1896	D	IX	07/90			1806	
1.9 D	1896	D	IX	07/90			1104	Desde motor From engine 120078
1.9 TD	1896	D	ABL	10/92			1806	
1.9 TD	1896	D	ABL	10/92			1104	Desde motor From engine 029320
2.4 D	2370	D	AJA - AAB				12241	
2.5 SDi	2461	D	AGX	07/96			12241	
2.5 TDi	2461	D	ACV	09/95			12241	
2.5 TDi	2461	D	AJT - AHY	05/98			12241	

VOLKSWAGEN CADDY

1.4	1390	N	AEX	11/95	11/97		12283	
1.4	1391	N	AFX - I F - AEE	11/95		12438	12283	
1.4	1390	N	AKV	12/97			12283	
1.4	1390	N	APQ	12/97			12283	
1.4 16v	1390	N	APE	08/00		12438 12440	12549 12550	
1.5	1457	N	JB	01/82	07/83		1805	
1.5	1457	N		08/82	07/92		1805	
1.6	1595	N	EM - EW - HN	01/82	07/92		1805	
1.6	1595	N	IF	11/95	05/97		1805	

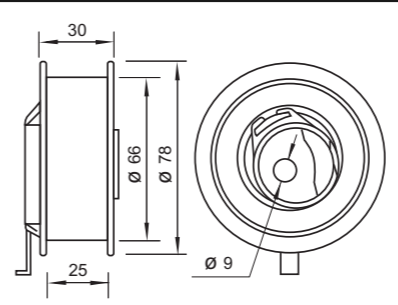
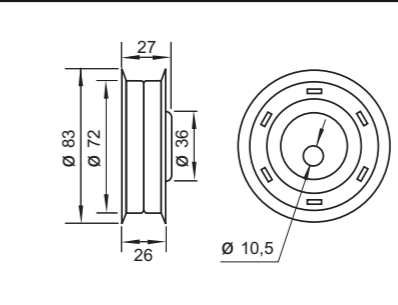
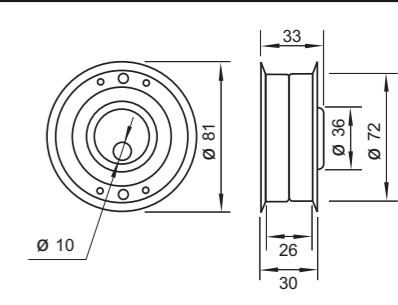
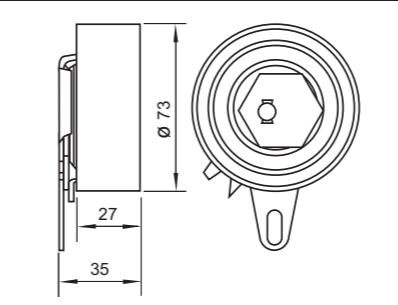
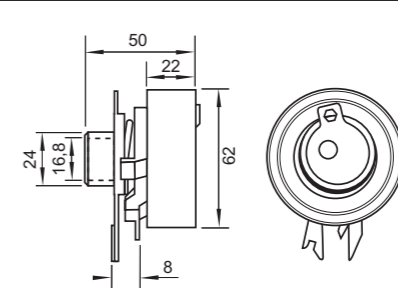
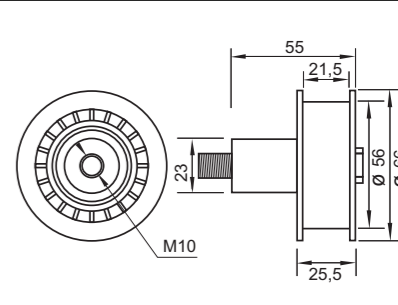
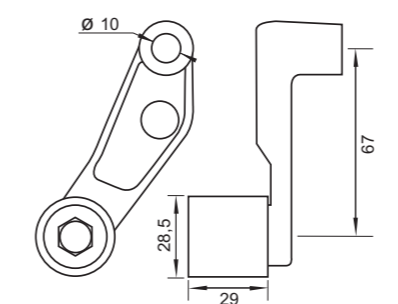
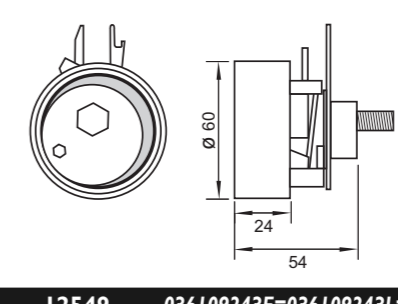
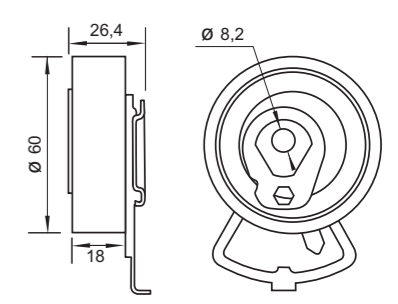
CÓDIGO CODE EM	CÓDIGO ORIGINAL ORIGINAL CODE	CÓDIGO CODE EM	CÓDIGO ORIGINAL ORIGINAL CODE	CÓDIGO CODE EM	CÓDIGO ORIGINAL ORIGINAL CODE
	028109243F		026109243A		068109243C
	074109243F		030109243J		036109244D
	036109181A		036109243E=036109243L= 036109243R=036109243AB		036109243S

MODELO MODEL	COMB./FUEL	MOTOR ENGINE	AÑO YEAR		CÓDIGO CODE		
			DESDE SINCE	HASTA TO	FIJO FIXED	MÓVIL MOBILE	NOTA NOTE

CÓDIGO CODE	EM	CÓDIGO ORIGINAL ORIGINAL CODE	CÓDIGO CODE	EM	CÓDIGO ORIGINAL ORIGINAL CODE	CÓDIGO CODE	EM	CÓDIGO ORIGINAL ORIGINAL CODE
----------------	----	----------------------------------	----------------	----	----------------------------------	----------------	----	----------------------------------

VOLKSWAGEN CADDY

1.6	1598	N	AEE	12/97				12283	
1.6	1595	N		08/82	07/92			1805	
1.6	1598	N	AFX - I F - AEE	11/95		12438		12283	
1.8	1781	N		08/82	07/92			1805	
1.6 D	1589	D	JK-ME	08/90	07/92			1806	
1.7 SDi	1699	D	AHB	10/96		1128	1104		
1.7 SDi	1699	D	AY - AEY	11/95		1128	1104		
1.9 D	1896	D	AEF	10/97				1104	
1.9 D	1896	D	AEF - AEY	11/95		1128	1104		
1.9 D	1896	D	AEF - AEY	11/95		1167	1107		
1.9 SDi	1896	D	AEF - AEY	11/95		1128	1104		
1.9 SDi	1896	D	AEF - AEY	11/95		1167	1107		
1.9 TDi	1896	D	AHU	09/96		1128	1104		
1.9 TDi	1896	D	ALE	09/97		1128	1104		
1.9 TDi	1896	D	AHU - ALE	09/96		1128	1104		

VOLKSWAGEN CARAVELLE

1.6 D	1588	D	CS - JX	01/81	07/92			1806	
1.6 TD	1588	D	CS - JX	01/81	07/92			1806	
1.7 D	1716	D	KY	07/86	07/92			1806	
1.9 D	1896	D	KY	07/86	07/92			1806	
1.9 TD	1896	D	KY	07/86	07/92			1806	

VOLKSWAGEN LT

1.6	1595	N		1975	06/96			1805	
2.5 TDi	2461	D	ANJ - APA	05/99				12580 12578 12319	
2.5 TDi	2461	D	AGX - AHD	05/96				12580 12578 12319	

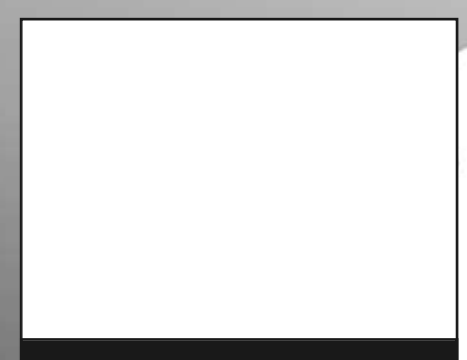
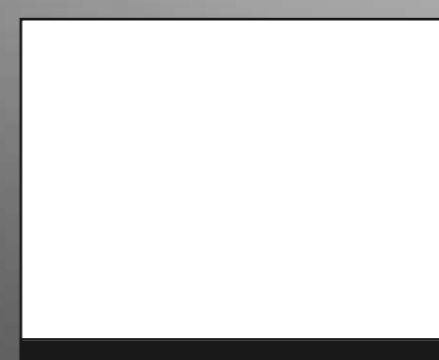
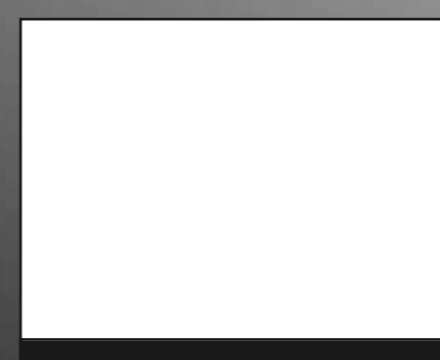
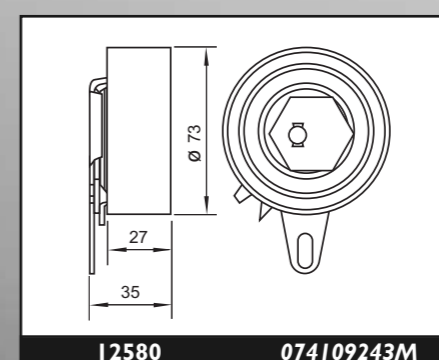
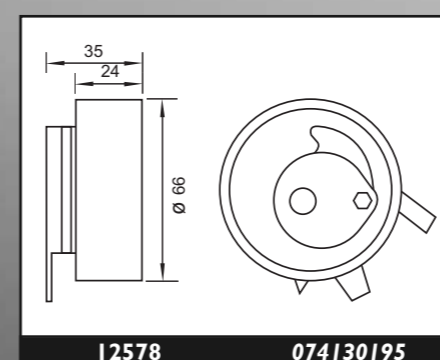
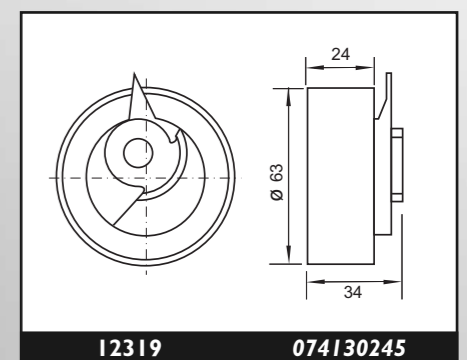
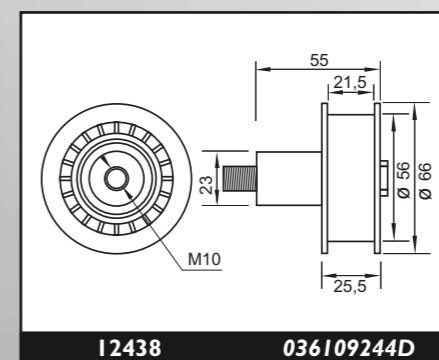
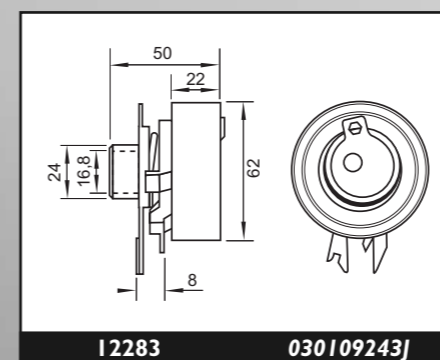
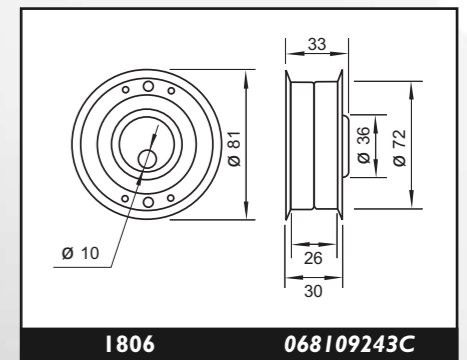
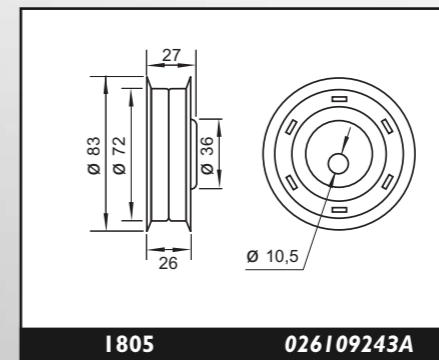
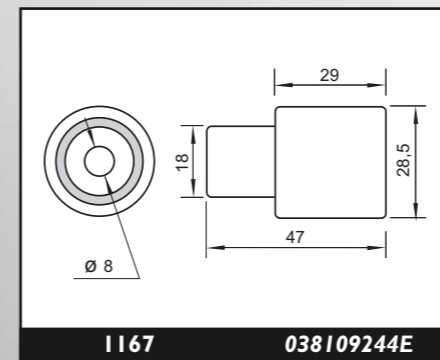
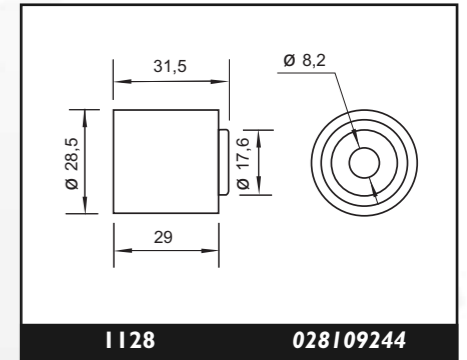
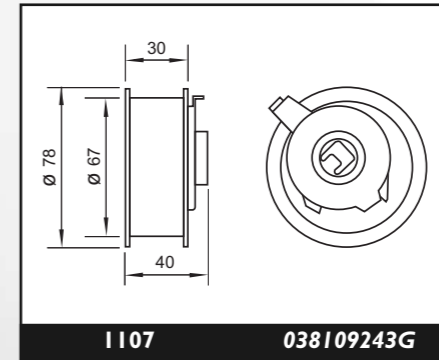
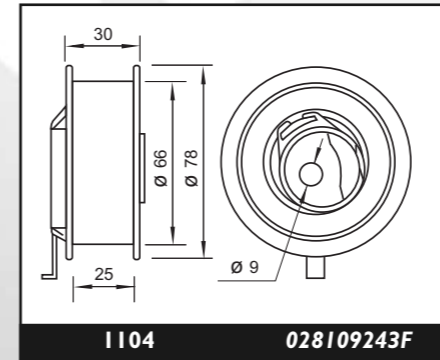

VOLKSWAGEN

VOLKSWAGEN

MODELO MODEL	COMB./FUEL	MOTOR ENGINE	AÑO YEAR		CÓDIGO CODE			NOTA NOTE
			DESDE SINCE	HASTA TO	FIJO FIXED	MÓVIL MOBILE	EM euromotor®	

VOLKSWAGEN TARO

2.4 D	2383	D	2L	06/89		1014	1013	
-------	------	---	----	-------	--	------	------	--

VOLKSWAGEN TRANSPORTER

2.0	1984	N	AAC	09/90			1805	
2.5	2461	N	AAF	06/90		52004	12580	
2.5	2461	N	ACU	06/90		52004	12580	
2.5	2461	N	AEN	02/95	12/95	52004	12580	
2.5	2461	N	APL	01/98		52004	12580	
2.5	2461	N	AUT	01/98		52004	12580	
1.6 D	1588	D	CS	01/81	12/87		1806	
1.6 D	1588	D	JX	01/84	12/92		1806	
1.7 D	1716	D	KY	01/86	12/92		1806	
1.9 D	1896	D	IX-ABL	01/90		1128	1806	Desde motor From engine 029320
1.9 D	1896	D	IX	01/90		1128	1104	Desde motor From engine 029320
1.9 D	1896	D	ABL	12/92		1128	1104	Desde motor From engine 120078
1.9	1896	D	AXC AXB BRS	02/08		12474	12458	
2.4 D	2370	D	AAB	01/90		52004	12241 12319	
2.5 TDi	2461	D	ACV	01/90		52004	12241 12319	
2.5 TDi	2461	D	AJT	05/98		12578	12241 12319	
2.5 TDi	2461	D	AUF	05/98		12578	12580 12319	
2.5 TDi	2461	D	AHY	01/99		12578	12580 12319	

CÓDIGO CODE	EM	CÓDIGO ORIGINAL ORIGINAL CODE	CÓDIGO CODE	EM	CÓDIGO ORIGINAL ORIGINAL CODE	CÓDIGO CODE	EM	CÓDIGO ORIGINAL ORIGINAL CODE
1013		J1350354021	1014		J1350354030	1104		028109243F
1128		028109244	1805		026109243A	1806		068109243C
12241		074109243E	12319		074130245	12458		038109243m
12474		038109244j	12578		074130195	12580		074109243M
52004		069109243B						

VOLKSWAGEN

VOLKSWAGEN

EM euromotor®

VERSION PDF 2010



$\varnothing 18$

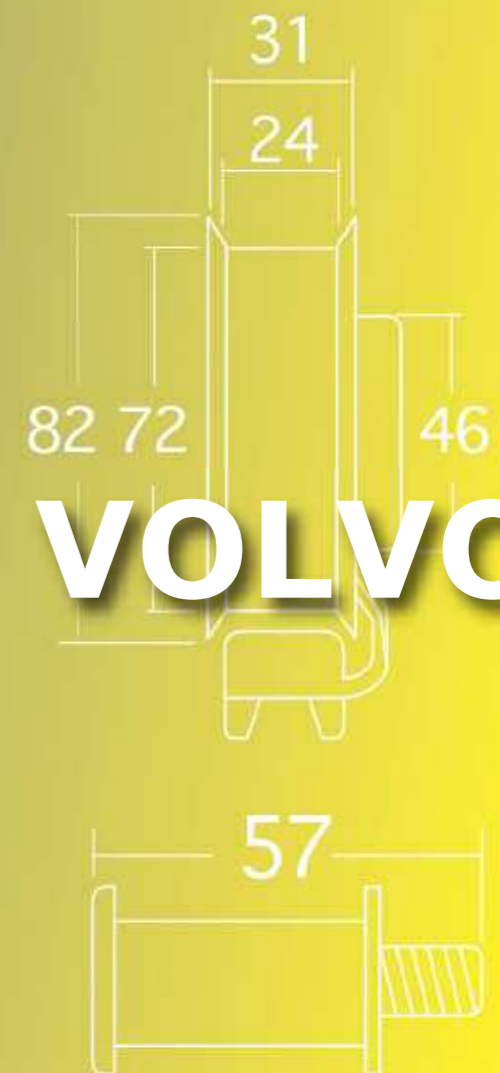

VOLVO



MODELO MODEL	AÑO YEAR	MOTOR ENGINE	CÓDIGO CODE			NOTA NOTE
			DESDE SINCE	HASTA TO	EM euromotor®	

CÓDIGO CODE	EM	CÓDIGO ORIGINAL ORIGINAL CODE	CÓDIGO CODE	EM	CÓDIGO ORIGINAL ORIGINAL CODE	CÓDIGO CODE	EM	CÓDIGO ORIGINAL ORIGINAL CODE
----------------	----	----------------------------------	----------------	----	----------------------------------	----------------	----	----------------------------------

VOLVO 240

B17	1700	N	B17					12587
2.4 D	2385	D	D24			52004		

VOLVO 242

B19	1900	N	B19					12587
-----	------	---	-----	--	--	--	--	-------

VOLVO 244

B20	2000	N	B20					12587
-----	------	---	-----	--	--	--	--	-------

VOLVO 245

B23	2300	N	B23					12587
-----	------	---	-----	--	--	--	--	-------

VOLVO 246

2.4 D	2385	D	D24			52004		
-------	------	---	-----	--	--	-------	--	--

VOLVO 260

2.4 D	2385	D	D24			52004		
-------	------	---	-----	--	--	-------	--	--

VOLVO 340

1.7	1721	N	B172K	08/85	07/91			1865
2.0	1986	N	B19-B200	08/82	07/91			12587
1.6 D	1596	D	D16	08/84	01/88	12582		12581
1.6 D	1596	D	D16	02/88	07/91			1865

VOLVO 360

1.7	1721	N	B172K	08/85	07/91			1173
2.0	1986	N	B19-B200	08/82	07/91			12587
1.6 D	1596	D	D16	08/84	01/88	12582		12581
1.6 D	1596	D	D16	02/88	07/91			1173

VOLVO 440

1.6	1596	N	B16F	09/88	12/96			1865
-----	------	---	------	-------	-------	--	--	------

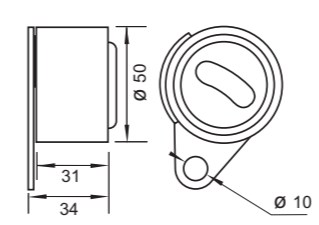
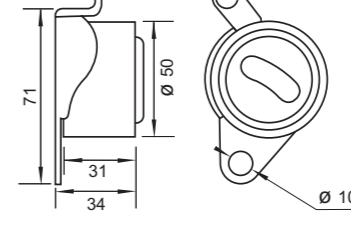
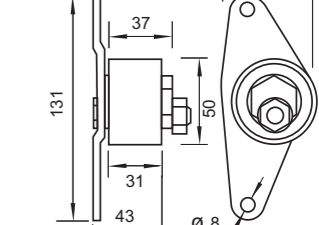
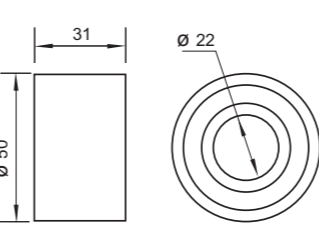
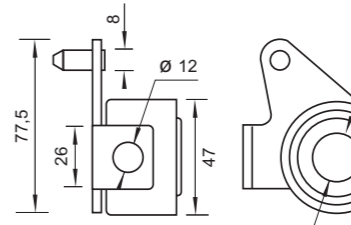
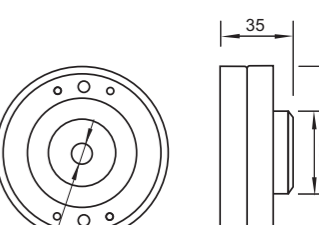
 <p>1173 38855993</p>	 <p>1865 3343741</p>	 <p>12581 3287773=3342143</p>
 <p>12582 3287776-3=3342134</p>	 <p>12587 463633=463638-8</p>	 <p>52004 1257118=1257120</p>

VOLVO

VOLVO

MODELO MODEL	COMB./ FUEL	MOTOR ENGINE	AÑO YEAR		CÓDIGO CODE EM euromotor®		
			DESDE SINCE	HASTA TO	FIJO FIXED	MÓVIL MOBILE	NOTA NOTE

VOLVO 440

1.7		N	B18	09/88	12/96		1173	
1.7 Turbo		N	B18	09/88	12/96		1173	
1.8		N	B18U	08/91	07/96		1173	
2.0		N	B20F	08/92	09/96		1173	
1.9TD		D	D19T	07/94	12/96		1173	

VOLVO 460

1.6		N	B16F	09/88	12/96		1173	
1.7		N	B18	09/88	12/96		1173	
1.7 Turbo		N	B18	09/88	12/96		1173	
1.8		N	B18U	08/91	07/96		1173	
2.0		N	B20F	08/92	09/96		1173	
1.9TD		D	D19T	07/94	12/96		1173	

VOLVO 480

1.7		N	B18	04/86	07/96		1173	
1.7		N	B18	04/86	07/96		1173	Desde motor From engine 16530
1.7 Turbo		N	B18FT	08/87	07/96	12582	12581	
1.7 Turbo		N	B18FT	08/87	07/96		1173	Desde motor From engine 1456
2.0		N	B20F	08/92	09/95		1173	

VOLVO 740

2.0		N	B200F	08/83	08/92		12587	
2.0		N	N2H - N2P			12200 12200		Motor Engine 5 a 6 cil.
2.0		N	B204		1990	12584 12583 12585		
2.0		N	B204	1991		12583 12585		
2.4 D		D	D24	09/85	07/92	52004 12589		

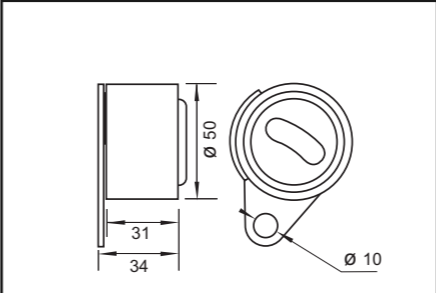
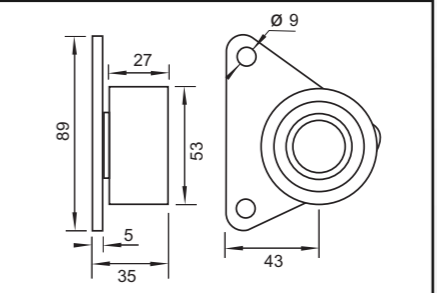
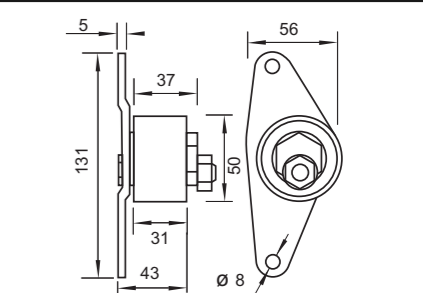
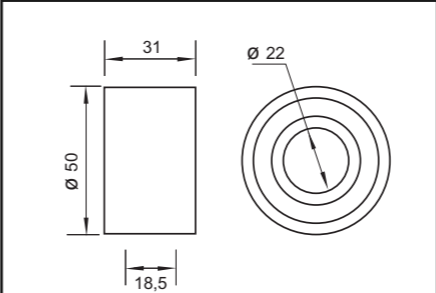
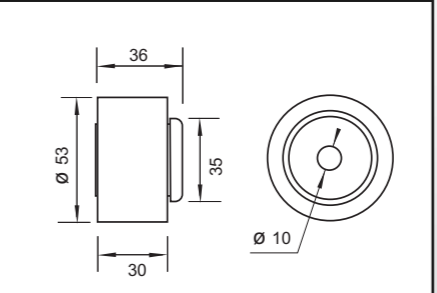
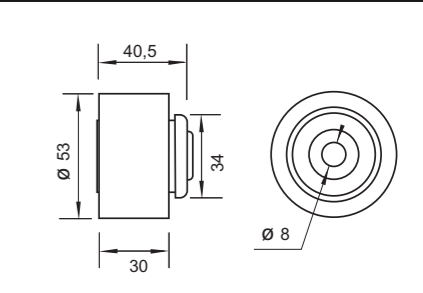
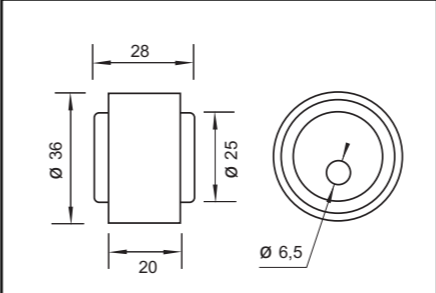
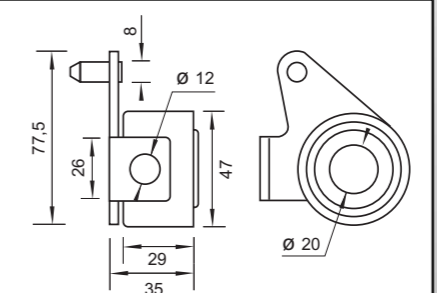
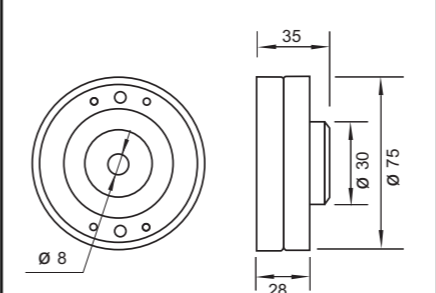
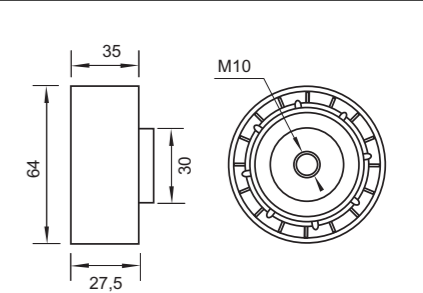
CÓDIGO CODE EM	CÓDIGO ORIGINAL ORIGINAL CODE	CÓDIGO CODE EM	CÓDIGO ORIGINAL ORIGINAL CODE	CÓDIGO CODE EM	CÓDIGO ORIGINAL ORIGINAL CODE
	1173	38855993		12200	8630590=9146376
	12581	3287773=3342143		12582	3287776-3=3342134
	12583	3531279=3531278-2		12584	1326284=1326284-5
	12585	1357936=1357936-2		12587	463633=463638-8
	52004	1257118=1257120		12589	9135946

VOLVO

VOLVO

MODELO MODEL	COMB./FUEL	MOTOR ENGINE	AÑO YEAR		CÓDIGO CODE EM euromotor®		
			DESDE SINCE	HASTA TO	FIJO FIXED	MÓVIL MOBILE	NOTA NOTE

VOLVO 760

2.0	1986	N	B200F	08/83	08/92		12587	
2.0	1986	N	N2H - N2P				12589 12589	Motor Engine 5 a 6 cil.
2.0	1986	N	B204		1990		12584 12583 12585	
2.0	1986	N	B204	1991			12583 12584	12585
2.4 D	2383	D	D24	09/85	07/92		52004 12200	

VOLVO 780

2.0	1986	N	B204		1990		12584 12583 12585	
2.0 Turbo	1986	N	B200	1985	1990			12587 Desde From 1700cc a 2300cc
2.0 Turbo	1986	N	N2H - N2P		12/90		12589 12589	Motor Engine 5 a 6 cil.
2.0 Turbo	1986	N	B200 - B204	01/91			12583 12584	12585
2.4 TD	2383	D	D24T	1984			52004 12589	

VOLVO 850

2.0 10v	1984	N	B5202 - B5202S	08/94	12/96		12199 12200	1930 Hasta motor Up to engine 131034
2.0 20v	1984	N	B5204F - B5204T	08/94	12/96		12199 12200	1930 Desde motor From engine 131035
2.3 T5	2319	N	B5234FT	08/94	12/96		12199 12200	1930 Desde motor From engine 131035
2.5 10v	2435	N	B5252	08/94	12/96		12199 12200	1930 Hasta motor Up to engine 131034
2.5 20v	2435	N	B5254S - B5254T	08/94	12/96		12199 12200	1930 Desde motor From engine 131035
2.5 TDi	2461	D	D5252T	08/95			12319 12590	12580 12578 Bomba inyectora Injection pump

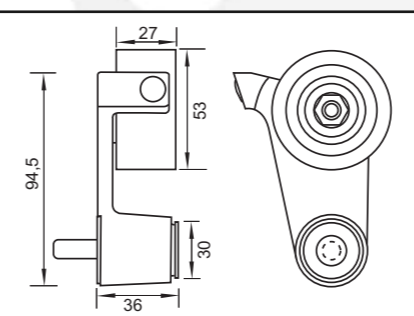
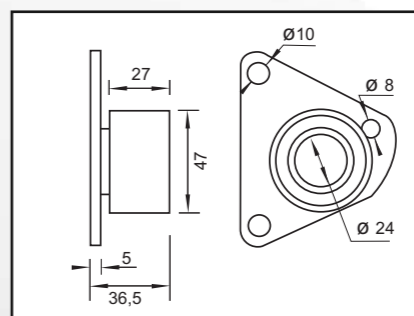
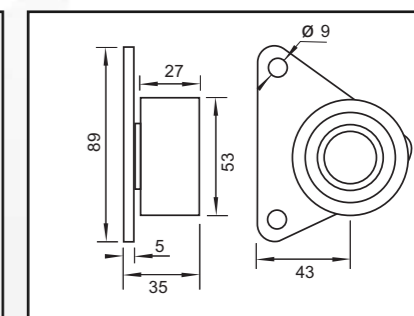
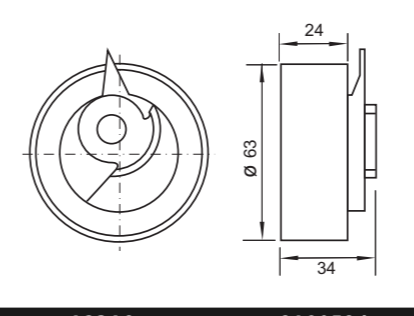
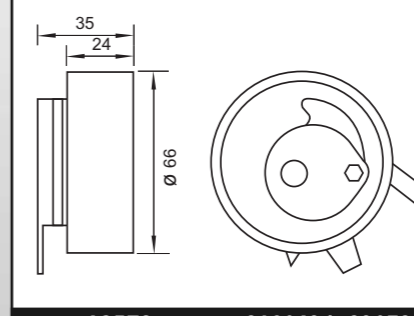
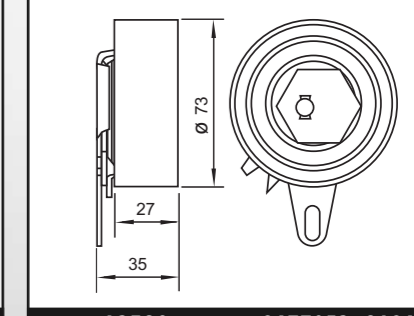
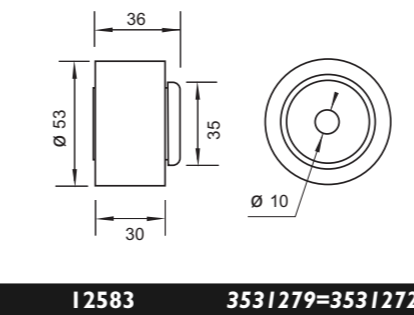
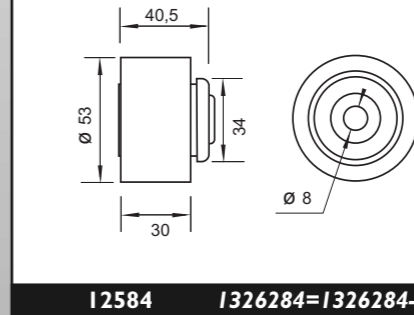
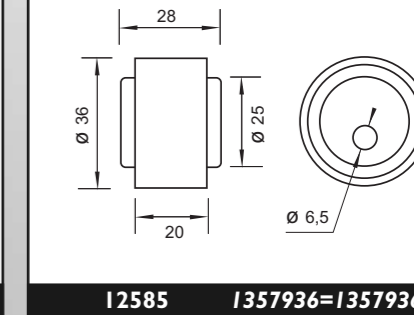
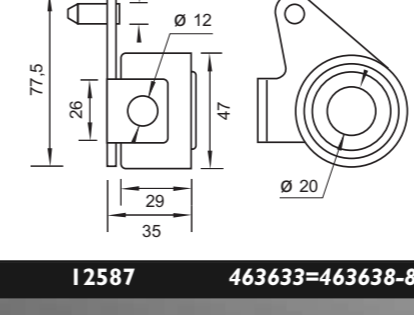
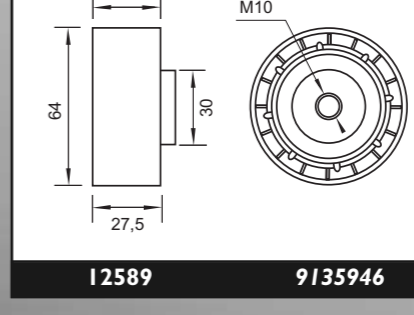
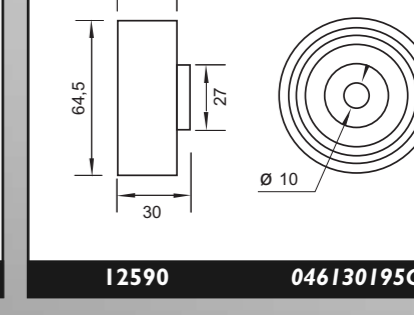
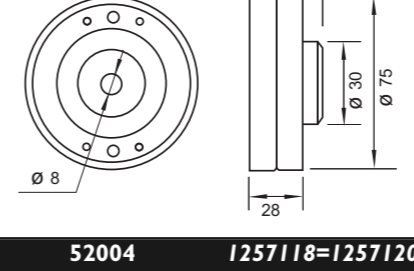
CÓDIGO CODE EM	CÓDIGO ORIGINAL ORIGINAL CODE	CÓDIGO CODE EM	CÓDIGO ORIGINAL ORIGINAL CODE	CÓDIGO CODE EM	CÓDIGO ORIGINAL ORIGINAL CODE
					
1930	7439135036	12199	6842125=9146258	12200	8630590=9146376
					
12319	9180594	12578	9180624=9207927	12580	8677053=9186258
					
12583	3531279=3531272	12584	1326284=1326284-5	12585	1357936=1357936-2
					
12587	463633=463638-8	12589	9135946	12590	046130195C
					
52004	1257118=1257120				

VOLVO

VOLVO

MODELO MODEL	COMB./FUEL	MOTOR ENGINE	AÑO YEAR		CÓDIGO CODE EM euromotor®		
			DESDE SINCE	HASTA TO	FIJO FIXED	MÓVIL MOBILE	NOTA NOTE

VOLVO 940

2.0		N	B200F	02/92	07/94			12587	
2.0		N	B204	01/95			12198	1930	6 cil.
2.3		N	B204	01/95			12198	1930	6 cil.
2.0		N	B204	1991			12583 12584	12585	
2.3	2316	N	B234	1991			12583 12584	12585	

VOLVO 960

2.0		N	B200F	02/92	07/94			12587	
2.0		N	B204	01/95			12198	1930	6 cil.
2.0		N	B204	1991			12583 12584	12585	
2.3		N	B204	01/95			12198	1930	6 cil.
2.5	2473	N	B6254S	1994			12200 12200 12198	1930	
3.0 24v	2988	N	B6304S	1994			12200 12200 12198	1930	

VOLVO S40

1.6 16v	1587	N	B4164S	01/96	2003	12200	1930	Hasta motor Up to engine 1219110
1.6 16v	1587	N	B4164S	01/96	2003	12200	1137	Desde motor From engine 1219111
1.8 16v	1731	N	B4184S	01/96	12/97	12200	1930	Hasta motor Up to engine 1219110
1.8 16v	1731	N	B4184S	01/96	12/97	12200	1137	Desde motor From engine 1219111
1.8i 16v	1783	N	B4184SM	03/98	2003	1055	12226	Motor Mitsubishi Engine
1.9 16v	1855	N	B4194T	05/97	2003	12200	1930	Hasta motor Up to engine 1219110
1.9 16v	1855	N	B4194T	05/97	2003	12200	1137	Desde motor From engine 1219111
2.0 16v	1984	N	B4205S-T	01/96	12/97	12200	1930	Hasta motor Up to engine 1219110

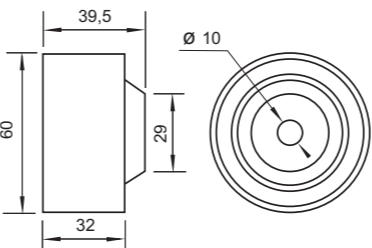
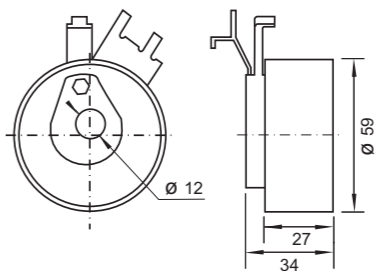
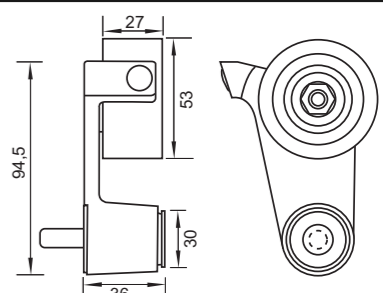
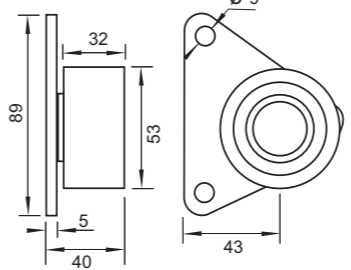
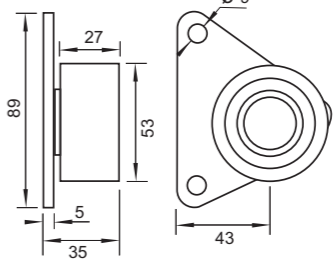
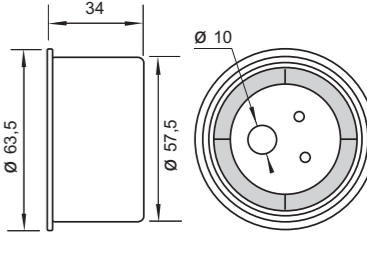
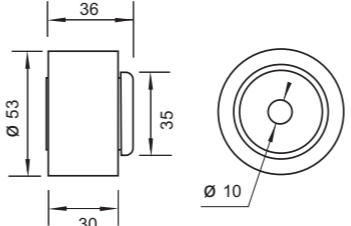
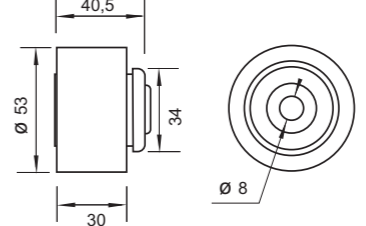
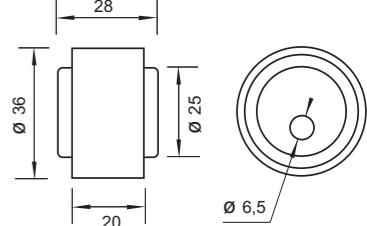
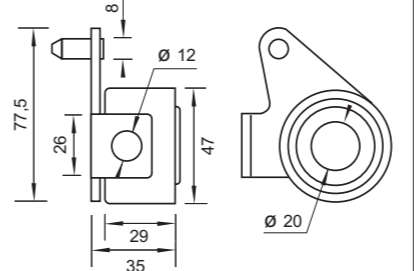
CÓDIGO CODE EM	CÓDIGO ORIGINAL ORIGINAL CODE	CÓDIGO CODE EM	CÓDIGO ORIGINAL ORIGINAL CODE	CÓDIGO CODE EM	CÓDIGO ORIGINAL ORIGINAL CODE
	30874227		9440329=8642251		7439135036
1055		1137		1930	
	9135556		8630590=9146376		30873954
12198		12200		12226	
	3531279=3531278-2		1326284=1326284-5		1357936=1357936-2
12583		12584		12585	
	463633=463638-8				
12587					

MODELO MODEL	AÑO YEAR	MOTOR ENGINE	CÓDIGO CODE		FIJO FIXED	MÓVIL MOBILE	NOTA NOTE
			DESDE SINCE	HASTA TO			

VOLVO S40

2.0 16v T.	1984	N	B4205S-T	01/96	12/97	12200	1137	Desde motor From engine 1219111
1.9TD	1870	D	D4192T	07/95	06/99	1854 1153	1173	
1.9TD	1870	D	D4192T	07/95	06/99	12606 1153	1173	Hasta motor Up to engine 20560
1.9 DI	1870	D	D4192T2	03/99	07/00	1148 1153	1173	
2.0 D	1997	D	D4204T2	01/04		12507	12522	Motor Peugeot Engine

VOLVO V40

1.6 16v	1587	N	B4164S	01/96	2003	12200	1930	Hasta motor Up to engine 1219110
1.6 16v	1587	N	B4164S	01/96	2003	12200	1137	Desde motor From engine 1219111
1.8 16v	1731	N	B4184S	01/96	12/97	12200	1930	Hasta motor Up to engine 1219110
1.8 16v	1731	N	B4184S	01/96	12/97	12200	1137	Desde motor From engine 1219111
1.8i 16v	1783	N	B4184SM	03/98	2003	1055	12226	Motor Mitsubishi Engine
1.9 16v	1855	N	B4194T	05/97	2003	12200	1930	Hasta motor Up to engine 1219110
1.9 16v	1855	N	B4194T	05/97	2003	12200	1137	Desde motor From engine 1219111
2.0 16v	1984	N	B4205S-T	01/96	12/97	12200	1930	Hasta motor Up to engine 1219110
2.0 16v	1984	N	B4205S-T	01/96	12/97	12200	1137	Desde motor From engine 1219111
1.9 TD	1870	D	D4192T	07/95	06/99	1854 1153	1173	
1.9TD	1870	D	D4192T	07/95	06/99	12606 1153	1173	Desde motor From engine 20560
1.9 DI	1870	D	D4192T2	03/99	07/00	1148 1153	1173	

VOLVO V50

2.0 D	1997	D	D4204T2	03/04		12507	12522	Motor Peugeot Engine
-------	------	---	---------	-------	--	-------	-------	----------------------

CÓDIGO CODE	EM	CÓDIGO ORIGINAL ORIGINAL CODE	CÓDIGO CODE	EM	CÓDIGO ORIGINAL ORIGINAL CODE	CÓDIGO CODE	EM	CÓDIGO ORIGINAL ORIGINAL CODE
1055		30874227	1137		9440329=8642251	1148		8642248
1153		30750739=30864050	1173		38855993	1854		3343740
1930		7439135036	12200		8630590=9146376	12226		30873954
12507		8653652	12522		8653651	12606		30855992

VOLVO

VOLVO

MODELO MODEL	AÑO YEAR	MOTOR ENGINE	CÓDIGO CODE			FIJO FIXED	MÓVIL MOBILE	NOTA NOTE
			DESDE SINCE	HASTA TO	EM euromotor®			

VOLVO S60

2.0T	1984	N	B5204T5	10/00		12200	1137	
2.3T	2319	N	B5234T3	10/00		12200	1137	
2.4 20v - T	2435	N	B5234T3	10/00		12200	1137	

VOLVO C70

2.0T	1984	N	B5204T	01/97		12200	1930	Hasta motor Up to engine 1266127
2.3T	2319	N	B5234T-S	01/97		12200	1930	
2.5	2498	N	B5254T	01/99		12200	1137	Desde motor From engine 1266128

VOLVO S70

2.0T	1984	N	B5204T	01/97		12200	1930	Hasta motor Up to engine 1266127
2.5 D	2461	D	D5252	01/97			12319 12580 12578	Bomba inyectora Injection pump

VOLVO V70

2.0	1984	N	B5202S	01/97		12200	1930	Hasta motor Up to engine 1266127
2.0 - 2.0T	1984	N	B5202S-T	01/97		12200	1137	Desde motor From engine 1266128
2.3T - 2.4 20v	2319	N	B5234T	01/97		12200	1930	Hasta motor Up to engine 1266127
2.3T - 2.4 20v	2319	N	B5234T	01/97		12200	1137	Desde motor From engine 1266128
2.5	2498	N	B5254T	01/99		12200	1137	
2.5 D	2461	D	D5252	01/97			12319 12580 12578	Bomba inyectora Injection pump
2.5 TDI	2461	D	D5252T	01/00		12590	12319 12580 12592	Bomba inyectora Injection pump

VOLVO S80

2.0 - 2.0T	1984	N	B5204T3	01/99		12200	1137	
------------	------	---	---------	-------	--	-------	------	--

CÓDIGO CODE	EM	CÓDIGO ORIGINAL ORIGINAL CODE	CÓDIGO CODE	EM	CÓDIGO ORIGINAL ORIGINAL CODE	CÓDIGO CODE	EM	CÓDIGO ORIGINAL ORIGINAL CODE
1137		9440329=8642251	1930		7439135036	12200		8630590=9146376
12319		9180594	12578		9180624=9207927	12580		8677053=9186258
12590		046130195C	12592		4277048=4320893			

VOLVO

VOLVO

MODELO MODEL	COMB./FUEL	MOTOR ENGINE	AÑO YEAR		CÓDIGO CODE EM euromotor®		
			DESDE SINCE	HASTA TO	FIJO FIXED	MÓVIL MOBILE	NOTA NOTE

VOLVO S80

2.4 20v	2435	N	B5244S	01/99		12200	1930	Hasta motor Up to engine 1266127
2.4 20v	2435	N	B5244S	01/99		12200	1137	Desde motor From engine 1266128
2.5 TDI	2461	D	D5252T	01/99			12319 12580 12578	Bomba inyectora Injection pump

VOLVO S90

2.0	1984	N	B200	01/95			12587	
2.3	2319	N	B230	01/95			12587	
3.0 24v	2922	N	B6304	01/95		12198		

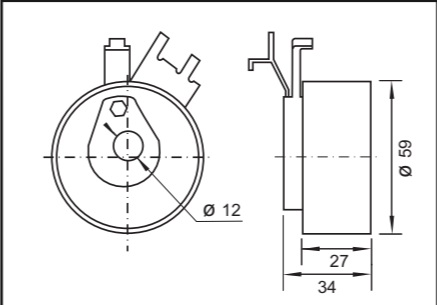
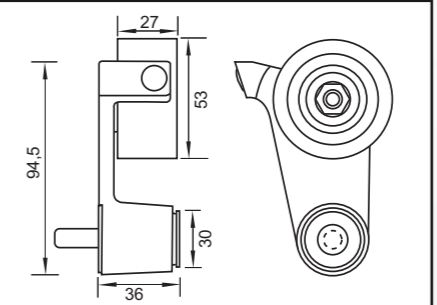
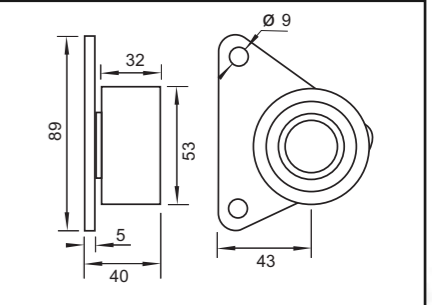
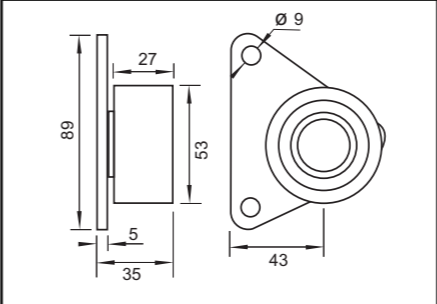
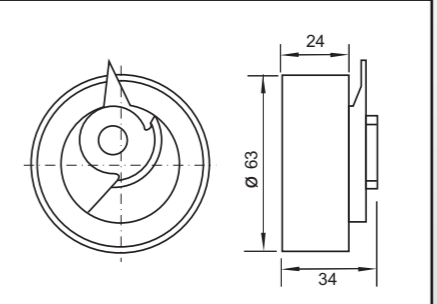
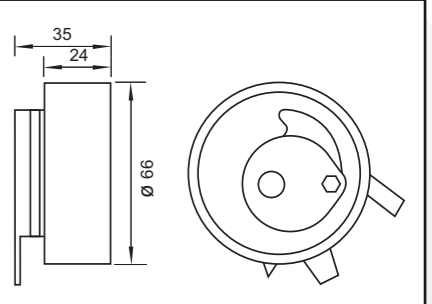
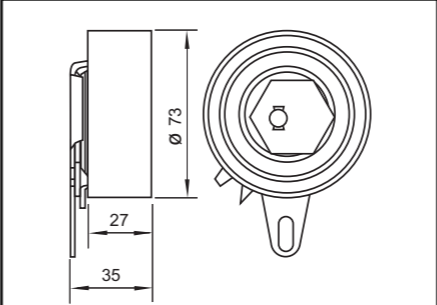
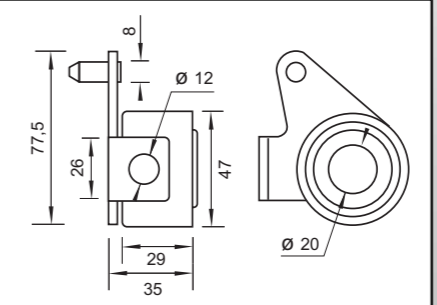
CÓDIGO CODE EM	CÓDIGO ORIGINAL ORIGINAL CODE	CÓDIGO CODE EM	CÓDIGO ORIGINAL ORIGINAL CODE	CÓDIGO CODE EM	CÓDIGO ORIGINAL ORIGINAL CODE
	9440329=8642251		7439135036		9135556
1137		1930		12198	
	8630590=9146376		9180594		9180624=9207927
12200		12319		12578	
	8677053=9186258		463633=463638-8		
12580		12587			

EM euromotor®

VERSION PDF 2010

EQUIVALENCIAS
CROSS REFERENCES



CÓDIGO ORIGINAL ORIGINAL CODE

CÓDIGO ORIGINAL ORIGINAL CODE

CÓDIGO ORIGINAL ORIGINAL CODE

CÓDIGO ORIGINAL ORIGINAL CODE

CÓDIGO ORIGINAL ORIGINAL CODE

CÓDIGO ORIGINAL ORIGINAL CODE

ALFA ROMEO

534134	1800-MI
534135	1801-MI
633254	12153-M
5970621	1889-M
5997325	1818-M
7541718	1832-MD
7541718	1832-MI
7554724	3216-P
7596727	1889-M
7596727	1889-MI
7596728	1835-M
7596728	1835-MI
7596876	1889-M
7596877	1835-M
7596877	1835-MI
7702173	1187-PI
7763644	1950-MI
7766487 (amortiguador solo / shock absorber only)	12350-AMO
7766585 (amortiguador solo / shock absorber only)	12350-AMO
46424716	1187-PI
46432124	1187-PI
46460702 (amortiguador solo / shock absorber only)	12350-AMO

46544419	3206-PI
46524692	12353-AI
46546374	12352-AI
46547564	12038-P
46547566	12357-PI
46794035	3206-PI
55180011	12353-AI
60621380	12354-AI
60504224	1800-FLEN
60504224	1800-MI
60504225	1801-FLEN
60504225	1801-MI
60504226	1937-FLEN
60504226	1937-PI
60537975	1938-MI
60561614	12041-P
60580235	12153-M
60596372	12090-A
60596372	12090-AI
60607965	1938-MI
60610908	3201-AL
60610908	3201-PI
60620443 (enr. árbol contrarrotante / balance shaft)	12315-AI

60621380	12354-AI
60652129	1938-MI
60652477	12354-AI
60654130	12356-PI
60654130	
(reparación / repair)	12038-P
60664403	12204-MI
60671573	12204-MI
60805460	1187-AL
60805460	1187-PI
60808692	1889-M
60808692	1889-MI
60810644	12152-M
60813311	12152-M
60813590	1950-MI
60814033	3206-PI
60814110	12353-AI
60814462	12354-AI
60814917	12357-PI
73501924	3201-AL
73501924	3201-PI
96284314	12095-M
99482225	12285-PML

AUDI

026 109 243	1805-M
026 109 243A	1805-M
026 109 243C	1805-M
026 109 243E	1805-M
026 109 243L	1805-M
027 109 243	1808-M
028 109 243AF	1104-A
028 109 243AF	1104-AI
028 109 243E	1104-A
028 109 243F	1104-A
028 109 244	1128-FLEN
028 109 244	1128-MI
028 109 244	1128-M
028 903 119AC	12286-PML
028 903 119AM	12287-PML
028 903 315R	FA-99048
030 145 299C	12450-AI
030 145 299E	12450-AI
031 145 276	1174-AI
032 145 299A	12602-AI
032 145 299C	FA-20912
036 109 243AB	12549-AI
036 109 243AD	12549-AI
036 109 243E	12549-AI
036 109 243L	12549-AI
036 109 243R	12549-AI
038 109 243	1107-A
038 109 243D	1107-A

038 109 243F	1107-A
038 109 243G	1107-A
038 109 243H	1107-A
038 109 243M	12458-AI
038 109 243N	1107-A
038 109 244B	1166-M
038 109 244E	1167-M
038 109 244E	1167-MI
038 109 244J	12474-M
038 903 119M	12286-PML
038 903 119T	12287-PML
038 903 315A	FA-20907
038 903 315AE	FA-99049
038 903 315C	12361-AI
038 903 315D	12459-AI
038 903 315E	FA-20907
038 903 315F	FA-99049
038 903 315K	FA-20907
038 903 315P	12459-AI
038 903 315R	FA-99048
03G 109 243	12476-FLEN
03G 109 243M	12458-AI
03G 109 244	12596-M
045 109 243C	12239-AI
045 109 243F	12458-AI
045 109 244A	12238-FLEN
045 109 244A	12238-M
045 109 479B	FD-99004

045 109 479C	FD-99005
045 130 195B	12592-FLEN
046 130 195D	12590-FLEN
051 109 243	1808-M
051 109 243A	1129-FLEN
058 109 243B	1130-MI
058 109 244	1131-FLEN
058 109 244	1131-M
058 109 244	1131-MI
058 109 243C	12228-FLEN
058 109 243E	12228-FLEN
058 109 243F	12228-FLEN
058 109 243B	1130-MI
058 109 243C	12228-FLEN
058 109 243E	12228-FLEN
058 109 243F	12228-FLEN
058 109 244	1131-FLEN
058 109 244	1131-MI
058 109 479B	FD-99020
058 260 511	12362-MI
058 903 133	12256-AI
058 903 133B	12256-AI
058 903 133C	12256-AI
058 903 133D	12256-AI
058 903 341A	12605-M
059 109 243D	12570-FLEN
059 109 243J	12570-FLEN
059 109 244	12575-FLEN

AUDI

059 109 244A	12575-FLEN
059 109 244D	12575-FLEN
059 109 479B	FD-99003
059 109 487A	FA-99002
059 109 487B	FA-99002
059 109 487C	FA-99002
059 903 341A	12605-M
068 109 243	1806-M
068 109 243C	1806-M
068 109 243F	1806-M
06A 109 479	1157-AI
06A 109 479A	1157-AI
06A 109 479B	1157-AI
06A 109 479C	1157-AI
06A 903 315D	12258-AI
06A 903 315E	12258-AI
06B 109 243B	12573-FLEN
06B 109 243A	12240-NTN
06B 109 243D	12240-NTN
068 109 243C	1806-M

06B 109 244	12478-M
06B 109 477	12242-AI
06B 109 477A	12571-FLEN
06B 903 133	14033-FLEN
06B 903 133	FA99287
06B 903 133A	FA99287
06B 903 133E	FA99287
06C 109 244	12482-FLEN
06C 109 244C	12481-FLEN
06C 109 479A	FD-99021
06C 109 485A	12483-FLEN
6K0 145 299	FA-20912
074 109 243E	12580-FLEN
074 109 243G	12241-MI
074 109 243M	12580-FLEN
074 130 195	12578-FLEN
074 130 195B	12578-FLEN
077 109 243A	FS-99151
077 109 244A	FU-99152
077 109 244C	12576-FLEN

077 109 244E	12577-FLEN
077 109 485E	FS-99012
077 903 341	FU-99156
078 109 243Q	12480-MI
078 109 243R	12480-MI
078 109 244H	12479-FLEN
078 109 244J	12479-FLEN
078 109 479B	FD-99200
078 109 479D	FD-99022
078 109 479E	FD-99001
078 109 487A	FA-99014
078 903 133	14030-FLEN
078 903 133AB	12257-AI
078 903 133AB	
(reparación / repair)	22014-MI
078 903 133B	12257-AI
078 903 133T	12257-AI
078 903 341J	FU-20909
078 903 341J	14030-FLEN

BMW

11281 243510	FD-99146
11281 244424	FD-99146
11281 246769	FD-99146
11281 247647	FA-99123
11281 248168	FA-99146
11281 427252	FA-99138
11281 432104	FA-99123
11281 702013	14006-FLEN
11281 702013	FS-99183
11281 717188	FA-27994
11281 717210	FD-27995
11281 726181	FU-27992
11281 726343	12193-P
11281 730571	FU-27992
11281 735899	FA-99138
11281 736724	14004-FLEN
11281 736724	FS-99182

11281 738061	FU-27992
11281 738605	FU-27992
11281 742013	FS-99258
11281 742858	FS-99257
11281 747461	14006-FLEN
11281 747461	FS-99183
11281 748130	FU-27992
11281 748131	12193-P
11281 748832	FA-99138
11282 243592	FS-99121
11282 244754	FS-99121
11282 245087	12318-PI
11282 245166	FU-99112
11287 841228	FU-27992
11311 272424	12487-FLEN
11311 708806	12486-FLEN
11311 708806	FU-17990

11311 709646	12486-FLEN
11311 709646	FU-17990
11311 711153	12487-FLEN
11311 721245	12489-FLEN
11311 721245	FU-17999
11311 727141	12485-FLEN
11311 727141	FU17999
11311 721263	12489-FLEN
11311 721264	12485-FLEN
11311 726699	12318-PI
11311 727141	12485-FLEN
11311 727611	12488-FLEN
64551 726699	12318-PI
64551 748321	12318-PI
64552 244172	12318-PI
64552 244173	12318-PI

CHEVROLET

1340545	12253-INA
1340827	12172-AL
38001	62010-AL
5636415	1952-PI
5636416	1953-PI
5636419	1952-PI
5636425	1906-PI
5636426	1953-PI
5636427	1953-PI
5636429	1101-A
5636721	1948-A
5636738	1100-A
5636739	12457-A
5636740	12275-AI

636415	1906-PI
636420	12386-MI
636735	12384-MI
636725	1102-A
636726	1100-A
636727	1101-A
636730	1878-M
636730	1878-MI
636739	1102-A
8-94215197-1	12255-MI
90153123	1102-A
90153123	1102-AI
90153125	1100-A
90153125	1100-AI

90353176	1948-A
90353176	1948-AI
90354783	1948-A
90409238	3502-AL
90409238	3502-PI
94106001	1878-M
94106001	1878-MI
90411025	13108-A
90411025 (polea sola / pulley only)	62001-AL
90411769	1101-A
90411773	1907-AL
90411773	1907-MI
90411774	1100-A

A N° ORIGINAL

OE NUMBER

CÓDIGO ORIGINAL ORIGINAL CODE

CÓDIGO ORIGINAL ORIGINAL CODE

CÓDIGO ORIGINAL ORIGINAL CODE

CÓDIGO ORIGINAL ORIGINAL CODE

CÓDIGO ORIGINAL ORIGINAL CODE

CÓDIGO ORIGINAL ORIGINAL CODE

CHEVROLET

90411782	1906-PI
90411782	1906-PI
90411787	1909-FLEN
90411787	1909-MI
90412430	12266-AI
90412730	1953-PI
90412731	1952-PI
90412783	1102-A
90412884	12265-DAY
90412884	12265-AI
90499401	1948-A
90500124	1101-A
90500125	1100-A
90500229	12266-AI
90502129	12444-AI
90502421	12453-INA
90502421 (polea sola / pulley only)	12247AL
90528200	1101-A
90529810	1127-AL
90529810	1127-AL
90530123	1102-A
90571758	12267-AI
90571758 (polea sola / pulley only)	22014-MI
9128516	1102-A

9128656	1102-A
9128736	1906-PI
9128738	1906-PI
9128738	1906-PI
9128739	1953-AL
9128739	1953-PI
9128740	1952-AL
9128740	1952-PI
9157004	1100-A
9158003	1101-A
9158003	1101-AI
9158004	1100-A
9180809	12253-INA
9180809 Rep	12247AL
9202478	1948-A
9240033	12386-MI
93202400	12268-AI
93310600	3502-AL
93310600	3502-PI
93374496	12296-AI
94070341007A	
(Pick Up S10 c/MWM)	12264-AI
94070341007A	
(polea sola / pulley only 80x10x36)	12159-M
9607034100	12202-AI

9607034100	
(polea sola / pulley only)	12171-M
97114552	1126-M
Pick Up S10	
con Maxion 3,0	12294-AI
Pick Up S10 con	
Maxion 2,5 - 2,8 - 3,0	1892-MD
Pick Up S10 con	
Maxion 2,5 - 2,8 - 3,0	1892-MI
Pick Up S10 con	
Maxion 2,5 - 2,8 - 3,0	1968-MD
Pick Up S10 con	
Maxion 2,5 - 2,8 - 3,0	1968-MI
MWM (polea / pulley 80x20x36 simple rodam. / single bearing)	1965-AL
MWM (polea / pulley 80x20x36 simple rodam. / single bearing)	1965-MI
MWM	
94070341007A	12264-A
Valeo 2548207	12288-PML

CHRYSLER

04573348 (polea sola / pulley only)	12180-M
04621454 (polea sola / pulley only)	12180-M

04663515 (polea sola / pulley only)	12180-M
04777394	12180-M
0478167AB	12491-A

04884320AA	12490-FLEN
30602002F	12179-AL

CITRÖEN

0818.19	1871-FLEN
0818.19	1871-MI
0820.53	1811-M
0823.07 Rep	1161-M
0823.07 Rep	1161-MI
0823.08	12465-SKF
0823.09	12465-SKF
0829.11	1813-MI
0829.11 Rep	32011-AL
0829.11 Rep	32011-CH
0829.12	1812-MI
0829.19	1811-M
0829.19	1811-M
0829.20	1869-M
0829.20	1869-MI
0829.29	1811-M
0829.29	1811-MI
0829.30	1861-MI
0829.31	12276-MI
0829.31	1943-KOY
0829.31	1943-MI

0829.31 (completo con soporte / complete with plate)	1911-Compl
0829.31 (polea sola / pulley only)	1911-P
0829.32	1943-KOY
0829.32	1943-MI
0829.33	1901-M
0829.33	1901-MI
0829.33 Rep	32011-AL
0829.33 Rep	32011-CH
0829.35	1943-KOY
0829.35	1943-MI
0829.46	12276-MI
0829.52	12243-INA
0829.54	1811-M
0829.56	1813-MI
0829.59	1118-M
0829.59	1118-PI
0829.59	12093-M
0829.59	12093-PI

0829.60	1118-M
0829.60	1118-PI
0829.60	1118-PI
0829.61	12093-M
0829.62	12093-M
0829.62	12093-PI
0829.63	12093-M
0829.69	92100-FLEN
0829.69	92100-MI
0829.77	12334-AI
0829.82	12451-INA
0829.82	12451-AI
0829.90	12376-AI
0829.91	12376-AI
0829.A0	12551-FLEN
0829.A1	12594-M
0829.A3	12522-FLEN
0829.A4	12522-FLEN
0829.C7	12451-INA
0829.C7	12451-AI
0829.C8	12551-FLEN

CITRÖEN

0830.02	1118-M
0830.02	1118-PI
0830.02	1814-M
0830.07 Rep	1161-M
0830.07 Rep	1161-MI
0830.11	1862-MI
0830.13	1900-M
0830.13	1900-MI
0830.13 (polea sola / pulley only)	32031-AL
0830.13 (polea sola / pulley only)	32031-CH
0830.15	1814-M
0830.20	1122-M
0830.20	1122-MI
0830.23	12272-INA
0830.23	12272-MD
0830.24	1170-MD
0830.25	1171-MD
0830.28	1119-MD
0830.28	1119-PI
0830.28	12094-M
0830.28	12094-PI
0830.29	1119-MD
0830.29	12094-M
0830.30	12094-M
0830.31	12094-M
0830.31	12094-PI
0830.32	1821-M
0830.32	1821-MI
0830.40	1816-M
0830.40	1816-MI
0830.42	92102-M
0830.48	12377-PI
0830.62	12594-M
0830.63	12094-M
1281.34	3316-INA
4007.E4	1095-MI
5751.18	1124-M
5751.24	3308-M
5751.24 Rep	32002-AL
5751.24 Rep	32002-CH
5751.26	1133-INA
5751.26 Rep	12464-MI
5751.29	3313-M
5751.29	3313-MI
5751.29	32013-M
5751.30	32005-M
5751.30	32005-MI

5751.30 (polea sola c/buje de 17mm / pulley only with 17mm bushing)	32004-AL
5751.30 (polea sola c/buje de 17mm / pulley only with 17mm bushing)	32004-CH
5751.30 (polea sola c/buje de 8mm / pulley only with 8mm bushing)	32006-AL
5751.30 (polea sola c/buje de 8mm / pulley only with 8mm bushing)	32006-CH
5751-31 (amortiguador / shock absorber)	12351-AMO
5751.35	12260-AI
5751.35 (polea sola / pulley only)	32054-AL
5751.36 (polea sola / pulley only)	32053-AL
5751.36 (polea sola / pulley only)	32053-PI
5751.37 (polea sola / pulley only)	32052-AL
5751.37 (polea sola / pulley only)	32052-CH
5751.38	1931-M
5751.38	1931-MI
5751-41 (amortiguador / shock absorber)	12350-AMO
5751-43 (amortiguador / shock absorber)	12351-AMO
5751.45	3304-M
5751.45	3304-MI
5751.46	3317-MI
5751.47	3305-AL
5751.52 (sin amortiguador / without shock absorber)	33025-M
5751.52 (con amortiguador / with shock absorber)	12330-INA
5751.52 (con amortiguador / with shock absorber)	12330-MI
5751.54	12372-PI
5751.55	12375-AI
5751.55 (polea sola / pulley only)	32051-AL
5751.55 (polea sola / pulley only)	32051-CH
5751.61	12446-GAT
5751.61	12446-AI

5751.62	3317-MI
5751.63	3317-MI
5751.67	3317-MI
5751.69	3317-MI
5751.73	12374-PI
5751.73 (sin bulón / without screw)	32043-AL
5751.73 (sin bulón / without screw)	32043-CH
5751.74	12373-AI
5751-79 (amortiguador / shock absorber)	12351-AMO
5751.98	12317-AL
5751-86	12447-DAY
5751.A2	12270-AI
5751.C8	12270-AI
6453.E0	1144-M
6453.S5	1125-MI
6453.R8	3314-MI
9400829629	12093-M
9400830289	12094-M
9616660580	1170-MD
9616660780	1171-MD
9617067480 Rep	1161-M
9617067480 Rep	1161-MI
9621834980 (sin amortiguador / without shock absorber)	33025-M
9621834980 (con amortiguador / with shock absorber)	12330-INA
9621834980 (con amortiguador / with shock absorber)	12330-MI
9630535380	12465-SKF
9631847480	12372-PI
9634465780	12375-AI
9636207480	12446-GAT
9636207480	12446-AI
9637024080	12374-PI
9638115380	12093-M
9638782780	12373-AI
9648704380	12551-FLEN
9648473280	12594-M
9646675880	12270-AI
9652046680	12270-AI
97522886	1811-M
97535002	1811-M
C3 1,6 (16 válvulas con resorte / 16 valves with spring)	12330-INA

CUMMINS

3934818	12150-M
---------	----------------

3934822	12271-AI
---------	-----------------

3973556	12259-AI
---------	-----------------

CÓDIGO ORIGINAL ORIGINAL CODE	CÓDIGO CODE	EM	CÓDIGO ORIGINAL ORIGINAL CODE	CÓDIGO CODE	EM	CÓDIGO ORIGINAL ORIGINAL CODE	CÓDIGO CODE	EM
----------------------------------	----------------	----	----------------------------------	----------------	----	----------------------------------	----------------	----

CÓDIGO ORIGINAL ORIGINAL CODE	CÓDIGO CODE	EM	CÓDIGO ORIGINAL ORIGINAL CODE	CÓDIGO CODE	EM	CÓDIGO ORIGINAL ORIGINAL CODE	CÓDIGO CODE	EM
----------------------------------	----------------	----	----------------------------------	----------------	----	----------------------------------	----------------	----

DAEWOO

9128738	1127-AL
9128738	1127-PI
90411782	1127-AL
90411782	1127-PI

96103222	12234-FLEN
96103222	12234-MI
5094008601	12214-MI

12810-70802	12329-MI
12810-81401	12387-MI
12810-81401	12329-MI

DAIHATSU

13505-87102	12233-NACH
13505-87203	12495-MI

13505-87206	12495-MI
13505-87701	12310-NTN

13505-87702	12232-MI
13505-97201	12302-MI

FIAT

4178014	1852-M
4178016	12500-M
4320893	1851-M
4320893	1851-MI
4320893	1855-M
4385583	1855-M
4385583	1855-MI
4386575	1872-M
4386575	1872-MI
44270690 (polea sola / pulley only)	12027-AL
44270690 (completo con base / complete with plate)	12027-Comp
4443703	12500-M
4438894	1187-AL
4438894	1187-PI
4438894	1825-M
45648452	12460-AI
4640054	1951-M
4640054	1951-MI
46403679	12155-A
46403679	12155-AI
46416489	12091-A
46416489	12091-AI
46424716	1187-AL
46424716	1187-PI
46440604	3205-PI
46441096	3215-MI
46454419	3206-P
46454419	3206-PI
46460702 (amortiguador solo / shock absorber only)	12350-AMO
46524692	12353-AI
46524820	36057-P
46537101	12002-CH
46546354	12352-AI
46546374	12352-AI
46547566	12357-PI
46554826	1951-M
46736866	12455-INA
46740729	12012-AL

46740729	12012-M
46756937	12339-AL
46817666	12155-A
46817666	12155-AI
4740846	1816-M
4740847	1821-M
4740847	1821-MI
4741535	12389-MI
500328902	1816-M
500344132	12008-AL
532025810	12008-CH
55180011	12352-AI
5619217	1822-M
59521810	1840-M
59521810	1840-MI
5972277	1822-M
5972277	1822-MI
5997325	1818-M
5997325	1818-MI
60537975	1938-MI
60610908	3201-PI
60610908	3201-PI
60621380	12354-AI
60652126	12393-PI
60652477	12354-AI
60654130	12356-PI
60654130 Rep	12038-P
60805460	1187-AL
60805460	1187-PI
60808692	1889-MI
60813590	1950-MI
60814110	12353-AI
60814110 Rep	12036-P
60814462	12354-AI
60814917	12357-PI
71099163	12002-AL
71099163	12002-CH
71740977	1822-M
7301662	12389-MI
73501924	3201-AL

73501924	3201-PI
7541718	1832-MD
7541718	1832-MI
7553564	1819-M
7553564	1819-MI
7553565	1820-M
7553565	1820-MI
7554724	3216-P
7596727	1889-M
7596727	1889-MI
7596728	1835-M
7596728	1835-MI
7596877	1835-M
7596877	1835-MI
7641011	1187-AL
7641011	1187-PI
7641011	1187-AL
7641011	1187-PI
7702173	12007-M
7702173 (polea sola / pulley only)	12008-AL
7702173 (polea sola / pulley only)	12008-CH
7726935	1823-M
7726935	1823-MI
7740252	3202-PI
7740252	3202-M
7763644	1950-MI
7766487 (amortiguador solo / shock absorber only)	12350-AMO
7766585 (amortiguador solo / shock absorber only)	12350-AMO
7772961	1113-FLEN
7772961	12388-AI
7778565	1115-A
7778565	1115-AI
7789752	3205-PI
98463114	1816-M
99432547	1816-M
99482225	12285-PML

FORD

1004549	12300-AI
1004961	12311-MI
1004961 (polea sola / pulley only)	3405-AL
1005822	1915-MI
1019323 (polea sola / pulley only)	3404-AL
1019323	12213-INA
1019323	12213-MI
1038384	12157-MI
1039422	12395-AI
1059942	12166-M
1059942	12166-MI
1061459 (polea sola / pulley only)	12161-P
1061459	12456-AI
1069144 (polea sola / pulley only)	12161-P
1069144	12456-AI
1073096 (polea sola / pulley only)	12161-P
1073096	12456-AI
1079173	12333-PI
1089679	12311-MI
1095025	12167-P
1095025	12167-P
1095025	12167-PI
1107573	12169-A
1113174	12454-AI
1113355	12297-AI
1133988	12449-LIT
1145955	12377-PI
1197596	12448-DAY
1201181 (amortiguador solo / shock absorber only)	12350-AMO
1215978	12454-AI
1479084	12454-AI
1500004	12168-M
6177882	1915-MI
6178656	12162-PI
6577227	12209-AI
6710259	12209-AI
6777882	1915-MI
6935235	12336-MI
6935236	12337-MI
6988203	1915-MI
7392480	12300-AI
8966821	42007-M
7109163 (polea sola / pulley only)	42001-AL
7109163 (polea sola / pulley only)	42001-MI
7109163 (polea sola / pulley only)	42001-CH
1L5Q-6A228-AB (polea sola / pulley only)	12158-M

2S6Q-6B217AA	12522-AI
2T1Q-6K254AA	12454-AI
2T1Q-6K254AB	12454-AI
3M5Q-6B217AA	12522-AI
75HM-6K254AA	1839-MD
75HM-6K254AA	1839-MI
84FF-6K254AA	1842-MI
84SM-6K254CA	1837-FLEN
84SM-6K254CA	1837-MI
93BB-19A216BF	12336-MI
93BB-19A216BF	12314-MI
93BB-19A216CE	12337-MI
93BB-6A228AE	12456-AI
93FF-6K254AB	1915-MI
94FF-19A216AB	12212-INA
94FF-19A216AB (polea sola / pulley only)	42013-AL
94FF-19A216AB (polea sola / pulley only)	42013-CH
94FF-19A216AC	12213-INA
94FF-19A216AC	12213-MI
96BF-6A228AB	12300-AI
96FF-6K254AA	1985-M
96FF-6K254AA	1985-MI
96FF-6K254AB	1915-MI
96FF-6K254CB	1099-A
96FF-6K254CB	1099-AI
96FF-6K254DA	1902-M
96FF-6K254DA	1902-MI
96FF-6K254DC	1123-M
96FF-6K254DC	1123-MI
97BB-6A228AE (polea sola / pulley only)	12161-P
97BB-6A228AE	12456-AI
97BB-6A228AG (polea sola / pulley only)	12161-P
97BB-6A228AG	12456-AI
97FF-6K254DC	1123-M
97FF-6K254DC	1123-MI
97FF-3K738BH	12449-LIT
98MM-6K254AC	12092-A
98MM-6K254AC	12297-AI
98MM-6K254AD	12297-AI
928F-6A228	42005-AL
F87A-6A228AA	42007-M
928F-6A228AB	12209-AI
928M-6K250BC	1904-M
928M-6K250BC	1904-MI
928M-6K250DC	1096-M
928M-6K250DC	1096-PI
928M-6K254AC	1903-PI
928M-6M250DC	1096-M
928M-6M250DC	1096-PI
978M-6M250-AA	12157-MI
988M-M6K254AC	12169-A
BF5T10B300A	12294-AI

F57A-6B209BA	12250-LIT
XS4Q6B217AD	12333-PI
XS6E-19A216BB	12295-MI
YS4Q-6K254AB	12454-SNR
YS4Q-6K254AB	12454-MI
94070341007A	
Pick Up Ranger c/ MWM	12264-A
94070341007A (polea sola / pulley only 80x10x36)	12159-M
Ecosport 1.4 TDCI (aire acondicionado y dirección hidráulica / air conditioning and hydraulic direction)	12316-PI
F100 (polea lisa / smooth pulley 80x25x10)	42008-AL
F100 (polea lisa / smooth pulley 90x29x17)	42014-AL
F100 y Ranger Diesel (polea acanalada / grooved pulley)	E1463-P
F100 y Ranger Diesel (polea acanalada / grooved pulley)	E1463-M
Pick Up Ranger con Maxion 3,0	12294-AI
Pick Up Ranger con Maxion 2,5 - 2,8 - 3,0	1892-MD
Pick Up Ranger con Maxion 2,5 - 2,8 - 3,0	1892-MI
Pick Up Ranger con Maxion 2,5 - 2,8 - 3,0	1968-MD
Pick Up Ranger con Maxion 2,5 - 2,8 - 3,0	1968-MI
MWM (polea / pulley 80x20x36 simple rodam. / single bearing)	12160-M
MWM (polea / pulley 80x20x36 simple rodam. / single bearing)	1965-AL
MWM (polea / pulley 80x20x36 simple rodam. / single bearing)	1965-MI
MWM (polea tensora en V para alternador / V pulley for alternator)	12165-M

A NO ORIGINAL

OE NUMBER

CÓDIGO ORIGINAL ORIGINAL CODE	CÓDIGO CODE EM	CÓDIGO ORIGINAL ORIGINAL CODE	CÓDIGO CODE EM	CÓDIGO ORIGINAL ORIGINAL CODE	CÓDIGO CODE EM
-------------------------------	----------------	-------------------------------	----------------	-------------------------------	----------------

CÓDIGO ORIGINAL ORIGINAL CODE	CÓDIGO CODE EM	CÓDIGO ORIGINAL ORIGINAL CODE	CÓDIGO CODE EM	CÓDIGO ORIGINAL ORIGINAL CODE	CÓDIGO CODE EM
-------------------------------	----------------	-------------------------------	----------------	-------------------------------	----------------

HONDA

13404-PT0-003	1178-KOY	14510-PE0-003/004	12511-MI	14510-PR3-004	12510-MI
14510-P2A-004	12509-MI	14510-PE0-005	12511-MI	14510-PM7-004	1927-MI
14510-P30-003	12510-MI	14510-PH3-003	12219-MI	14510-P08-003	12509-MI
14510-P8-003	12509-MI	14510-PH3-004	12219-MI	14510-PT0-003	1905-MI
14510-PD2-003	12218-MI	14510-PK1-003	12219-MI	14510-PY3-003/004	12211-NTN
14510-PC0-003	12218-MI	14510-PR3-003	12510-MI		

MAXION

70670208	E1621-M	ETC8560	12164-MI	LHV100150	1892-MI
ERR 4708	12151-M	ETC8560A	1892-MD	LHV100680	1968-MD
ERR1792A	1968-MD	ETC8560A	1892-MI	LHV100680	1968-MI
ERR1792A	1968-MI	LHP 100680	12163-M	Pick Up Ranger y	
ETC8560	12164-M	LHV100150	1892-MD	S10 con Maxion 3,0	12294-AI

HYUNDAI

23317-42000	1061-MI	23357-33120	1184-M	24410-22000	12224-MI
23317-42000	1061-M	23357-42000	1184-MI	24410-22020	12195-M
23317-42010	1061-MI	23357-42000	1184-M	24410-23011	12305-NSK
23317-42010	1061-M	23357-42010	1184-MI	24410-32000	12194-FLEN
23317-42020	1061-MI	23357-42010	1184-M	24450-33010	12194-MI
23317-42020	12401-MI	23357-42020	1184-MI	24450-33010	12404-MI
23357-32000	12401-MI	23357-42020	12277-NSK	24450-38010	12307-NACH
23357-32010	12206-FLEN	24410-02510	12400-MI	Elantra polea Multi V /	
23357-33120	12206-MI	24410-21010	12224-MI	pulley (77x19x17)	

MAZDA

B660-12700D	12222-FLEN	F805-12700A	12220-MI	FE3N-12-730	1075-FLEN
B660-12700D	12222-MI	F805-12700C	12220-NACH	FP05-12700A	12325-NSK
B660-12700E	12222-FLEN	F805-12700C	12220-MI	PN11-12700	12196-KOY
B660-12700E	12222-MI	FE1H-12700A	12223-FLEN	R201-12700A	12221-FLEN
B660-12730	12235-FLEN	FE1H-12700A	12223-MI	RF03-12700A	12527-MI
B660-12730	12235-MI	F805-12700C	12220-MI	RF14-12730	12524-MI
B660-12730C	12235-FLEN	FE1H-12700A	12223-FLEN	RF71-12730A	12524-MI
B660-12730C	12235-MI	FE1H-12700A	12223-MI	RF71-12770C	12525-MI
F801-12700	12526-MI	FE1H-12730	12197-MI	RPC61-12700	12525-MI
F805-12700A	12220-NACH				

ISUZU

5-12539-0132	1048-M	8-94382-2140	1049-FLEN	8-94472349-1	12282-NSK
8-94215197-1	12255-MI	8-94382-2150	1050-MI		

MERCEDES BENZ

IVECO

4740846	12389-MI	7301662	12389-MI	500332622	12408-AI
---------	----------	---------	----------	-----------	----------

000 202 00 19	12605-M	112 200 03 70	14020-FLEN	601 200 09 70	12181-P
102 200 33 70	12649-AI	112 200 03 70	FS-27915	604 150 00 60	12290-PML
102 200 69 70	12649-AI	112 200 06 70	14020-FLEN	611 150 01 60	12289-PML
103 200 05 70	14015-FLEN	112 200 06 70	FS-27915	611 200 02 70	12604-AI
103 200 05 70	FS-99093	112 200 08 70	14020-FLEN	611 200 03 70	12604-AI
103 200 08 70	14023-FLEN	112 200 08 70	FS-27915	611 200 05 70	12604-AI
103 200 08 70	FA-99201	112 200 09 70	14020-FLEN	611 200 02 70	12604-AI
104 200 08 70	FS-27099	112 200 09 70	FS-27915	668 202 0519	32058-M
111 200 00 70	14017-FLEN	119 200 02 70	14019-FLEN	906 200 14 70	12600-AI
111 200 00 70	FS-27916	119 200 02 70	FA-99207	906 200 17 70	12600-AI
111 200 01 19	FS-99093	119 200 04 70	14016-P	906 200 20 70	12600-AI
111 200 06 70	14021-FLEN	119 200 04 70	FS-99172	Polea sola para motor /	
111 200 06 70	FS-27911	119 200 10 70	14018-FLEN	Pulley only for engine	
111 200 07 70	14021-FLEN	119 200 10 70	FA-99326	OM904 y OM906	12342-M
111 200 07 70	FS-27911	119 200 11 70	14018-FLEN	Maxion 2,5 - 2,8	
111 200 12 70	14021-FLEN	166 155 02 15	FA-99326	(Sprinter)	1892-MD
111 200 12 70	FS-27911	166 202 0019	12291-PML	Maxion 2,5 - 2,8	
111 990 03 05	14021-FLEN	166 202 0019	32058-M	(Sprinter)	1892-MI
111 990 03 05	FS-27911	166 202 0419	32058-M	Maxion 2,5 - 2,8	
112 200 00 70	14020-FLEN	166 202 0819	32058-M	(Sprinter)	1968-MD
112 200 00 70	FS-27915	226 202 0019	32058-M	Maxion 2,5 - 2,8	
112 200 01 70	14020-FLEN	266 202 0019	32058-M	(Sprinter)	1968-MI
112 200 01 70	FS-27915	601 200 07 70	12182-P		

JEEP

53010158	12178-AL	Cherokee polea sola /			
		pulley only 69,5x17x31	E1485-M		

KIA

B630-12700C	12410-MI	B660-12730	12235-MI	OK933-12730	12325-MI
B660-12700D	12222-FLEN	B660-12730C	12235-FLEN	OK937-12730	12325-MI
B660-12700D	12222-MI	B660-12730C	12235-MI	OK938-12730	12325-MI
B660-12700E	12222-FLEN	OK927-12700	12223-FLEN	OK972-12-730	1075-FLEN
B660-12700E	12222-MI	OK927-12700	12223-MI	R201-12700A	12221-FLEN
B660-12730	12235-FLEN				

LADA

2105-1006124	12190-M	2108-1006120	12191-M		
--------------	---------	--------------	---------	--	--

LAND ROVER

ERR 6439	12603-AI				
----------	----------	--	--	--	--

LITTENS

933538 48	1102-A	940703 4100	12202-A	964967 5880	12270-A
933538 48	12275-A	940703 4100A	12264-A		

A No ORIGINAL

OE NUMBER

CÓDIGO ORIGINAL ORIGINAL CODE

CÓDIGO ORIGINAL ORIGINAL CODE

CÓDIGO ORIGINAL ORIGINAL CODE

CÓDIGO ORIGINAL ORIGINAL CODE

CÓDIGO ORIGINAL ORIGINAL CODE

CÓDIGO ORIGINAL ORIGINAL CODE

MITSUBISHI

MD008965	I2279-MI
MD009560	I2415-MI
MD011536	I2305-NSK
MD008965	I2279-MI
MD009560	I2415-MI
MD011536	I2305-NSK
MD012587	I2309-KOY
MD040754	I2401-MI
MD050125	I184-M
MD050125	I184-MI
MD050135	I061-M
MD050135	I061-MI
MD064641	I2530-MI

MD104578	I2227-NSK
MD109958	I2280-MI
MD115976	I2206-FLEN
MD115976	I2206-MI
MD128765	I2531-MI
MD129033	I2416-MI
MD129355	I2194-FLEN
MD129355	I2194-MI
MD140071	I2324-NACH
MD140071	I2341-MI
MD140186	I2413-MI
MD151447	I2306-MI
MD154352	I2328-NSK

MD156604	I055-MI
MD169592	I2226-KOY
MD185544	I2528-MI
MD192068	I2528-MI
MD320174	I2323-NSK
MD329976	I2322-NSK
MD352473	I2528-MI
Lancer pœlea en V / Multi V	
pulley (77x19x17)	I2307-NACH
Pœlea en VIV pulley)	
(76x17x19,5)	I2189-M
Pœlea en VIV pulley)	
(91x17x19,5)	I2188-M

MWM

94070341007A (pœlea sola doble rodamiento / pulley only with double bearing)	I2159-MI
94070341007A (pœlea sola doble rodamiento / pulley only with double bearing)	I2159-M

94070341007A (pœlea sola doble rodamiento / pulley only with double bearing)	I965-AL
94070341007A (pœlea sola doble rodamiento / pulley only with double bearing)	I965-MI

94070341007A Pick Up Ranger y S10	I2264-A
-----------------------------------	----------------

NISSAN

I3070-01M00	I2215-FLEN
I3070-01M00	I2215-KOY
I3070-05E00	I2535-MI
I3070-05E10	I2535-MI
I3070-16A02	I2327-NACH
I3070-16A03	I2327-NACH
I3070-16A10	I2540-MI
I3070-D0100	I2326-NSK
I3070-V5001	I2217-FLEN
I3070-V5001	I2217-MI
I3070-V7201	I2312-MI

I3074-16A00	I2542-PI
I3077-54A00	I2308-NSK
I3077-54A01	I2308-NSK
I3077-D4200	I2541-MI
I3077-F6510	I2539-MI
I3077-F6511	I2553-MI
I3077-F6512	I2552-MI
I3077-V7200	I2313-MI
Maxion 3,0	
(pick up Frontier)	I892-MD

Maxion 3,0	
(pick up Frontier)	I892-MI
Maxion 3,0	
(pick up Frontier)	I968-MD
Maxion 3,0	
(pick up Frontier)	I968-MI
Maxion 3,0	
(pick up Frontier alternador)	I2294-AI

PEUGEOT

0818.19	I871-FLEN
0818.19	I871-MI
0818.20	I944-M
0820.53	I811-M
0823.07 Rep	I161-M
0823.07 Rep	I161-MI
0823.08	I2465-SKF
0823.09	I2465-SKF
0829.10	I817-M
0829.10	I817-MI
0829.11	I813-MI
0829.11 (pœlea sola / pulley only)	32011-AL
0829.11 (pœlea sola / pulley only)	32011-CH
0829.12	I812-MI
0829.19	I811-M
0829.19	I811-MI

0829.20	I869-M
0829.20	I869-MI
0829.22	I2156-M
0829.29	I811-M
0829.29	I811-MI
0829.30	I861-MI
0829.31	I2276-MI
0829.32	I943-KOY
0829.32	I943-MI
0829.33	I901-M
0829.33 (pœlea sola / pulley only)	32011-AL
0829.33 (pœlea sola / pulley only)	32011-CH
0829.35	I943-KOY
0829.35	I943-MI
0829.46	I2276-MI
0829.47	I901-M

0829.47	I901-MI
0829.49	I121-M
0829.52	I2243-INA
0829.54	I811-M
0829.56	I813-MI
0829.59	I118-M
0829.59	I118-PI
0829.59	I2093-M
0829.59	I2093-PI
0829.60	I118-M
0829.60	I118-PI
0829.62	I2093-M
0829.62	I2093-PI
0829.69	92100-FLEN
0829.69	92100-MI
0829.77	I2334-AI
0829.82	I2451-INA
0829.82	I2451-AI

PEUGEOT

0829.90	I2376-AI
0829.91	I2376-AI
0829.A0	I2551-FLEN
0829.A1	I2594-M
0829.A3	I2522-FLEN
0829.A4	I2522-FLEN
0829.C7	I2451-INA
0829.C7	I2451-AI
0829.C8	I2551-FLEN
0830.02	I118-M
0830.02	I118-PI
0830.02	I814-M
0830.07 Rep	I161-M
0830.07 Rep	I161-MI
0830.11	I862-MI
0830.12	I945-M
0830.13	I900-M
0830.13	I900-MI
0830.13 Rep	32031-AL
0830.13 Rep	32031-CH
0830.15	I814-M
0830.20	I122-M
0830.20	I122-MI
0830.23	I2272-INA
0830.23	I2272-MD
0830.24	I170-MD
0830.25	I171-MD
0830.28	I119-MD
0830.28	I119-PI
0830.28	I2094-M
0830.28	I2094-PI
0830.29	I119-MD
0830.29	I119-PI
0830.30	I2094-M
0830.31	I2094-M
0830.31	I2094-PI
0830.32	I821-M
0830.32	I821-MI
0830.37	I907-AL
0830.37	I907-MI
0830.40	I816-M
0830.40	I816-MI
0830.48	I2377-PI
0830.62	I2594-M
0830.63	I2094-M
I281.13	E1499-M
I281.34	3316-INA
I281.38	32017-AL
I281.38	32017-P
4007.E4	I095-MI
4453.S5 (pœlea sola / pulley only)	I2095-AL
4453.S5 (pœlea sola / pulley only)	I2095-M
5751.04	E1500-M
5751.08	3306-AL

5751.08	3306-CH
5751.11	3306-AL
5751.11	3306-CH
5751.14	3306-AL
5751.14	3306-CH
5751.15	3302-M
5751.15	3302-MI
5751.18	I124-M
5751.20	32009-AL
5751.20	32009-MI
5751.23	E1492-M
5751.24	3308-M
5751.24 (pœlea sola / pulley only)	32002-AL
5751.24 (pœlea sola / pulley only)	32002-CH
5751.26	I133-INA
5751.26 Rep	I2464-MI
5751.29	3313-M
5751.29	3313-MI
5751.29	33013-M
5751.30	32005-M
5751.30	32005-MI
5751.30 (pœlea sola c/buje de 8 mm / pulley only with 8 mm bushing)	
	32006-AL
5751.30 (pœlea sola c/buje de 8 mm / pulley only with 8 mm bushing)	
	32006-CH
5751.30 (pœlea sola c/buje de 17 mm / pulley only with 17 mm bushing)	
	32004-AL
5751.30 (pœlea sola c/buje de 17 mm / pulley only with 17 mm bushing)	
	32004-CH
5751.30 (pœlea sola / pulley only)	
	32007-AL
5751-31 (amortiguador / shock absorber)	
	I2351-AMO
5751.34 (pœlea sola / pulley only)	
	32055-AL
5751.34 (pœlea sola / pulley only)	
	32055-CH
5751.35	
	I2260-AI
5751.35 (pœlea sola / pulley only)	
	32054-AL
5751.36 (pœlea sola / pulley only)	
	32053-AL
5751.36 (pœlea sola / pulley only)	
	32053-PI
5751.37 (pœlea sola / pulley only)	
	32052-AL
5751.37 (pœlea sola / pulley only)	
	32052-CH
5751.38	I931-M
5751.38	I931-MI

5751-41 (amortiguador / shock absorber)	
	I2350-AMO
5751-43 (amortiguador / shock absorber)	
	I2351-AMO
5751.45	3304-M
5751.45	3304-MI
5751.46	3317-MI
5751.47	3305-AL
5751.50	32014-Comp
5751.50 (pœlea sola / pulley only)	
	32014-CH
5751.51 (pœlea sola / pulley only)	
	32035-AL
5751.51 (pœlea sola / pulley only)	
	32035-CH
5751.52 sin amortiguador / without shock absorber	
	33025-M
5751.52 con amortiguador / with shock absorber	
	I2330-INA
5751.52 con amortiguador / with shock absorber	
	I2330-MI
5751.52 (pœlea sola / pulley only)	
	32026-AL
5751.54	I2372-PI
5751.55	I2375-AI
5751.55 (pœlea sola / pulley only)	
	32051-AL
5751.55 (pœlea sola / pulley only)	
	32051-CH
5751.60	3320-PI
5751.74	I2373-AI
5751.60 (pœlea sola / pulley only)	
	32047-AL
5751.61	I2446-GAT
5751.61	I2446-AI
5751.62	3317-MI
5751.63	3317-MI
5751.67	3317-MI
5751.69	3317-MI
5751.73	I2374-PI
5751.73 (pœlea sola sin bulón / pulley only without screw)	
	32043-AL
5751.73 (pœlea sola sin bulón / pulley only without screw)	
	32043-CH
5751-79 (amortiguador / shock absorber)	
	I2351-AMO
5751.98	I2317-AL
5751-31	I2351-AMO
5751-43	I2351-AMO
5751-61	I2446-GAT
5751-61	I2446-AI
5751-79	I2351-AMO
5751-86	I2447-DAY
5751.97	I2270-LIT
5751.A2	I2270-AI
5751.C8	I2270-AI

CÓDIGO ORIGINAL ORIGINAL CODE

CÓDIGO ORIGINAL ORIGINAL CODE

CÓDIGO ORIGINAL ORIGINAL CODE

CÓDIGO ORIGINAL ORIGINAL CODE

CÓDIGO ORIGINAL ORIGINAL CODE

CÓDIGO ORIGINAL ORIGINAL CODE

PEUGEOT

5753.54	E1496-M
6353.S5	1125-MI
6453.73	1849-M
6453.73 (polea sola / pulley only)	32015-P
6453.76	1849-M
6453.76 (polea sola / pulley only)	32015-P
6453.EO	1144-M
6453.G4	3311-MI
6453.G4 (polea sola / pulley only)	32026-AL
6453.R8	3314-MI
6453.S5 (polea sola / pulley only)	32026-AL
6453.Y1	12244-INA
6453.Y1 Rep	12464-MI

9400829629	12093-M
9400829969	12334-AI
9400830289	12094-M
96112753	3306-CH
96146660	3306-CH
9616660580	1170-MD
9616660780	1171-MD
9617067480 Rep	1161-M
9617067480 Rep	1161-MI
9621626080	32035-MI
9621626080	32035-CH
9621834980 sin amortiguador / without shock absorber	33025-M
9621834980 con amortiguador / with shock absorber	12330-INA
9621834980 con amortiguador / with shock absorber	12330-MI

9630535380	12465-SKF
9631847480	12372-PI
9634465780	12375-AI
9636207480	12446-GAT
9636207480	12446-AI
9637024080	12374-PI
9638115380	12093-M
9638782780	12373-AI
9648704380	12551-FLEN
9648473280	12594-M
9649675880	12270-LIT
9652046680	12270-AI
97522886	1811-M
97535002	1811-M
Valeo 2547917	12292-PML

RENAULT

5001001259	1816-M
5001001259	1816-MI
5001001272	1821-M
5001001272	1821-MI
5010284907	12408-AI
5010553544	12408-AI
7431275380 (polea sola / pulley only)	22014-AL
7431275380 (polea sola / pulley only)	22014-MI
7438146139	22015-P
7439135036	1930-FLEN
7439135036 (polea sola / pulley only)	1930-Rep
7439146139	1143-P
7439146376	12200-NSK
7439440329	1137-FLEN
7439440329	1137-MI
7700100671	1148-M
7700100671	1148-MI
7700102395 (polea sola / pulley only)	22026-AL
7700102395 (polea sola / pulley only)	22026-CH
7700102395 (amortiguador solo / shock absorber only)	12351-AMO
7700102872	12445-AI
7700102872 (polea sola / pulley only)	22025-AL
7700102872 (polea sola / pulley only)	22025-CH
7700102931	22026-CH
7700104092	22026-CH
7700104676	12607-M
7700105325	12245-MI
7700106054	12425-MI
7700106708 Rep	22018-AL

7700106708 rep	22018-CH
7700106708	12331-INA
7700106708 (amortiguador solo / shock absorber only)	12351-AMO
7700107150	12208-P
7700107150	12208-PI
7700107249	1153-M
7700108117	12177-A
7700108117	12177-AI
7700108626	12424-PI
7700114860	12261-AI
7700115862	12201-A
7700115862	12201-AI
7700247217	20013-M
7700247218	12175-CH
7700271618	1141-M
7700271618	1141-MD
7700271618	1141-MDI
7700272652	1135-SKF
7700272652	1135-MI
7700272972	1150-M
7700272972	1150-MI
7700273277	1145-M
7700273277	1145-MI
7700276640	1149-M
7700726640	1149-MI
7700692315	1817-M
7700692315	1817-MI
7700721690	1857-AL
7700721690	1857-MI
7700722452	1858-M
7700722452	1858-MI
7700726440	1173-M
7700726440	1173-MI
7700733489	1881-M
7700733489	1881-MI
7700735486	1854-MD

7700735486	1854-MI
7700736085	1863-M
7700736085	1863-MI
7700736419	1865-M
7700736419	1880-M
7700736419	1880-MI
7700745215	1882-M
7700745215 (polea sola / pulley only)	22011-AL
7700745215 (polea sola / pulley only)	22011-M
7700836112	12606-MD
7700850115	12262-SKF
7700850603	3613-P
7700850603	3613-AL
7700851321	1139-M
7700851321	1139-PI
7700852114 (polea sola / pulley only)	22010-AL
7700852114 (polea sola / pulley only)	22010-CH
7700852410	1142-M
7700852410 (polea sola / pulley only)	22006-M
7700853550	12173-M
7700857492	12429-MI
7700858358	1134-MI
7700860455E	12273-INA
7700860455E	12273-MI
7700860603	1138-AL
7700860603	1138-CH
7700860844	1136-MI
7700860883	22020-KOY
7700860883	12338-MI
7700861810	1152-AI
7700861810 (amortiguador solo / shock absorber only)	12351-AMO

RENAULT

7700862615	1965-AL
7700862615	1965-MI
7700862743	12176-M
7700862744	3622-M
7700863111	1881-M
7700863111	1881-MI
7700864573	12274-M
7700864573	12274-INA
7700868201	3623-PI
7700867985	1151-M
7700869666	22031-M
7700869666	22031-PI
7700869684	12175-P
7700869684	12175-M
7700869684	22038-AL
7700870432	36056-M
7700870937	1151-M
7700871169	1913-M
7700871169	1913-MI
7700872108	1149-M
7700872108	1149-MI

7700872531	1112-AI
7700872531	1112-FLEN
7700873731	1112-AI
7700873731	1112-FLEN
7700875305	1146-M
7700875307	1147-M
7702089333	12174-AL
7702217979	22008-AL
7702217979	22008-M
7702217980	22007-AL
7702217980	22007-M
7702229390	12263-LIT
7701055871	12301-PML
8200004593	FU-15492
8200007980	FS-05492
8200009194	FS-05492
8200009194B	FS-05492
8200040161	22031-M
8200040161	22031-PI
8200064664	12246-PI
8200065479	1151-M

8200065970	12320-A
8200065970	12320-AI
8200071404	12428-PI
8200079341	12201-A
8200079341	12201-AI
8200102612	1145-M
8200102941	12298-A
8200102941	12298-AI
8200103069	12299-AI
8200127487	FS-05492
8200130598	12320-A
8200130598	12320-AI
8200191342	12593-AI
8200230958	12320-A
8200277606	12445-AI
8200347761	12593-AI
8200403954	12445-AI
8200603359	12445-AI
9135036	12200-NSK
9617067480	1161-MI

ROVER

ADU 8533	1897-FLEN
AHU 2625	12192-P
CAM 9153	1896-NACH
CDU 2049	12431-PI

CDU 3359	1895-FLEN
CDU 3558	1894-NTN
CDU 3558	1894-MI
FDU1055	1927-MI

LHP100390	12432-MI
LHP100480	1178-KOY
LHP100840	12433-MI
LHP10450	1905-MI

SCANIA

1371788	12463-AI
---------	-----------------

1493670	12463-AI
---------	-----------------

SEAT

028 109 244	1128-FLEN
028 109 244	1128-MI
028 109243AF	1104-A
028 109243AF	1104-AI
038 109243F	1107-A
038 109243G	1107-A
038 109243M	12458-AI
038 109243N	1107-A

038 109244B	1166-M
038 109244B	1166-RT
038 109244E	1167-RT
038 109244E	1167-MI
051 109 243A	1129-FLEN
058 109 243B	1130-MI
058 109 244	1131-FLEN

058 109 244	1131-MI
06A 109479	1157-FLEN
06A 109479	1157-AI
06A 109479A	1157-FLEN
06A 109479A	1157-AI
06A 109479C	1157-FLEN
06A 109479C	1157-AI

SSANGYONG

102 200 69 70	12694-AI
---------------	-----------------

SUBARU

13069-AA036	12225-MI
13070-KA020	12304-NTN

13073-AA142	12236-FLEN
-------------	-------------------

13085-AA010	12237-FLEN
-------------	-------------------

CÓDIGO ORIGINAL ORIGINAL CODE

CÓDIGO ORIGINAL ORIGINAL CODE

CÓDIGO ORIGINAL ORIGINAL CODE

CÓDIGO ORIGINAL ORIGINAL CODE

CÓDIGO ORIGINAL ORIGINAL CODE

CÓDIGO ORIGINAL ORIGINAL CODE

12810-53B01	12230-NTN
12810-70802	12329-MI
12810-71C02	12229-KOY
12810-71C02	12229-MI

12810-81401	12329-MI
12810-82003	12210-FLEN
12810-84001	12281-FLEN

12810-86501	12231-NTN
90412884	12265-DAY
90412884	12265-AI

059 109 244B	12575-FLEN
059 109 244D	12575-FLEN
059 109 243D	12570-FLEN
059 109 243J	12570-FLEN
059 109 479B	FD-99003
059 109 487A	FA-99002
059 109 487B	FA-99002
059 109 487C	FA-99002
059 903 341A	12605-M
068 109 243	1806-M
068 109 243C	1806-M
068 109 243F	1806-M
068 109 243F	1806-MI
069 109 243	52004-P
06A 109 479	1157-AI
06A 109 479A	1157-AI
06A 109 479B	1157-AI
06A 109 479C	1157-AI
06A 903 315D	12258-AI
06A 903 315E	12258-AI
06B 109 243A	12240-NTN
06B 109 243A	12240-FLEN
06B 109 2043B	12573-FLEN
06B 109 243D	12240-FLEN
06B 109 243F	12240-FLEN

06B 109 244	12478-M
06B 109 244C	12595-AI
06B 109 244D	12595-AI
06B 109 244E	12595-AI
06B 109 477	12242-AI
06B 109 477A	FD-99199
06B 109 479	12242-AI
06C 109 244	12482-FLEN
06C 109 244C	12481-FLEN
06D 109 243	12701-AI
06D 109 243B	12573-AI
06D 109 244A	12700-M
06D 109 244B	12700-M
6K0 145 299	FA-20912
074 109 243E	12580-FLEN
074 109 243G	12241-MI
074 109 243M	12580-FLEN
074 130 195	12578-FLEN
074 130 195B	12578-FLEN
074 130 245	12319-PI
074 145 278E	FU-20996
077 109 244C	12576-FLEN
077 109 244E	12577-FLEN
077 109 479D	FD99022

077 109 485E	FS99012
078 109 243Q	12480-MI
078 109 243R	12480-MI
078 109 243S	12480-MI
078 109 244H	12479-FLEN
078 109 244J	12479-FLEN
078 109 479E	FD-99001
078 109 487A	FA-99014
078 903 133AB	12257-AI
078 9031 33AB	
(polea sola / pulley only)	22014-MI
078 903 133B	12257-AI
078 903 133T	12257-AI
250 145 299B	12271-AI
2TO 145 299B	12259-A
377 145 299	12248-AI
377 145 299 (polea acanalada sola / grooved pulley only)	12462-PI
377 260 299	12249-AI
377 260 299 (polea lisa sola / smooth pulley only)	12170-M
Bosch F010LD1120	12293-PML

13503-10011	12340-NSK
13503-10021	12340-NSK
13503-54020	1989-MI
13503-54030	1014-MI
13503-54030	1014-PI
13503-63011	12187-MI
13505-15041	12216-FLEN
13505-15041	12216-NACH
13505-15050	12254-FLEN
13505-15050	12254-MI

13505-54010	1988-MI
13505-54020	1988-MI
13505-54021	1013-MI
13505-63010	12186-MI
13505-63021	12186-MI
13505-64021	12184-MI
13505-67040	1176-MI
13505-74011	12183-MI
15503-64020	12205-FLEN
15503-64020	12205-MI

Hilux (polea tensora en V para alternador / V pulley for alternator) **1015-M**

Hilux (polea tensora en V para alternador / V pulley for alternator) **12185-M**

Hilux (polea tensora plana para aire acondicionado / flat pulley for air conditioning) **12186-M**

026 109 243	1805-M
026 109 243A	1805-M
026 109 243C	1805-M
026 109 243E	1805-M
026 109 243E	1805-MI
026 109 243L	1805-M
028 109 243AF	1104-A
028 109 243AF	1104-AI
028 109 243F	1104-AI
028 109 244	1128-FLEN
028 109 244	1128-M
028 109 244	1128-MI
028 145 278E	3104-P
028 145 278E	3104-PI
028 145 299.1	E1595-M
028 260 299 (polea lisa sola / smooth pulley only)	12170-M
028 260 299-2 (amortiguador solo / shock absorber only)	12461-AMO
028 260 299-2	12443-AI
028 903 119A	12252-INA
028 903 119A	12252-PML
028 903 119AA	12251-INA
028 903 119AA	12251-PML
028 903 119AC	12286-PML
028 903 315AE	FA-99049
028 903 315F	FA-99049
028 903 315M	12452-AI
028 903 315N	FA-99048
028 903 315R	FA-99048
030 109 243D	12283-AI
030 109 243F	12283-AI
030 109 243J	12283-AI
030 109 243K	12283-AI
030 145 299C	12450-AI
030 145 299E	12450-AI
030 145 299F	12450-AI

030 145 299H	12601-AI
031 145 276	1174-AI
032 145 299A	12602-AI
032 145 299C	FA-20912
036 109 181A	12440-MI
036 109 243AB	12549-AI
036 109 243AD	12549-AI
036 109 243E	12549-AI
036 109 243L	12549-AI
036 109 243R	12549-AI
036 109 244D	12438-PI
037 145 276	FU-20996
037 145 276A	FU-20996
037 903 315A	FA-99010
037 903 315B	FA-99010
037 903 315C	FA-99010
038 109 243	1107-A
038 109 243E	1808-M
038 109 243D	1107-A
038 109 243F	1107-A
038 109 243G	1107-A
038 109 243H	1107-A
038 109 243M	12458-AI
038 109 243N	1107-A
038 109 244B	1166-M
038 109 244E	1167-RT
038 109 244E	1167-M
038 109 244E	1167-MI
038 109 244J	12474-M
038 109 244N	12474-M
038 145 276	1174-PI
038 145 278	12453-PI
038 145 299R5	E1593-AL
038 145 299R5	
(polea sola / pulley only)	52002-P
038 145 299R5	
(polea sola / pulley only)	52002-AL

038 903 119M	12286-PML
038 903 315A	FA-20907
038 903 315C	12361-AI
038 903 315D	12459-AI
038 903 315E	FA-20907
038 903 315K	FA-20907
038 903 315P	12459-AI
03G 109 243	12598-FLEN
03G 109 243A	12597-M
03G 109 244	12596-M
03L 109 243A	12599-M
03L 109 243E	12599-M
045 109 243B	12484-FLEN
045 109 243C	12239-AI
045 109 243F	12458-AI
045 109 244A	12238-FLEN
045 109 244A	12238-M
045 109 479B	FD-99004
045 109 479C	FD-99005
051 109 243A	1129-FLEN
058 109 243B	1130-MI
058 109 243C	12228-FLEN
058 109 243E	12228-FLEN
058 109 244	1131-FLEN
058 109 244	1131-M
058 109 244	1131-MI
058 260 511	12362-MI
058 260 511 (polea acanalada / grooved pulley)	12203-P
058 109 479B	FD-99020
058 903 133	12256-AI
058 903 133B	12256-AI
058 903 133C	12256-AI
058 903 133D	12256-AI
058 903 341A	12605-M
059 109 244	12575-FLEN
059 109 244A	12575-FLEN

1357934	12585-FLEN
1357936-2	12585-FLEN
3321435	12581-FLEN
3342134	12582-FLEN
3342143	12581-FLEN
3532179	12583-FLEN
3547708	12584-FLEN
3547715	12584-FLEN
445545	12582-FLEN
463633-8	12587-FLEN
6842125	12199-M
6842592	12207-FLEN

9135036	12200-NSK
9135555	12198-M
9135556	12198-M
9135937-2	12589-FLEN
9135946	12589-FLEN

VOLVO

IMPORTANTE: Todos los códigos de EM EUROMOTOR que comienzan con FA, FD, FS o FU corresponden a tensores FLENNOR. Los precios de los mismos se deben buscar en la **Lista de Tensores FLENNOR**.

IMPORTANT: All the EM EUROMOTOR codes that begin with FA, FD, FS or FU are FLENNOR tensioners. The price of these tensioners must be searched in the **FLENNOR price list**.

A N° ORIGINAL

OE NUMBER

CÓDIGO SKF **CÓDIGO EM** **CÓDIGO SKF** **CÓDIGO EM** **CÓDIGO SKF** **CÓDIGO EM**

CÓDIGO SKF **CÓDIGO EM** **CÓDIGO SKF** **CÓDIGO EM** **CÓDIGO SKF** **CÓDIGO EM**

VKM01004	12294-AI
VKM02000	12353-AI
VKM02022	12357-PI
VKM02023	3205-PI
VKM02026 Rep	12008-CH
VKM02024	12352-AI
VKM03001	12260-AI
VKM03011	32009-MI
VKM03028	12375-AI
VKM03030	12373-AI
VKM04001	12454-AI
VKM05020	12265-AI
VKM11000	1805-M
VKM11000	1805-MI
VKM11008	12228-FLEN
VKM11010	1806-M
VKM11010	1806-MI
VKM11014	1104-A
VKM11014	1104-AI
VKM11018	12595-FLEN
VKM11020	1808-M
VKM11021	1129-FLEN
VKM11072	12241-MI
VKM11073	12578-FLEN
VKM11106	12283-AI
VKM11113	1157-FLEN
VKM11113	1157-AI
VKM11116	12240-NTN
VKM11116	12240-FLEN
VKM11120	12549-AI
VKM11130	1107-A
VKM11142	12239-AI
VKM11143	12484-FLEN
VKM11150	12570-FLEN
VKM11202	12480-MI
VKM11222	12573-FLEN
VKM11250	12458-AI
VKM11255	12598-FLEN
VKM11257	12580-FLEN
VKM11258	12319-PI
VKM11265	12592-FLEN
VKM11266	12590-FLEN
VKM12001	12500-M
VKM12003	1872-M
VKM12003	1872-MI
VKM12005	1823-M
VKM12005	1823-MI
VKM12012	1852-M
VKM12100	1855-M
VKM12100	1855-MI
VKM12101	1818-M
VKM12101	1818-MI
VKM12103	1851-M
VKM12103	1851-MI
VKM12151	1819-M
VKM12151	1819-MI

VKM12153	1835-M
VKM12153	1835-MI
VKM12172	1113-FLEN
VKM12172	1113-AI
VKM12173	12090-A
VKM12173	12090-AI
VKM12174	1115-A
VKM12174	1115-AI
VKM12182	12354-AI
VKM12200	1822-M
VKM12200	1822-MI
VKM12200	1822-FLEN
VKM12201	12155-A
VKM12201	12155-AI
VKM12227	1832-MD
VKM12227	1832-MI
VKM12242	12091-A
VKM12242	12091-AI
VKM12277	12315-AI
VKM12299	12455-INA
VKM12380	1816-M
VKM12500	1800-FLEN
VKM12500	1800-MI
VKM12501	1801-FLEN
VKM12501	1801-MI
VKM12630	1825-M
VKM13100	1811-M
VKM13100	1811-MI
VKM13120	1861-MI
VKM13130	1121-M
VKM13132	12451-INA
VKM13132	12451-AI
VKM13200	1812-MI
VKM13202	1943-KOY
VKM13202	1943-MI
VKM13210	1869-M
VKM13210	1869-MI
VKM13211	1911-P
VKM13211	1911-Compl
VKM13211	12276-MI
VKM13214	92100-FLEN
VKM13214	92100-MI
VKM13220	12156-M
VKM13234	12334-AI
VKM13240	1813-MI
VKM13240 Rep	32011-AL
VKM13240 Rep	32011-CH
VKM13241 Rep	32011-AL
VKM13241 Rep	32011-CH
VKM13241	1901-M
VKM13241	1901-MI
VKM13244	1118-M
VKM13244	1118-PI
VKM13246	12093-M
VKM13246	12093-PI
VKM13250	1871-FLEN

VKM13250	1871-MI
VKM13253	12376-AI
VKM13256	12551-FLEN
VKM13257	12522-AI
VKM13300	1944-M
VKM13304	12243-INA
VKM13900 Rep	1161-M
VKM13900 Rep	1161-MI
VKM13902	12465-SKF
VKM14000	1839-MD
VKM14000	1839-MI
VKM14001	12297-AI
VKM14100	12162-PI
VKM14103	1915-MI
VKM14105	1985-M
VKM14105	1985-MI
VKM14107	1099-A
VKM14107	1099-AI
VKM14108	12454-SNR
VKM14108	12454-MI
VKM14201	1837-FLEN
VKM14201	1837-MI
VKM14210	1903-PI
VKM14211	12169-A
VKM14222	12505-AI
VKM14300	12168-M
VKM14301	1842-MI
VKM15121	1948-A
VKM15121	1948-AI
VKM15202	1100-A
VKM15202	1100-AI
VKM15213	12384-MI
VKM15214	1102-A
VKM15214	1102-AI
VKM15215	1126-M
VKM15216	12275-AI
VKM15218	12457-A
VKM15402	1101-A
VKM15402	1101-AI
VKM16000	1863-M
VKM16000	1863-MI
VKM16001	1145-M
VKM16001	1145-MI
VKM16020	12177-A
VKM16020	12177-AI
VKM16021	12593-AI
VKM16100	1581-FLEN
VKM16101	1173-M
VKM16101	1173-MI
VKM16101	1865-M
VKM16101	1865-MI
VKM16102	12298-A
VKM16102	12298-AI
VKM16112	1880-M
VKM16112	1880-MI
VKM16200	1817-M

VKM16200	1817-MI
VKM16204	1882-M
VKM16204 Rep	22011-AL
VKM16204 Rep	22011-M
VKM16210	1858-M
VKM16210	1858-MI
VKM16212	1913-M
VKM16212	1913-MI
VKM16212 Rep	22010-AL
VKM16212 Rep	22010-CH
VKM16300	12587-FLEN
VKM16410	12585-FLEN
VKM16501	1112-FLEN
VKM16501	1112-AI
VKM16503	FS-05492
VKM16550	12261-AI
VKM16551	12201-A
VKM16551	12201-AI
VKM16600 Rep	12207-FLEN
VKM16600 Rep	12207-FLEN
VKM16602	1930-FLEN
VKM16602 Rep	1930-Rep
VKM16604	1137-FLEN
VKM16604	1137-MI
VKM17000	1897-FLEN
VKM17200	1896-NACH
VKM17300	1895-FLEN
VKM17302	12432-MI
VKM17303	12433-MI
VKM17310	1894-NTN
VKM17310	1894-MI
VKM17406	1968-MD
VKM17406	1968-MI
VKM18000	12489-FLEN
VKM18001	12488-FLEN
VKM18100	12487-FLEN
VKM18200	12190-M
VKM21004	1131-FLEN
VKM21004	1131-M
VKM21004	1131-MI
VKM21012	1128-FLEN
VKM21012	1128-M
VKM21012	1128-MI
VKM21031	52004-P
VKM21045	12589-FLEN
VKM21115	12242-NTN
VKM21115	12242-AI
VKM21120	12438-PI
VKM21121	12440-MI
VKM21130	1166-M
VKM21130	1166-MI
VKM21131	1167-RT
VKM21131	1167-M
VKM21131	1167-MI
VKM21142	12238-FLEN
VKM21142	12238-M

VKM21147	12474-M
VKM21151	12575-FLEN
VKM21202	12479-FLEN
VKM21203	12576-FLEN
VKM21220	12478-M
VKM21256	12596-M
VKM22151	1820-M
VKM22151	1820-MI
VKM22153	1889-M
VKM22153	1889-MI
VKM22173	1938-MI
VKM22174	1950-MI
VKM22177	12204-MI
VKM22177	12393-PI
VKM22242	1951-M
VKM22242	1951-MI
VKM22380	1821-M
VKM22380	1821-MI
VKM22385	1816-M
VKM22385	1816-MI
VKM22510	1937-FLEN
VKM22510	1937-PI
VKM22540	12152-MD
VKM22630	1840-M
VKM22630	1840-MI
VKM23120	1862-MI
VKM23130	1122-M
VKM23130	1122-MI
VKM23140	12377-PI
VKM23230	92102-M
VKM23240	1814-M
VKM23241	1900-M
VKM23241	1900-MI
VKM23241 Rep	32031-AL
VKM23241 Rep	32031-CH
VKM23244	1119-MD
VKM23244	1119-PI
VKM23246	12094-M
VKM23246	12094-PI
VKM23256	12594-M
VKM23300	1945-M
VKM23304	12272-INA
VKM23304	12272-MD
VKM23900	1170-MD
VKM23901	1171-MD
VKM24100	1902-M
VKM24100	1902-MI
VKM24107	1123-M
VKM24107	1123-MI
VKM24210	1904-M
VKM24210	1904-MI
VKM24211	1096-M
VKM24211	1096-PI
VKM24212	12157-MI
VKM24213	12167-P
VKM24213	12167-PI

VKM24214	12166-M
VKM24214	12166-MI
VKM25150	1952-AL
VKM25150	1952-PI
VKM25152	1953-AL
VKM25152	1953-PI
VKM25202	1909-FLEN
VKM25202	1909-MI
VKM25210	1878-M
VKM25210	1878-MI
VKM25212	1906-AL
VKM25212	1906-MI
VKM25213	1907-AL
VKM25213	1907-MI
VKM25224	1127-AL
VKM25224	1127-PI
VKM25312	12386-MI
VKM26020	12208-P
VKM26020	12208-PI
VKM26100	12582-FLEN
VKM26101	1854-MD
VKM26101	1854-MI
VKM26102	1881-M
VKM26102	1881-MI
VKM26105	12246-PI
VKM26114	1147-M
VKM26115	1148-M
VKM26115	1148-MI
VKM26123	1146-M
VKM26125	1153-M
VKM26128	12425-M
VKM26211	1857-AL
VKM26211	1857-MI
VKM26212	12173-M
VKM26310	12424-PI
VKM26400	15584-FLEN
VKM26402	12583-FLEN
VKM26500	12429-MI
VKM26501	1965-AL
VKM26501	1965-MI
VKM26503	FU-15492
VKM26600	12199-M
VKM26602	12200-NSK
VKM26612	12198-M
VKM27404	1892-MD
VKM27404	1892-MI
VKM27404	12164-M
VKM27404	12164-MI
VKM28000	FU-17999
VKM28001	FU-19990
VKM31002	1174-PI
VKM31004	3104-P
VKM31004	3104-PI
VKM31007	FU-20996
VKM31010	FU-20909
VKM31010	14030-FLEN

A SKF

SKF NUMBER

CÓDIGO SKF **CÓDIGO EM** **CÓDIGO SKF** **CÓDIGO EM** **CÓDIGO SKF** **CÓDIGO EM**

CÓDIGO SKF **CÓDIGO EM** **CÓDIGO SKF** **CÓDIGO EM** **CÓDIGO SKF** **CÓDIGO EM**

VKM31011	12258-AI
VKM31012	12361-AI
VKM31013	12459-AI
VKM31013 Rep	12453-PI
VKM31015	12450-AI
VKM31016	12602-AI
VKM31018	FA-20907
VKM31019	FA-99049
VKM31023	FA-20912
VKM31033	12256-AI
VKM31034	12452-AI
VKM31041	12605-M
VKM31059	12362-MI
VKM31061	12257-AI
VKM31210	FA-99048
VKM32001	3201-AL
VKM32001	3201-PI
VKM32002	3202-PI
VKM32002	3202-M
VKM32003	12357-PI
VKM32004	1124-M
VKM32005	3205-PI
VKM32006	3206-P
VKM32006	3206-PI
VKM32009	1187-AL
VKM32009	1187-PI
VKM32009	12012-AL
VKM32010	12041-M
VKM32015	3215-MI
VKM32016	3216-P
VKM32022	12353-AI
VKM32023	12460-AI
VKM32027	12352-AI
VKM32030	12356-PI
VKM32031	12339-AL
VKM33002	1931-M
VKM33002	1931-MI
VKM33004	3304-M
VKM33004	3304-MI
VKM33005	3305-AL
VKM33005	3305-CH
VKM33006	32018-AL
VKM33006	32018-CH
VKM33008	3308-M
VKM33008 Rep	32002-AL
VKM33009	1133-INA
VKM33009 Rep	12464-MI
VKM33010	1849-M
VKM33011	3311-MI
VKM33012	1125-MI
VKM33013	3313-M
VKM33013	3313-MI
VKM33013	32013-M
VKM33014	3314-MI
VKM33015	1095-MI
VKM33016	3316-INA

VKM33017	3317-MI
VKM33018	32014-C
VKM33018 Rep	32014-M
VKM33019	12446-GAT
VKM33019	12446-AI
VKM33020	3320-PI
VKM33023	32035-CH
VKM33023	32035-MI
VKM33023	32035-AL
VKM33026 Rep	32053-AL
VKM33027 Rep	32052-AL
VKM33027 Rep	32052-CH
VKM33028	12260-AI
VKM33028 Rep	32054-AL
VKM33029	32005-MI
VKM33029 Rep	32004-CH
VKM33029 Rep	32006-CH
VKM33031	12374-PI
VKM33032	12373-AI
VKM33033	12375-AI
VKM33033 Rep	32051-AL
VKM33033 Rep	32051-CH
VKM33034	32009-CH
VKM33035 Rep	32055-AL
VKM33035 Rep	32055-CH
VKM33037	32025-M
VKM33037	12330-INA
VKM33037	12330-MI
VKM33037 Rep	32026-AL
VKM33038	12244-INA
VKM33040	E1492-M
VKM33043	12447-DAY
VKM33045	12372-PI
VKM33061	12448-DAY
VKM33101	12270-LIT
VKM33311	12350-AMO
VKM34004	12213-INA
VKM34004	12213-MI
VKM34004 Rep	3404-AL
VKM34004 Rep	3404-CH
VKM34004 Rep	42013-AL
VKM34004 Rep	42013-CH
VKM34005 Rep	3405-AL
VKM34005	12311-MI
VKM34010 Rep	12161-P
VKM34010 Rep	12161-M
VKM34010	12456-AI
VKM34034	42001-AL
VKM34034	42001-AL
VKM34034	42001-AL
VKM34042	12336-MI
VKM34043	12337-MI
VKM34108	12449-LIT
VKM35002	3502-M
VKM35002	3502-PI
VKM35007	12253-INA

VKM35007 Rep	12247-AL
VKM35008	13108-A
VKM35008 Rep	62001-A
VKM35009	12266-AI
VKM35009	12444-AI
VKM35009 Rep	62001-CH
VKM35011	12265-AI
VKM35012	12267-AI
VKM35016	12172-AL
VKM36001	1144-M
VKM36003	1143-P
VKM36004	1135-SKF
VKM36004	1135-MI
VKM36005	1150-M
VKM36005	1150-MI
VKM36006	1139-M
VKM36006	1139-PI
VKM36007	1134-MI
VKM36008	12273-INA
VKM36008	12273-MI
VKM36009	1136-MI
VKM36010	1149-M
VKM36010	1149-MI
VKM36011	12274-M
VKM36011	12274-INA
VKM36012	1142-M
VKM36012 Rep	22006-M
VKM36013	1138-CH
VKM36013	3613-AL
VKM36014	1141-M
VKM36014	1141-MD
VKM36014	1141-MDI
VKM36016	1151-M
VKM36017	12607-M
VKM36018	1152-AI
VKM36019	12176-M
VKM36022	3622-M
VKM36023	3623-PI
VKM36025	22031-M
VKM36025	22031-PI
VKM36026 Rep	12331-INA
VKM36026 Rep	22018-AL
VKM36026 Rep	22018-CH
VKM36032 Rep	22026-AL
VKM36032 Rep	22026-CH
VKM36035	12320-A
VKM36035	12320-AI
VKM36040	12428-PI
VKM36080	12175-M
VKM36120 Rep	22014-AL
VKM38001	12181-P
VKM38003	FU-27992
VKM38004	12193-P
VKM38006	FA-27995
VKM38007	FA-27994
VKM38012	12182-P

VKM38012	FD27905
VKM38020	12604-AI
VKM38022	FS-27911
VKM38022	14021-FLEN
VKM38026	FS-27915
VKM38026	14020-FLEN
VKM38027	FS-27916
VKM38027	14017-FLEN
VKM38100	FS-27099
VKM38202	FA-99138
VKM38220	FS-99121
VKM38225	FU-99112
VKM38230	12318-MI
VKM51001	12180-M
VKM70000	12214-MI
VKM70001	12268-AI
VKM71001	1988-MI
VKM71002	1013-MI
VKM71003	12183-MI
VKM71007	12254-FLEN
VKM71007	12254-MI
VKM71014	1176-MI
VKM71100	12184-MI
VKM71101	12186-MI
VKM71202	12216-FLEN
VKM71202	12216-NACH
VKM72000	12215-FLEN
VKM72000	12215-KOY
VKM72004	12217-FLEN
VKM72004	12217-MI
VKM72200	12326-NSK
VKM72320	12535-MI
VKM72500	12312-MI
VKM73000	1927-MI
VKM73002	12219-MI
VKM73005	12509-MI
VKM73008	12211-NTN
VKM73011	1178-KOY
VKM73101	12511-MI
VKM73200	12218-MI
VKM73201	12510-MI
VKM73600	1905-MI

VKM74001	12220-NACH
VKM74001	12220-MI
VKM74004	12221-FLEN
VKM74006	12325-NSK
VKM74008	12196-KOY
VKM74200	12410-MI
VKM74201	12222-FLEN
VKM74201	12222-MI
VKM74300	12527-MI
VKM74310	12525-MI
VKM74501	12526-MI
VKM74600	12223-FLEN
VKM74600	12223-MI
VKM75000	12341-MI
VKM75001	12413-MI
VKM75004	12227-NSK
VKM75006	12224-MI
VKM75008	12531-MI
VKM75009	12226-KOY
VKM75033	12305-NSK
VKM75044	12206-FLEN
VKM75044	12206-MI
VKM75054	12328-NSK
VKM75100	12400-MI
VKM75101	12279-MI
VKM75108	12280-MI
VKM75113	12401-MI
VKM75119	12415-MI
VKM75130	12416-MI
VKM75140	12530-MI
VKM75144	12194-FLEN
VKM75144	12194-MI
VKM75601	1061-M
VKM75601	1061-MI
VKM75612	1184-M
VKM75612	1184-MI
VKM75613	12528-MI
VKM75615	12322-NSK
VKM75616	12323-NSK
VKM75629	12195-M
VKM76001	12229-KOY
VKM76001	12229-MI

VKM76102	12329-MI
VKM76102	12387-MI
VKM76103	12281-FLEN
VKM76200	12230-NTN
VKM76202	12210-FLEN
VKM76203	12231-NTN
VKM76521	12277-NSK
VKM77100	12310-NTN
VKM77300	12232-MI
VKM77401	12495-MI
VKM77500	12233-NACH
VKM78000	12225-MI
VKM78105	12304-NTN
VKM79000	12282-NSK
VKM79001	12255-MI
VKM80000	12234-MI
VKM81001	1989-MI
VKM81002	1014-MI
VKM81002	1014-PI
VKM81004	12187-MI
VKM81100	12205-FLEN
VKM81100	12205-MI
VKM81201	12340-NSK
VKM82000	12552-MI
VKM82001	12553-MI
VKM82101	12541-MI
VKM82300	12542-PI
VKM82302	12308-NSK
VKM82500	VKM82500
VKM82501	VKM82501
VKM84201	VKM84201
VKM84201	VKM84201
VKM84310	VKM84310
VKM84600	VKM84600
VKM84601	VKM84601
VKM85000	VKM85000
VKM85002	VKM85002
VKM85140	VKM85140
VKM88000	VKM88000
VKM88001	VKM88001
VKM89003	VKM89003

IMPORTANTE: Todos los códigos de EM EUROMOTOR que comienzan con FA, FD, FS o FU corresponden a tensores FLENNOR. Los precios de los mismos se deben buscar en la **Lista de Tensores FLENNOR**.

IMPORTANT: All the EM EUROMOTOR codes that begin with FA, FD, FS or FU are FLENNOR tensioners. The price of these tensioners must be searched in the **FLENNOR price list**.

CÓDIGO INA **CÓDIGO EM** **CÓDIGO INA** **CÓDIGO EM** **CÓDIGO INA** **CÓDIGO EM**

531055120	14017-FLEN
531059230	FA-99048
532040430	32058-M
534011420	14020-FLEN
534017910	12270-LIT
FI10273.2A	1823-M
FI10273.2A	1823-MI
FI10590.1	1819-M
FI10590.1	1819-MI
FI10591.1	1820-M
FI10591.1	1820-MI
FI10627.3	1187-AL
FI10627.3	1187-PI
FI10627.4	1187-PI
FI10628.3	1951-M
FI10628.3	1951-MI
FI10672.300	3205-PI
FI10790	12012-AL
FI10790	12012-M
FI10806.2	12455-M
FI10811.2	3502-AL
FI10811.2	3502-PI
FI10911	3205-PI
FI10937	1915-MI
FI13338	1816-M
FI13338	1816-MI
FI13339	1821-M
FI13339	1821-MI
FI20046.4	1869-M
FI20046.4	1869-MI
FI20180	1880-M
FI20180	1880-MI
FI20243.9	3306-AL
FI20243.9	3306-CH
FI20552	12156-MI
FI20627	1871-FLEN
FI20627	1871-MI
FI20726	1882-M
FI20808	1138-CH
FI20808	3613-AL
FI20850	1138-CH
FI20850	3613-AL
FI20959.1	1811-M
FI20992.1	1913-M
FI21271 Rep	22006-M
FI21271.1	1142-M
FI21287	1811-M
FI21287.1	1811-M
FI21287.5	1811-M
FI21338.5	1124-M
FI21366	1139-M
FI21366	1139-PI
FI21373.1	33018-CH
FI21450.8	3316-INA
FI21531	3311-MI
FI21538	12173-M

FI21586	1141-M
FI21586	1141-MD
FI21586	1141-MDI
FI21722	3314-MI
FI21772.3	1911-Compl
FI21772.3	12276-MI
FI21792	1944-M
FI21793	1945-M
FI21977.1	1095-MI
FI22051	1813-MI
FI22124	1862-M
FI22124.2	1862-MI
FI22216.3	1901-M
FI22216.3	1901-MI
FI22216.3 Rep	1901-MI
FI22216.3 Rep	1901-MI
FI22385.10	12243-INA
FI22387.2	12272-INA
FI22387.2	12272-MD
FI22424.5	1133-INA
FI22424.5 Rep	12464-MI
FI22481.6	1150-M
FI22481.6	1150-MI
FI22481.8	1149-M
FI22481.8	1149-MI
FI22530.12	1151-M
FI22544	3308-M
FI22544 Rep	32002-AL
FI22544 Rep	32002-CH
FI22574	1122-M
FI22576	1121-M
FI22598	1125-MI
FI22598.05	1125-MI
FI22649	1125-MI
FI22661	3305-CH
FI22661.1	3305-CH
FI22662	3313-M
FI22662	3313-MI
FI22662.6	3213-M
FI22676.51	22031-M
FI22676.51	22031-PI
FI22677.2	12244-INA
FI22677.2 Rep	12244-INA
FI22702.7	32056-M
FI22702.50	32056-M
FI22710.3	22010-AL
FI22710.3	22010-CH
FI22748.11	32014-C
FI22868	1943-KOY
FI22868	1943-MI
FI22910	1861-MI
FI22980	1900-M
FI22980	1900-MI
FI22980 Rep	32031-AL
FI22980 Rep	32031-CH
FI22985.5	1118-M

FI22985.5	1118-PI
FI22985.51	12093-M
FI22985.51	12093-PI
FI22986.5	12094-M
FI22986.5	12094-PI
FI22986.6	1119-MD
FI22986.6	1119-PI
FI22990.6	12175-CH
FI23000	1931-M
FI23000	1931-MI
FI23035	1147-M
FI23132	1854-MD
FI23132	1854-MI
FI23137	12429-MI
FI23139	12274-M
FI23139	12274-INA
FI23140	12273-INA
FI23140	12273-MI
FI23142	12159-M
FI23142	12159-MI
FI23142	1965-AL
FI23142	1965-MI
FI23144	3622-M
FI23145	12176-M
FI23147	1150-M
FI23147	1150-MI
FI23147.02	1149-M
FI23147.02	1149-MI
FI23148	3623-PI
FI23149	1913-M
FI23149	1913-MI
FI23150	1882-M
FI23150 Rep	22011-AL
FI23150 Rep	22011-M
FI23154.3	1145-M
FI23154.3	1145-MI
FI23190	12245-MI
FI23225	1863-M
FI23259.1	32035-MI
FI23259.1	32035-AL
FI23259.1	32035-CH
FI23305.1	3304-M
FI23305.1	3304-MI
FI23368.1 Rep	1813-MI
FI23368.1 Rep	32011-AL
FI23368.1 Rep	32011-CH
FI23369	1814-M
FI23469.10	FU-15492
FI23474	12606-MD
FI23475	1881-M
FI23475	1881-MI
FI23630	12500-M
FI23631	1872-M
FI23631	1872-MI
FI23634	1855-M
FI23634	1855-MI

CÓDIGO INA **CÓDIGO EM** **CÓDIGO INA** **CÓDIGO EM** **CÓDIGO INA** **CÓDIGO EM**

FI23635	1851-M
FI23637	1835-M
FI23637	1835-MI
FI23638	1832-MD
FI23638	1832-MI
FI23640	1800-FLEN
FI23640	1800-MI
FI23641	1801-FLEN
FI23641	1801-MI
FI23642	1915-MI
FI23643	12168-M
FI23648	12190-M
FI23650	1889-M
FI23650	1889-MI
FI23653	1938-MI
FI23654	1878-M
FI23654	1878-MI
FI23657	12308-MI
FI23659	FU-99112
FI23660	1134-MI
FI23661	1135-SKF
FI23661	1135-MI
FI23662	12338-MI
FI23663	1136-MI
FI23697	1951-M
FI23732	1146-M
FI23736	E1492-M
FI23746	12260-AI
FI23746 Rep	32054-AL
FI23747	12353-AI
FI23749	32009-CH
FI23760	32053-AL
FI23761 Rep	32055-AL
FI23761 Rep	32055-CH
FI23762 Rep	32052-AL
FI23762 Rep	32052-CH
FI23775	1149-M
FI23775	1149-MI
FI23776	1173-M
FI23776	1173-MI
FI23777	1153-M
FI23778	12208-P
FI23778	12208-PI
FI23779	1148-M
FI23779	1148-MI
FI23780	FS-99121
FI23781	12424-PI
FI23783	1143-P
FI23787	32005-M
FI23787	32005-MI
FI23787 Rep	32004-AL
FI23787 Rep	32004-CH
FI23787 Rep	32006-AL
FI23787 Rep	32006-CH
FI23788	12351-AMO
FI23792	12330-INA

FI23792	12330-MI
FI23792	32025-M
FI23792 Rep	32026-AL
FI23794	12537-mi
FI23795	1152-AI
FI23796	12326-MI
FI23800	3215-MI
FI23803	1950-M
FI23804	1937-FLEN
FI23804	1937-PI
FI23805	1927-MI
FI23806	12384-MI
FI23807	1129-AI
FI23811	12511-MI
FI23814	1157-FLEN
FI23814	1157-AI
FI23815	1126-M
FI23816	1906-AL
FI23816	1906-MI
FI23880	3317-MI
FI23880.2	3317-MI
FI23906.4	12377-PI
FI23958	1863-M
FI23958	1863-MI
FI23996	12184-MI
FI23997	12205-MI
FI24000 Rep	22018-AL
FI24000 Rep	22018-CH
FI24001	12331-INA
FI24047	12535-MI
FI24048	12280-MI
FI24049	12538-MI
FI24050	12325-MI
FI24051	12210-MI
FI24052	1184-M
FI24052	1184-MI
FI24053	12400-MI
FI24055	12229-MI
FI24058	12350-AMO
FI24059	22026-AL
FI24060	1988-MI
FI24061	1989-MI
FI24062	12186-MI
FI24063	12216-MI
FI24064	12556-MI
FI24065	12215-MI
FI24066	12220-MI
FI24067	12526-MI
FI24068	12223-MI
FI24069	12305-MI
FI24070	1061-M
FI24070	1061-MI
FI24071	1989-M
FI24072	12187-MI
FI24073	12340-MI9
FI24074	12558-MI

FI24075	12514-MI
FI24076	12279-MI
FI24087	12560-MI
FI24090	12222-MI
FI24091	1075-MI
FI24092	12227-MI
FI24099	1171-M
FI24144	3305-CH
FI24197.4	12317-AL
FI24276.1	92102-M
FI24291	FU-15492
FI24284	12425-M
FI25024	12525-MI
FI25030	12312-MI
FI25031	12313-MI
FI25032	12183-M
FI25039	12445-AI
FI25039 Rep	22025-AL
FI25039 Rep	22025-CH
FI25042	12376-AI
FI25046	14033-FLEN
FI25050	12446-GAT
FI25050	12446-AI
FI25051	3320-PI
FI25052	12311-MI
FI25056	12456-AI
FI25060	12239-AI
FI25061	FD-99004
FI25064	12228-FLEN
FI25067	12240-AI
FI25066	12573-FLEN
FI25068	FD-99199
FI25079	92100-FLEN
FI25079	92100-MI
FI25082	12298-AI
FI33397.8	12246-PI
FI40055	1837-FLEN
FI40055	1837-MI
FI40056	1842-MI
FI40057.1	12162-PI
FI40057.2	1985-M
FI40057.2	1985-MI
FI40064	1894-NTN
FI40064	1894-MI
FI40065.1	1895-MI
FI40070	12164-M
FI40070	12164-MI
FI40070.1	1892-MD
FI40070.1	1892-MI
FI40073.3	1902-M
FI40073.3	1902-MI
FI40079.1	12192-P
FI40080.1	12431-PI
FI40221	1903-PI
FI40222	1904-M
FI40222	1904-MI

CÓDIGO INA **CÓDIGO EM** **CÓDIGO INA** **CÓDIGO EM** **CÓDIGO INA** **CÓDIGO EM**

F140223	1096-M
F140223	1096-PI
F140564	12163-M
F140564.1	1968-MD
F140564.1	1968-MI
F140827	12432-MI
F140845.1	1123-M
F140845.1	1123-MI
F140914	12092-A
F140931.06	12169-A
F143003	12333-PI
F143108	12433-MI
F203124.1	12182-PI
F203124.1	12182-FLEN
F205859	FS-99093
F205859	14015-FLEN
F206747.6	12489-FLEN
F207109.2	FU-17990
F209636.9	FU-27992
F211941.4	FU-17999
F212272.1	E1492-M
F212600.7	12198-M
F212600.7	12591-FLEN
F214797	3104-P
F214797	3104-PI
F214797.6	3104-PI
F217668.2	1805-M
F217668.2C	1805-M
F218108	1906-PI
F218108.4	1906-PI
F218108.5	1906-PI
F218472	12488-FLEN
F218740.1	1952-PI
F218740.3	1952-PI
F218740.4	1952-PI
F218740.5	1952-PI
F218741.1	1953-PI
F218741.3	1953-PI
F218741.5	1953-PI
F218800	12250-LIT
F218999	12587-FLEN
F219476	FU-17999
F219949	12181-P
F220083	1808-M
F220084	12489-FLEN
F220085	FU-17999
F220090.1	FU-27992
F220092	12182-PI
F220093	1805-M
F220093	1805-MI
F220094.1	FU-27992
F220095	1806-M
F220095	1806-MI
F220096	52004-P
F220122	FS-99093
F220122	14015-FLEN

F220122.1	FS-99093
F220122.1	14015-FLEN
F220134	FS-99151
F220256	12488-FLEN
F220257	1818-M
F220257	1818-MI
F220259.2	12193-P
F220279	FS-99172
F220279	14016-FLEN
F220283	12583-FLEN
F220285	12585-FLEN
F220286	12583-FLEN
F220289	FU-99152
F220290	FU-99156
F220292	FU-20909
F220292	14030-FLEN
F220323	12389-MI
F221646.100	FA-27995
F222651	1128-FLEN
F222651	1128-M
F222651	1128-MI
F224134	3502-M
F224134	3502-PI
F224669.2	32009-CH
F224693	1930-FLEN
F224963	1909-FLEN
F224963	1909-MI
F224964	1906-PI
F224964	1906-PI
F224966	1907-AL
F224966	1907-MI
F224967	1952-PI
F224971	1953-AL
F224971	1953-PI
F225355.5	12251-INA
F225355.5	12251-PML
F225355.7	12251-PML
F225532	12199-M
F225570	FS-99183
F225570	14006-FLEN
F225571	FS-99182
F225571	14004-FLEN
F225644.5	12290-PML
F225644.7	12290-PML
F225653.6	12286-PML
F225766	12589-M
F225766.1	12589-M
F226668.2	12172-AL
F227194.1	12297-AI
F227242	1131-FLEN
F227242	1131-M
F227242	1131-MI
F227243	1166-M
F227243	1166-MI
F227252.100	FD-99146
F227617.100	12351-AMO

F227628.5	12252-INA
F227628.5	12252-PML
F227628.7	12287-PML
F228533	12198-M
F228533	12591-M
F228824.10	12289-PML
F228881.3	12301-PML
F229515	12318-PI
F229518	12318-PI
F229603.11	12292-PML
F230025	12002-CH
F230093.2	FS-05492
F230206	FA-99138
F230208	FA-99123
F230209	12293-PML
F230759.2	12291-PML
F230866.10	12285-PML
F230875	12362-MI
F231069	12605-M
F231069	12161-P
F231069	12161-M
F231071	12604-AI
F231072	FS-27911
F231072	14021-FLEN
F231098	12393-PI
F231127	12253-INA
F231127 Rep	12247AL
F231137	12157-MI
F231218	12550-AI
F231219	12438-PI
F231220	12440-MI
F231221.1	12549-AI
F231223	1167-RT
F231223	1167-M
F231223	1167-MI
F231224	FU-20996
F231231	12479-FLEN
F231285.3	FS-99257
F231289.300	12193-MI
F231339	FS-99258
F231413	1127-AL
F231413	1127-AL
F232477	1115-A
F232477	1115-AI
F232481	1102-A
F232481	1102-AI
F232482	1948-A
F232482	1948-AI
F232486	1104-A
F232486	1104-AI
F232488	1100-A
F232488	1100-AI
F232489	12283-AI
F232604	1107-A
F232828.3	12522-AI
F232829.4	12451-AI

CÓDIGO INA **CÓDIGO EM** **CÓDIGO INA** **CÓDIGO EM** **CÓDIGO INA** **CÓDIGO EM**

F232829.5	12551-FLEN
F233593.1	12288-PML
F233369.100	FA-27994
F233748.11	32014-C
F233748.11 Rep	32014-M
F233867	12167-M
F233878.1	1137-FLEN
F233878.1	1137-MI
F233879	12167-M
F234055 Rep	22014-AL
F234062	1112-FLEN
F234062	1112-AI
F234389	12241-MI
F234391	1099-A
F234391	1099-AI
F234392	12090-A
F234392	12090-AI
F234394	1101-A
F234394	1101-AI
F234395	12578-FLEN
F234709	12459-AI
F234709.300	12453-PI
F234845	12238-FLEN
F234845	12238-M
F234846	12576-M
F234847	12482-M
F234848	12577-M
F235779	12319-PI
F235780	12580-M
F235781	FA-99010
F235782	12258-AI
F235783	12266-AI
F235783 Rep	62001-CH
F235784	12444-AI
F235785	13108-A
F235785 Rep	62001-A
F235786	12450-AI
F235786.01	12450-AI
F236501	12575-FLEN
F236389	12299-AI
F236654	12603-AI
F236655	12356-PI

F236658	12265-AI
F236660	12357-PI
F236663	12460-AI
F236665	12352-AI
F236666	12375-AI
F236666 Rep	32051-AL
F236666 Rep	32051-CH
F236667	12374-PI
F236667	32043-AL
F236667	32043-CH
F236668	12373-AI
F236854	12155-A
F236854	12155-AI
F237801	12214-MI
F237803	1113-AI
F237804	12261-AI
F237843	FS-05492
F238071	12454-FLEN
F238071	12454-AI
F238349	12201-A
F239421	12596-M
F239652	12474-M
F239676	12600-A
F239678	12463-AI
F239686	12339-AL
F239960	12246-P
F36261	1822-M
F36261.3	1822-M
F36261.3	1822-MI
F37629	1817-M
F37629	1817-MI
F37630.1	1858-M
F37630.1	1858-MI
F37734.2	1857-AL
F37734.2	1857-MI
F38153	12582-FLEN
F38317.C	1812-MI
F38931	1849-M
F38931.4	1849-M
F38931.4 Rep	32015-P
F38950	12581-FLEN

F39508.5	1865-M
F39508.5	1865-MI
F39924.10	1863-M
F44573	E1451-M
F44818.2	42007-M
F45398	12027-AL
F45442	1825-M
F45442.2	1825-M
F45605	1840-M
F45605	1840-MI
F49974.10	12333-PI
F550126	12297-AI
F550217	12167-M
F550228	12177-A
F550228	12177-AI
F550461	12268-AI
F550492	12256-AI
F550810	12361-AI
F550811	12257-AI
F550812	12283-FLEN
F551224	1107-AI
F551227	12490-FLEN
F551286	12458-AI
F55172	12587-FLEN
F551823	FA-20912
F551837	12602AI
F552258	12596-M
F554653	1176-MI
F556090	12091-A
F556090	12091-AI
F56900	1839-MD
F631153	1144-M
F68768.3	12180-M
F81749.1	1805-M
F81749.2	1805-M
F81749.5	1805-M
F82798	1839-MD
F82302	12487-FLEN
F82302.9	12487-FLEN
F88019.2	12389-MI
F90053.4	1806-M

IMPORTANTE: Todos los códigos de EM EUROMOTOR que comienzan con FA, FD, FS o FU corresponden a tensores FLENNOR. Los precios de los mismos se deben buscar en la **Lista de Tensores FLENNOR**.

IMPORTANT: All the EM EUROMOTOR codes that begin with FA, FD, FS or FU are FLENNOR tensioners. The price of these tensioners must be searched in the **FLENNOR price list**.

EM euromotor®

VERSION PDF 2010



Ø18

FOTOS DE TENSORES *TENSIONER PHOTOGRAPHS*

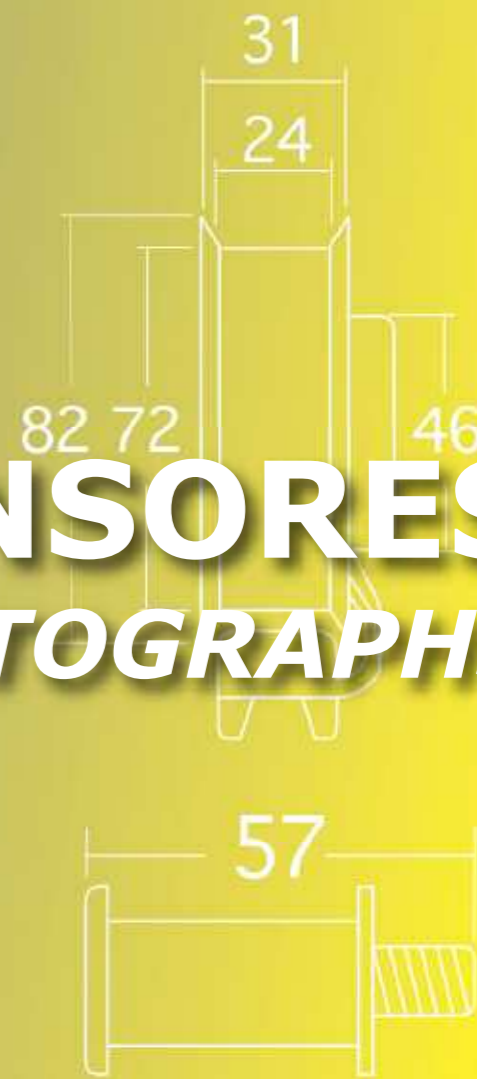





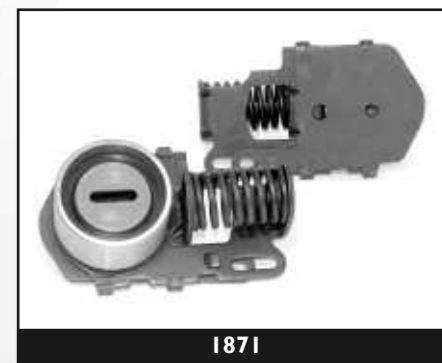

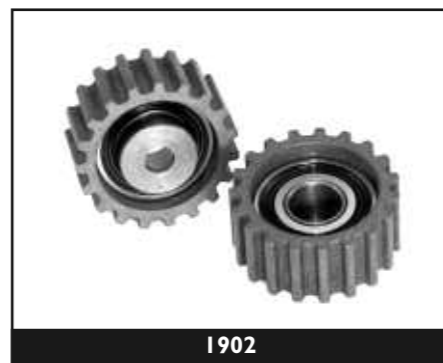











I2415



I2416



I2424



I2425



I2429



I2432



I2433



I2438



I2440



I2451



I2454



I2455



I2457



I2458



I2465



I2467



I2468

Producto no disponible
al momento de la confección
de este catálogo.

Product not available
when this catalogue
was made.

I2469



I2474



I2475



I2476



I2477



I2478



I2479



I2480



I2481



I2482



I2483



I2484



I2485



12486



12487



12488



12489



12490



12491

Producto no disponible al momento de la confección de este catálogo.
Product not available when this catalogue was made.

12492



12494



12495



12496



12497



12498



12500



12503



12504



12505



12507



12508



12509



12510



12511

Producto no disponible al momento de la confección de este catálogo.
Product not available when this catalogue was made.

12513



12514



12515



12516



12517



12518



12519



12520



12522



I2523



I2524



I2525



I2526



I2527



I2528



I2529



I2530



I2531



I2532



I2533



I2534



I2535



I2536



I2537



I2538



I2539



I2540



I2541



I2542



I2543



I2544



I2545



I2546



I2547



I2549



I2550



I2551



I2552



I2553

FOTO TENSORES

TENSIONER PHOTOGRAPHS







FS00049



FS05492



FS99012



FS99151



FU15492



FU99152

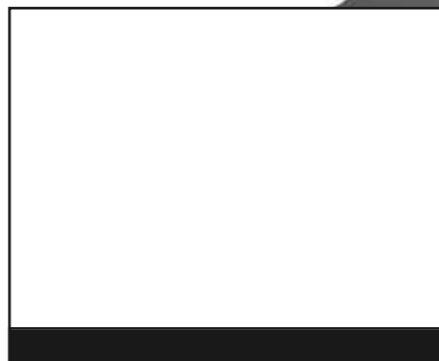
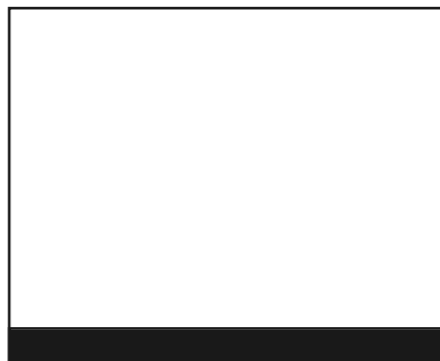
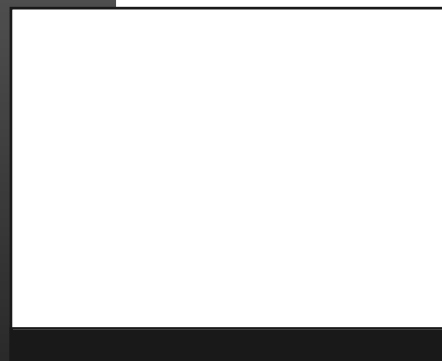
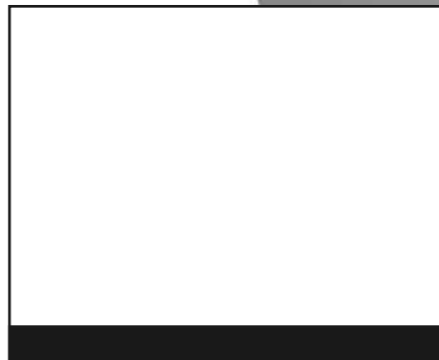
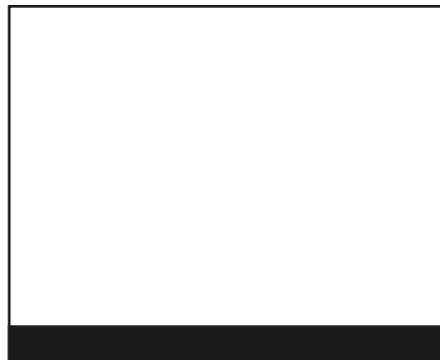
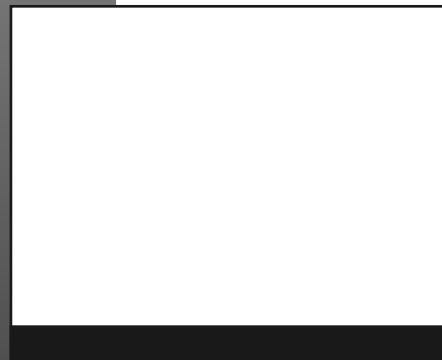
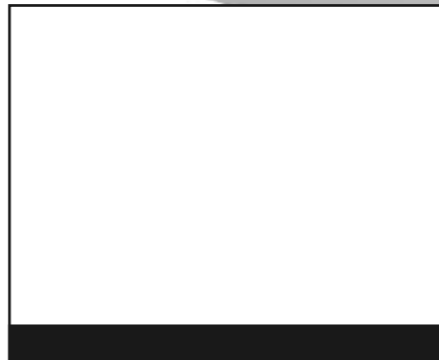
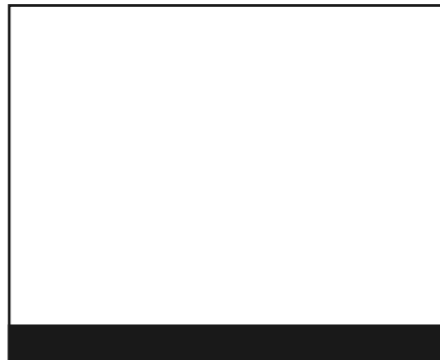
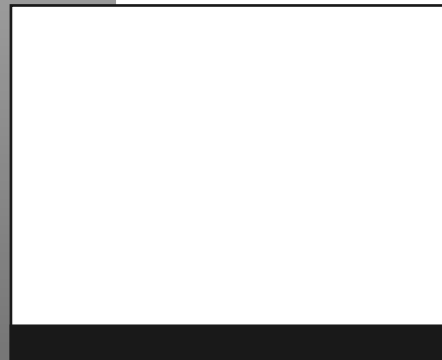

FABRICA Y DISTRIBUYE
MAKES AND DISTRIBUTES

e-mail: info@alycosrl.com.ar • web site: www.alycosrl.com.ar